

# OPERATOR'S MANUAL

**Haulotte**   
GROUP

**BILJAX**

---

# 45XA

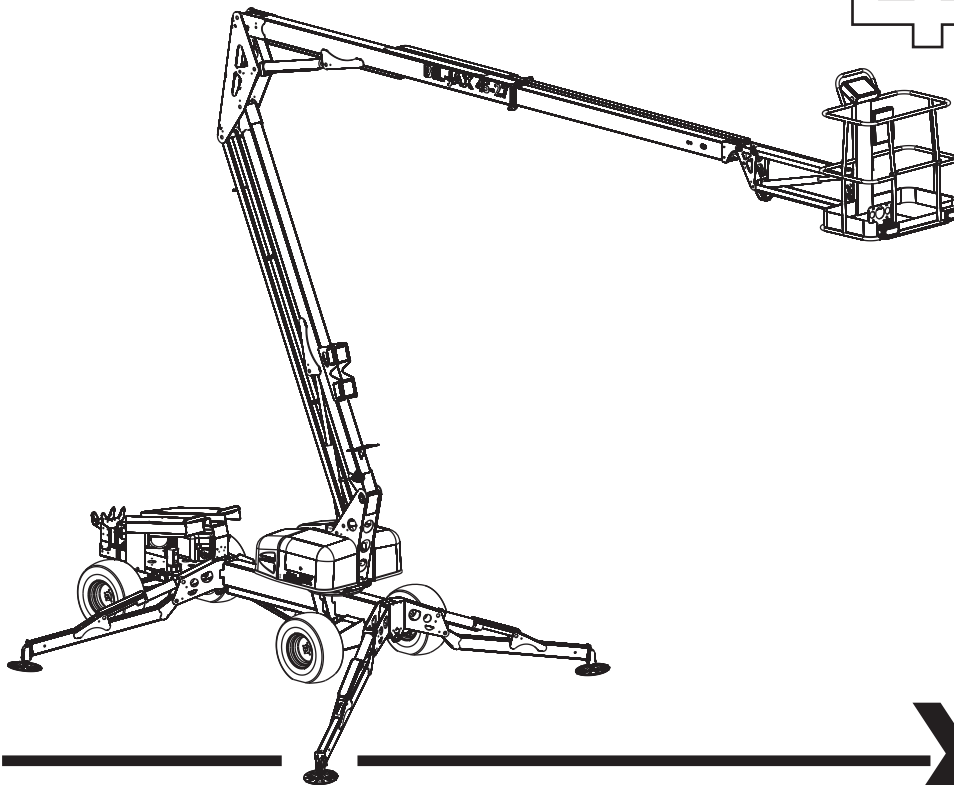

---

**X-BOOM**  
AERIAL WORK PLATFORMS™

---

## **SELF-PROPELLED AERIAL WORK PLATFORM**

This equipment is designed and manufactured in compliance with the duties, responsibilities and standards set forth in the ANSI, CE, CSA and/or AS standards in effect at the time of manufacture.

**This equipment will meet or exceed applicable ANSI, CE, CSA and/or AS codes and standards when operated in accordance with manufacturer's recommendations.**

It is the responsibility of the user to follow all regional codes and regulations that govern the safe operation of this equipment.

**Obtain, read and obey all safety precautions before performing maintenance or repairs or attempting to operate this equipment.** This includes all manufacturer recommendations as well as those directives set forth by government and local authorities.

To ensure proper and safe use of this equipment, it is strongly recommended that only trained and authorized personnel attempt to operate and maintain the boom lift.

This manual shall be considered a permanent and necessary component of the machine and shall be kept with the boom lift at all times.

Owners and Lessors should complete a full inspection of all components and perform a test of all functions, including brake functions, before commissioning or reselling the machine. Repair or replace all damaged or malfunctioning components.

---

BilJax, Inc. is dedicated to the continuous improvement of this and all BilJax products. Therefore, equipment information is subject to change without notice. Direct any questions or concerns regarding errors or discrepancies in this manual to the BilJax Service Department.

---

**Copyright © BilJax, Inc. 2009. All Rights Reserved.**

"BilJax" and "X-Boom" are trademarks of BilJax, Inc., a member of the Haulotte Group. Contact BilJax for replacement manuals.

**Haulotte**   
G R O U P

**BILJAX**

125 Taylor Parkway  
Archbold, Ohio 43502  
Phone (800) 537-0540  
(419) 445-8915  
Fax (419) 445-0367

# TABLE OF CONTENTS

---

<b>Table of Contents</b>	<b>1</b>
<b>Illustrations</b>	<b>2</b>
<b>Tables</b>	<b>2</b>
<b>1 Safety</b>	<b>3</b>
Legend: Safety Advisories	4
Before Operation	5
During Operation	5
Maintenance Safety	7
Damaged Equipment Policy	8
<b>2 Before Operation</b>	<b>9</b>
Daily Service Checks	10
Weekly Service Checks	12
Monthly Service Checks	12
Workplace Inspection	13
<b>3 Operation</b>	<b>15</b>
Ground Control Station	16
Platform Control Station	18
Platform Controls Joystick	20
Operation: Set Up	21
Operation: Ground Controls	22
Operation: Platform Controls	23
Operation: Drive Functions	23
Manual Boom Operation	24
Battery Recharge	26
Boom Lift Transport	27
<b>4 Troubleshooting</b>	<b>29</b>
Troubleshooting	30
Error Code Definitions	31
<b>5 Replacement Decals</b>	<b>35</b>
<b>6 Specifications</b>	<b>41</b>
<b>7 Equipment Options</b>	<b>45</b>
Material Lifting Hook	46
Platform Rotator	47

# LIST OF ILLUSTRATIONS

---

Figure 2-1	Outrigger Position Switches	9
Figure 2-2	Hydraulic Reservoir	10
Figure 2-3	Wheel Nut Tightening Sequence	10
Figure 3-1	Ground Control Panel	16
Figure 3-2	Platform Control Panel	18
Figure 3-3	Platform Controls Joystick	20
Figure 3-4	Outrigger Controls	21
Figure 3-5	Boom Travel Latch	21
Figure 3-6	Manual Brake Release	21
Figure 3-7	Hand Pump and Controls for Manual Operation	24
Figure 3-8	Manual Lowering Valve	25
Figure 3-9	Battery Charger Faceplate	26
Figure 3-10	Boom Lift and Transport Instructions	27
Figure 5-1	Decal Placements	37
Figure 5-2	Decal Placements – CE	39
Figure 6-1	Range of Motion	43
Figure 7-1	Material Lifting Hook Configuration	46
Figure 7-2	Material Lifting Hook Installation	46
Figure 7-3	Manual Platform Rotator	47

# LIST OF TABLES

---

Table 1-1	Minimum Safe Approach Distances	4
Table 3-1	Charger Fault Codes	26
Table 4-1	Troubleshooting Steps	30
Table 4-2	Error Code Definitions	31
Table 5-1	Decal Descriptions	36
Table 5-2	Decal Descriptions – CE	38

# 1 SAFETY

---

Proper training is required for the safe operation of any mechanical device. Failure to follow all instructions and safety precautions in this manual and attached to the lift will result in death or personal injury.

## **Prior to Operation:**

- Read, understand and obey all instructions and safety precautions in this manual and attached to the lift.
- Read, understand and obey all applicable government regulations.
- Become familiar with the proper use of all controls.
- Inexperienced users should receive instruction before attempting to operate or maintain the machine.

The use of intelligence and common sense is the best practice when following any safety policy.

## LEGEND: SAFETY ADVISORIES

The following safety advisories are used throughout this manual to indicate specific hazards when operating or maintaining the machine. Read, understand and obey all safety advisories to prevent improper service, damage to equipment, personal injury or death.

### **DANGER** \_\_\_\_\_

**Warns of operation near electrical power sources that could lead to personal injury or death.**

---

### **WARNING** \_\_\_\_\_

**Describes conditions or practices that could lead to personal injury or death.**

---

### **CAUTION** \_\_\_\_\_

**Contains information important in the prevention of errors that could damage machine or components.**

---

**NOTE: Contains additional information important for performing a procedure.**

## BEFORE OPERATION

Ensure the following general safety precautions are followed before operating the Aerial Work Platform:

ALWAYS inspect the usage area for potential hazards, such as unstable or unlevel surfaces, overhead obstructions and electrically charged wires or conductors. ALWAYS watch for moving vehicles in the operating area.

ALWAYS conduct a thorough inspection of the machine before operation. Check for damaged or worn parts, hydraulic leaks, damaged wiring, loose wiring conductors, damaged outriggers, low tire pressure, uneven tire wear or tire damage. Check for any improperly operating components. NEVER operate equipment if any damage is observed or suspected. Repair damaged or malfunctioning equipment before operation.

ALWAYS wear proper clothing and footgear. Wear protective equipment as required by government regulations. Keep loose clothing, jewelry, gloves and hair away from moving parts.

ALWAYS wear a safety harness and energy-absorbing lanyard.

ALWAYS inspect platform floor and outrigger footpads for mud, grease, debris or other foreign material. ALWAYS remove any such material from the equipment before operation.

ALWAYS tag any part of the equipment known or suspected to be damaged or malfunctioning. ALWAYS remove a malfunctioning, damaged or defective machine from service. NEVER operate a machine that has any known or suspected defect.

ALWAYS comply with the instructions found in Safety and/or Service Bulletins distributed by the manufacturer. Bulletins may contain critical procedures that supersede the information contained in manuals.

NEVER operate this equipment while under the influence of drugs or alcohol, while taking prescription medications that may leave the operator drowsy or prone to dizziness, or while feeling ill.

NEVER modify the equipment in any way that would affect its original design or operation.

NEVER deface, modify or obscure any decals or markings on equipment.

NEVER operate the equipment in any way for which it is not intended.

## DURING OPERATION

Ensure the following general safety precautions are followed while operating the Aerial Work Platform:

ALWAYS position lift away from power lines to ensure that no part of the lift can accidentally reach into an unsafe area. This includes full extension of the boom through 700° rotation.



**This machine is NOT insulated for use near electrical power lines and DOES NOT provide protection from contact with or close proximity to any electrically charged conductor. Operator must maintain safe clearances at all times (3.05 meters minimum) and must always allow for platform movement due to gusty winds. Always contact power company before working near power lines. Assume every power line is live. Power lines can be blown by the wind. Refer to Table 1-1 for minimum safe approach distances between the machine and electrical power lines.**

Voltage Range (Phase to Phase)	Minimum Safe Approach Distance	
	(Feet)	(Meters)
0 to 300V	Avoid Contact	
Over 300V to 50KV	10	3.05
Over 50KV to 200KV	15	4.60
Over 200KV to 350KV	20	6.10
Over 350KV to 500KV	25	7.62
Over 500KV to 750KV	35	10.67
Over 750KV to 1000KV	45	13.72

**Table 1-1. Minimum Safe Approach Distances**

ALWAYS keep away from a machine that is exposed to energized power lines. If the machine contacts energized power lines, NEVER touch or operate the machine until power lines are shut off.

ALWAYS operate only on a firm and level surface. NEVER operate on surfaces that do not support the equipment with its rated load capacity or on surfaces that do not support force exerted by the outriggers during boom operation. Operate only on surfaces that can support a pressure of 1.8 kg/cm<sup>2</sup> (25 psi) to ensure safe operation.

ALWAYS keep personnel away from potential pinch and shear points and from potential crush hazards as indicated by decals attached to the machine.

ALWAYS keep the safety bar lowered unless personnel are entering or exiting the work platform.

ALWAYS keep personnel and obstructions clear of the machine when repositioning boom or basket.

ALWAYS cordon the area surrounding the outriggers to keep personnel, vehicles and moving equipment away from the machine while in use.

ALWAYS stay clear of overhead obstructions, including wires and cables.

ALWAYS engage boom travel latches before towing trailer.

ALWAYS exercise caution when rotating the boom from the ground control station. ALWAYS watch for personnel inside the radius of the turntable and boom arm when rotating the boom lift from the ground or platform controls.

ALWAYS remove personnel from the boom lift before attempting to free an elevated platform that has become caught or snagged on an adjacent structure or obstacle.

NEVER operate the machine on any surface other than firm and level ground. NEVER operate the machine from a position on truckbeds, trailers, floating vessels or scaffolding without written approval from the manufacturer.

NEVER operate lift functions on slopes exceeding 12.5°.

NEVER allow electrode contact with any part of the machine while welding from the platform. NEVER use the machine as a ground for welding.

NEVER operate without the outriggers fully extended or when the machine is not level.

NEVER position an elevated platform against another object to steady the platform

NEVER override or bypass the manufacturer's safety devices.

NEVER attach a safety harness to an adjacent structure, pole, or to nearby equipment while working from the boom platform.

NEVER raise the outriggers while boom is raised or extended.

NEVER sit, stand or climb on cage bars. ALWAYS keep both feet firmly on the work cage floor when working from an elevated platform.

NEVER attempt to increase the working height with boxes, ladders, stools or any other materials.

NEVER operate this equipment when exposed to high winds, thunderstorms, ice or any weather conditions that would compromise operator safety.

NEVER operate boom lift in conditions where wind speeds exceed 12.5 m/sec (45 km/h or 28 mph). High winds may affect stability and boom operation.

NEVER allow ropes, electric cords, hoses or other equipment to become entangled in the machine while raising or lowering platform.

NEVER exceed the load limits set by the manufacturer. Use only the Material Lifting Hook, supplied as an option and manufactured by BilJax, when lifting materials. Safely stow all tools and equipment.

NEVER exceed load ratings by transferring loads to the lift at elevated heights.

NEVER use the platform to lift a load that exceeds the platform dimensions. NEVER lift a load in such a way that the center of gravity is higher than the top guardrail of the platform.

NEVER modify the platform or carry materials that would increase the surface area of the platform. Increasing the area exposed to the wind may decrease machine stability. NEVER attach overhanging loads when raising or lowering the platform.

NEVER use the boom or platform to push or pull or to lift any part of the machine.

NEVER use the boom or platform to place a load against any structure, materials or equipment.

NEVER climb on the boom.

NEVER leave an elevated platform unattended.

NEVER leave the keys in the boom lift while unattended or not in use.

### **Drive Safety**

ALWAYS maintain an awareness of limited sight and blind spots when operating drive functions.

ALWAYS limit travel speed according to surface conditions, slope, location of personnel and obstructions and any other factors which may result in collision.

NEVER operate drive functions on slopes exceeding 20°.

NEVER engage in stunt driving, horseplay or any other behavior considered unsafe according to employer, job site and/or government regulations.

NEVER operate the internal combustion engine in an area that is not properly ventilated.

NEVER fuel the internal combustion engine while smoking, or while near spark or open flame.



## MAINTENANCE SAFETY

Ensure the following general safety precautions are followed while performing maintenance on the Aerial Work Platform:

### General Maintenance

ALWAYS perform maintenance procedures according to manufacturer's guidelines. NEVER disregard or bypass proper maintenance procedures.

ALWAYS inspect hydraulic system to ensure that all lines, connectors and fittings are properly fastened and in good condition.

ALWAYS turn the key switch OFF and remove key before performing maintenance.

ALWAYS perform maintenance with the boom and platform in a fully lowered, stowed position, when possible. ALWAYS secure the boom before performing maintenance on hydraulic cylinders.

ALWAYS disconnect power to the hydraulic pump drive motor before making electrical checks to the hydraulic valves.

ALWAYS keep all mechanical parts properly adjusted and lubricated according to maintenance schedule and manufacturer's specifications.

ALWAYS perform a function check of operating controls before each use and after repairs have been made.

ALWAYS locate and protect against possible pinch points before performing any maintenance or repairs.

ALWAYS use only manufacturer-approved parts to repair or maintain equipment. If any portion of this equipment is rebuilt or repaired, retesting is required in accordance with factory instructions.

ALWAYS maintain a safe distance while testing the hydraulic components. ALWAYS relieve hydraulic pressure before loosening or removing hydraulic components. NEVER test or operate the hydraulic components while personnel are near the equipment.

NEVER allow water or foreign particles into the DC electric motor housing. Inclusion of water or foreign particles may cause serious damage to the motor. If the motor becomes wet, consult an authorized BilJax service technician for proper drying instructions.

NEVER add unauthorized fluids to the hydraulic system or battery. NEVER mix hydraulic oils. Consult manufacturer specifications. Refer to

Section 4 for hydraulic system maintenance procedures.

NEVER exceed the manufacturer's recommended relief valve settings.

NEVER touch or allow metal tools to contact any components that are sensitive to static discharge. ALWAYS use static discharge prevention mats and grounding devices when handling electronic components.

NEVER adjust, repair, replace or bypass any hydraulic or electrical control or safety device. These include, but are not limited to, hydraulic load control and flow control valves, solenoid valves and limit switches. ALWAYS consult an authorized BilJax technician if repairs are necessary.

NEVER modify, alter or change the equipment without first consulting an authorized BilJax technician, and NEVER in any way that would affect its original design or operation.

### Battery Maintenance

Ensure the following general safety precautions are followed when performing battery maintenance on the Aerial Work Platform.

ALWAYS wear safety glasses when working with or near batteries.

ALWAYS check the battery fluid level daily.

ALWAYS avoid contact with battery acid. Battery acid causes serious burns and should be kept away from skin or eyes. If contact occurs, flush with water and consult a physician immediately.

ALWAYS disconnect ground cable first when removing battery.

ALWAYS connect ground cable last when installing battery.

ALWAYS charge batteries in open, well-ventilated areas.

ALWAYS replace batteries using only parts recommended by manufacturer. ALWAYS use only batteries with sealed caps over cells.

NEVER smoke while servicing batteries.

NEVER charge batteries near spark or open flame.

NEVER allow batteries to overcharge and boil.

NEVER short across battery posts to check for current. NEVER break a live circuit at the battery.

NEVER disconnect battery from charger while charger is connected to a live power source.

NEVER jumpstart other vehicles using the boom lift batteries.

## **DAMAGED EQUIPMENT POLICY**

### **Safety Statement**

At BilJax, we are dedicated to the safety of all users of our products. All BilJax lifts are designed, manufactured and tested to comply with current applicable ANSI and/or CE codes and regulations.

### **Damage Policy**

There may be occasions when a BilJax lift is involved in an incident that results in structural damage to the lift. Such damage can seriously compromise the ability of the lift to perform in a safe manner. Therefore, whenever a BilJax lift is damaged structurally or when there is suspected internal damage to the structure, BilJax may require that the lift be returned to our facility for reconditioning. For any questions concerning structural damage or the Damaged Equipment Policy, please contact an authorized BilJax representative or your regional BilJax dealer

### **Damage Repair Notice**

There may be occasions when a BilJax lift is involved in an accident resulting in damage to non-structural components. When such damage occurs and repairs are made by the owner or area distributor, please notify BilJax of these non-maintenance repairs and request a repair form to be filled out and returned to BilJax.

# 2 BEFORE OPERATION

---

Inspections of the aerial work platform and the intended work area should be performed daily before operation. Failure to inspect machine and work area may result in death or personal injury.

## **Prior to Operation:**

- ❑ Conduct a pre-operation inspection of the aerial work platform by performing all daily service checks as explained in this manual, as well as all weekly and/or monthly service checks, if applicable.
- ❑ Inspect the work area.

A comprehensive schedule of service checks and maintenance can be found in the Parts and Service Manual. Annual service checks and structural inspections should be performed only by personnel trained and certified in accordance with applicable government regulations.

## DAILY SERVICE CHECKS

The following maintenance procedures should be performed daily or before each operation.

### Verify that all decals are correctly applied and in plain view.

- ❑ Refer to Section 5 for decal locations.

### Verify that all controls and indicators at ground and platform control stations operate properly.

- ❑ Lower outriggers to level the boom lift.
- ❑ Raise and extend all booms.
- ❑ Press emergency STOP button.
- ❑ Verify that booms remain elevated and do not drift.
- ❑ Pull out STOP button and lower the booms.
- ❑ If either control station is unresponsive, refer to Table 4-1 for troubleshooting procedures.
- ❑ If display panel displays an error code, refer to Table 4-2 for error code definitions.

### Verify correct tire inflation.

- ❑ Inflate tires to 20 psi (140 kPa).

### Inspect tires for damage or loose or missing lug nuts.

- ❑ Repair or replace as necessary.\*

### Inspect structural components and platform for obvious damage or debris.

- ❑ Repair or replace as necessary.

### Inspect machine for missing, loose or damaged fasteners, including pins and bolts.

### Check engine oil level.

- ❑ Add oil as needed.
- ❑ Manufacturer recommends engine oil type 5W-30.

### Check engine fuel level.

- ❑ Add fuel as needed.

### Verify that boom down limit switches operate correctly.

- ❑ Down limit switches are actuated when the boom is in a fully lowered, stowed position. Limit switches must be operational to raise or lower outriggers.
- ❑ If outrigger controls are unresponsive when boom is fully lowered and stowed, inspect down limit switches for loose mounting or visible damage.
- ❑ Repair or replace as needed.

### Verify that outrigger safety interlocks operate correctly.

- ❑ Begin with the outriggers fully extended and the boom lift level. Raise one outrigger until the footpad is not in contact with the ground.
- ❑ Verify that boom functions are unresponsive when one outrigger is raised.
- ❑ Repeat this procedure for each outrigger.
- ❑ Raise all outriggers until the footpads are not in contact with the ground. Verify that all outrigger status LEDs on the ground control panel are unlit.
- ❑ Lower one outrigger until the footpad makes contact with the ground and the outrigger begins lifting the trailer.
- ❑ If the LED is lit before the footpad makes contact with the ground or if the LED remains unlit after the weight is transferred to the outrigger, the position switch or wiring is faulty.
- ❑ Repeat this procedure for each outrigger.
- ❑ Repair or replace as needed. Refer to Figure 2-1.

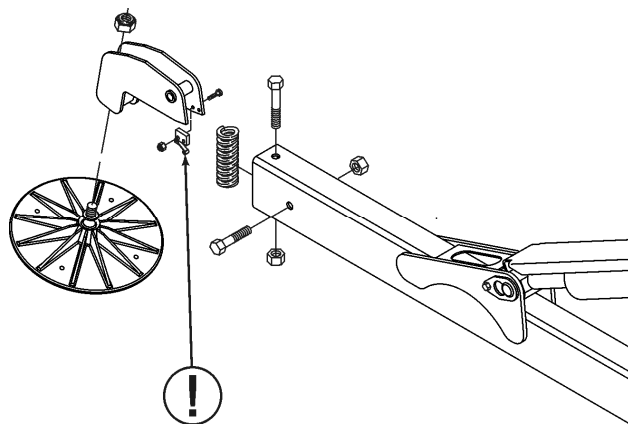

Figure 2-1. Outrigger Position Switches

\* Repair and replacement of machine components should be performed only by trained and certified personnel in accordance with government regulations and manufacturer recommendations.

**Inspect hydraulic system and fluid levels.**

- ❑ Check all hydraulic hoses and fittings for leaks and damage. Tighten or replace as necessary to prevent hydraulic oil or pressure loss.
- ❑ The hydraulic oil level should be checked with the booms down, all outriggers raised and the wheels on a level surface.
- ❑ Hydraulic oil level should be visible in, but not above, the sight gauge.
- ❑ If the hydraulic oil level is not visible to at least half way up the sight gauge (Figure 2-2), add clean hydraulic fluid as necessary while all booms and outriggers are fully retracted and stowed. Pour slowly to avoid creating air pockets in the reservoir. Do not fill above sight gauge. Overfilling the hydraulic reservoir may cause damage to hydraulic lines and may result in equipment malfunction.

**CAUTION**

**Do not mix hydraulic oils. Do not add any fluid to the hydraulic system that is not expressly recommended by the manufacturer. Adding unauthorized fluids to the hydraulic system may cause damage to equipment**

- ❑ The hydraulic reservoir is originally filled with Dexron III/Mercon ATF with a viscosity rating of 175.
- ❑ Manufacturer recommends a higher viscosity hydraulic oil when operating equipment routinely in extreme climates.

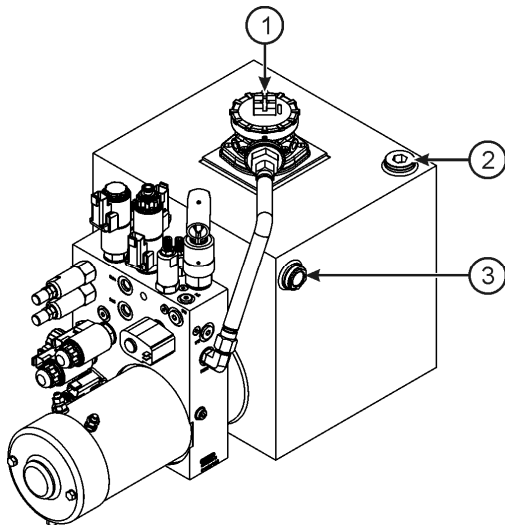

1. Filter Element
2. Fill Port
3. Sight Gauge

**Figure 2-2. Hydraulic Reservoir**

## WEEKLY SERVICE CHECKS

Perform the following service checks at least once each week in addition to all recommended daily service checks:

### Check Battery electrolyte level.

- ❑ If battery electrolyte level is low, add enough distilled water to bring the electrolyte level to the top of the plates.
- ❑ If batteries are fully charged, raise electrolyte level to full mark in each cell.

### Inspect all electrical wiring.

- ❑ Check for cuts, loose terminals, broken wires, chaffing and corrosion.
- ❑ Repair all damage, remove corrosion and seal exposed connections.

### Inspect transport hitch components for damage.

### Inspect boom lift for missing, loose or damaged hardware.

- ❑ Repair or replace as necessary.

### Inspect all hydraulic system components including pump and motor and cylinders for damage, leaks, loss of pressure or speed, and unusual noise or vibration.

- ❑ Repair or replace as necessary.

## MONTHLY SERVICE CHECKS

Perform the following service checks at least once each month in addition to all recommended daily service checks:

### Clean all battery terminals.

### Check battery for loose connections or damaged wires.

### Verify proper operation of manual lowering valves and hand pump

- ❑ Refer to Section 3 for manual boom operating procedures.

### Lubricate all compartment hinges and latches, slew ring and mating gear.

- ❑ Use NLGI Grade 2 multi-purpose grease.

### Check wheel nut torque.

- ❑ Refer to Figure 2-3 for correct wheel nut tightening sequence.
- ❑ Evenly tighten wheel nuts to 34 N\*m in the tightening sequence shown.
- ❑ Repeat sequence, tightening wheel nuts to 81 N\*m and to 136 N\*m.

**NOTE: Follow this procedure each time the wheel is removed and reinstalled.**

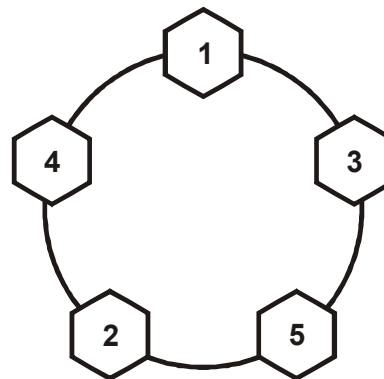

Figure 2-3. Wheel Nut Tightening Sequence

## WORKPLACE INSPECTION

Before operating the machine, be aware of and avoid the following:

- Drop-offs
- Holes
- Floor obstructions or debris
- Sloped surfaces outside the capabilities of the boom lift
- Unstable or slippery surfaces
- Surfaces that will not support the load forces imposed by the machine or outriggers
- Overhead obstructions and high voltage conductors
- Sinkholes and untamped earth fills
- Personnel
- Unsafe weather conditions
- Other vehicles and equipment
- Other unsafe conditions





# 3 OPERATION

---

The Model 45XA Aerial Work Platform is equipped with multiple operator control stations. Operators can use boom and outrigger functions from both the platform and ground control panels. Drive functions are found on the platform control panel.

Before attempting boom lift operation, Operators should:

- ❑ Attend a training program as required by government regulations.
- ❑ Obtain, read and obey all safety precautions as indicated by manufacturer's recommendations and all federal, state and local regulations.
- ❑ Become familiar with the location and use of all controls.
- ❑ Verify that there are no overhead obstructions or live power sources in the work area that could interfere with the safe operation of the boom lift.
- ❑ Position the boom lift on a firm and level surface.
- ❑ Conduct a Pre-Operation inspection by performing all recommended Daily Service Checks. Refer to Section 2.

## GROUND CONTROL STATION

The ground control station is used to operate outriggers and control boom motion. To access the ground control station, open the control panel access cover found on the turntable. Turn the key switch to the ground controls setting.

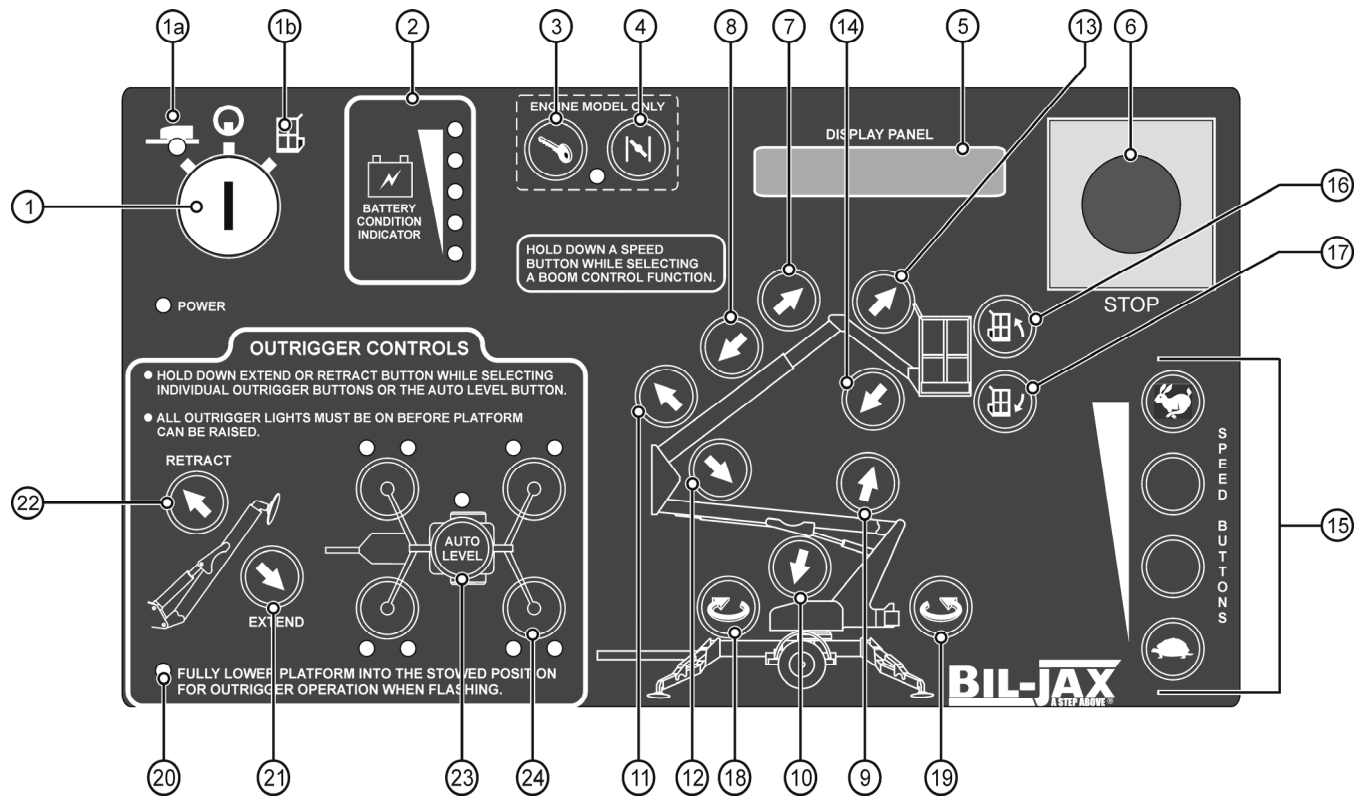

Figure 3-1. Ground Control Panel

- |                                |                                      |
|--------------------------------|--------------------------------------|
| 1. Key Switch                  | 12. Upper Boom Down                  |
| 1a. Ground Controls Position   | 13. Jib Raise                        |
| 1b. Platform Controls Position | 14. Jib Down                         |
| 2. Battery Condition Indicator | 15. Speed Buttons                    |
| 3. Engine Start                | 16. Platform Tilt – Up               |
| 4. Engine Choke                | 17. Platform Tilt – Down             |
| 5. Display Panel               | 18. Boom Rotation – Clockwise        |
| 6. Emergency Stop              | 19. Boom Rotation – Counterclockwise |
| 7. Boom Extend                 | 20. Outrigger Status Indicator LED   |
| 8. Boom Retract                | 21. Outrigger Extend                 |
| 9. Lower Boom Raise            | 22. Outrigger Retract                |
| 10. Lower Boom Down            | 23. Auto Level                       |
| 11. Upper Boom Raise           | 24. Outrigger Button                 |

The ground control station includes the following controls and Indicators. Refer to Figure 3-1 for control locations.

### **1. Key Switch**

Turning the key switch to the PLATFORM (1A) icon selects operation from the platform. Turning the key switch to the GROUND (1B) icon selects operation from the ground control panel. The center (power off) position interrupts all electric and hydraulic power operations except emergency lowering. Removing the key protects against operation by unauthorized persons. The key may be removed with the key switch in any selected position.

### **2. Battery Condition Indicator**

Indicator LEDs light up to indicate the level of charge remaining in the batteries. A lighted green LED indicates an adequate charge level. Lighted yellow LEDs indicate the need for charging soon. A lighted red LED warns that the battery charge level is low; boom operations should be halted until the batteries are recharged.

### **3-4. Engine Start and Choke**

Start a cold engine by pressing the Engine START button while pressing and holding the CHOKE button. To start/restart a warm engine, press the START button only.

### **5. Display Panel**

The DISPLAY PANEL is a lighted text window that displays the present operating status or an existing error condition when the key switch is on.

### **6. Emergency Stop Button**

When pushed in, the emergency STOP button disconnects electrical power to the ground and platform control stations. The emergency STOP pushbutton should only be pressed to immediately stop all boom motion. To resume control, pull out the emergency STOP button.

### **7-8. Boom Extend/Retract Buttons**

Pressing and holding a desired SPEED button and the BOOM EXTEND button at the same time extends the telescopic boom. Pressing and holding a desired SPEED button and the BOOM RETRACT button at the same time retracts the boom. Boom motion

continues until the buttons are released or until the boom reaches a hard stop or a safe travel limit.

### **9-14. Boom Raise/Down Buttons**

Pressing and holding a desired SPEED button and the UPPER/LOWER/JIB BOOM RAISE button at the same time will raise the chosen boom. Pressing a desired SPEED button and the UPPER/LOWER/JIB BOOM DOWN button at the same time will lower the chosen boom. Boom motion continues until the buttons are released or until the boom reaches a hard stop or a safe travel limit.

### **15. Speed Buttons**

The SPEED buttons along the lower right side of the control panel must be pressed and held while selecting a boom function. Four speeds are available to control the positioning of the boom lift.

### **16-17. Platform Tilt Buttons**

Press and hold any SPEED button and the desired PLATFORM TILT button at the same time to level the work platform (levels the platform only, not the boom lift).

### **18-19. Boom Rotation Buttons**

Pressing and holding a desired SPEED button and the BOOM ROTATION CLOCKWISE or COUNTERCLOCKWISE button at the same time enables the boom to rotate in the direction selected. The boom will rotate through 700 degrees until the buttons are released or the stop is reached.

### **20-24. Outrigger Controls**

For automatic outrigger extension/retraction: Select EXTEND or RETRACT outrigger button and the AUTO LEVEL button at the same time. To manually extend or retract the outriggers: Select EXTEND or RETRACT outrigger button and one of the OUTRIGGER buttons at the same time. The outrigger indicator LEDs light up when the outriggers are properly deployed and the boom weight is on the outriggers. Each of the outer outrigger LEDs indicates load is on the outrigger footpad. Each of the inner outrigger LEDs, when flashing, indicate that side is low and needs to be further raised for leveling. The Auto Level LED lights up and a buzzer sounds when the boom is level.

## PLATFORM CONTROL STATION

The platform control station is used to control boom motion. To access the platform control station, turn the key switch at the ground control station to the platform controls setting and enter the work cage.

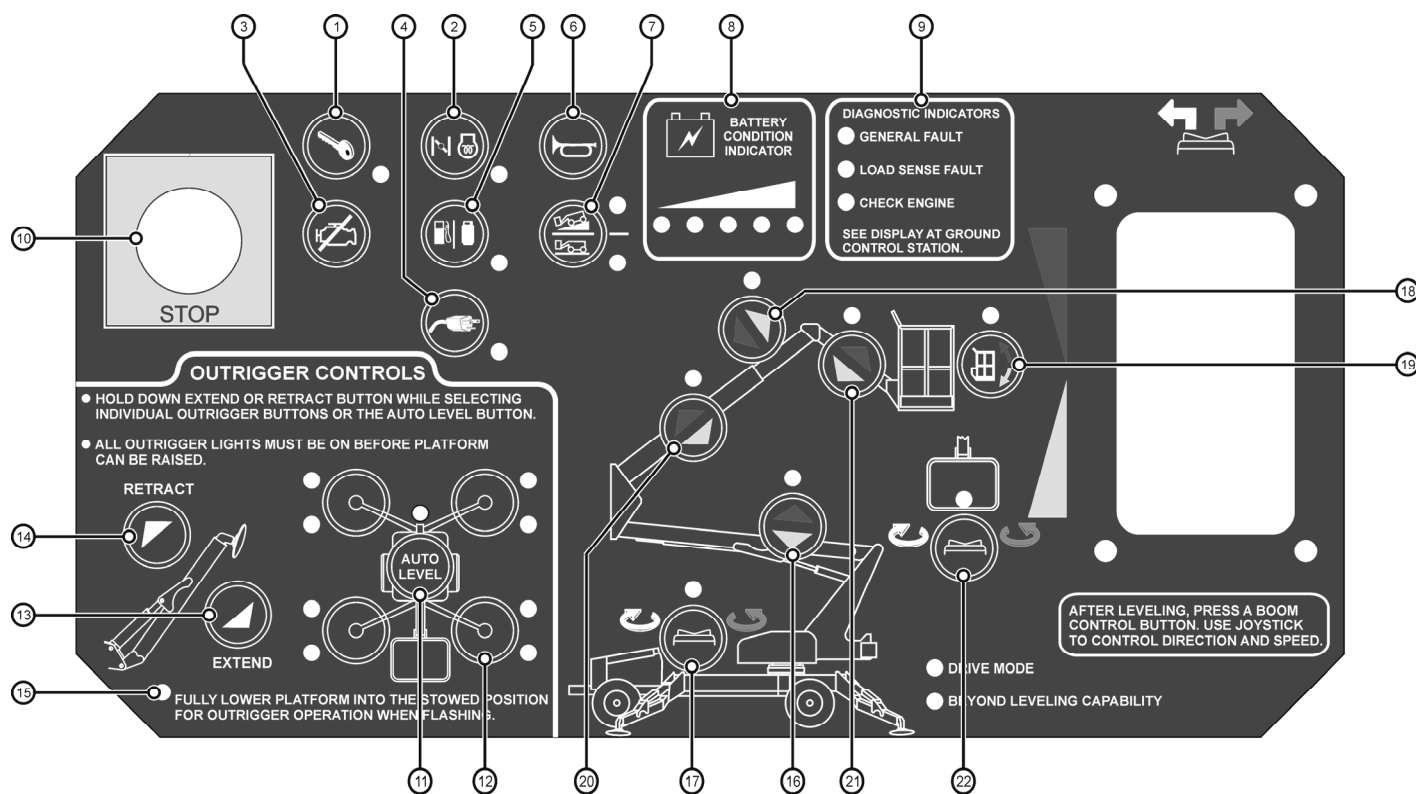

Figure 3-2. Platform Control Panel

- |                                |                                    |
|--------------------------------|------------------------------------|
| 1. Engine Start                | 12. Outrigger Buttons              |
| 2. Engine Choke                | 13. Outrigger Extend               |
| 3. Engine Stop                 | 14. Outrigger Retract              |
| 4. Generator On/Off            | 15. Outrigger Condition Status LED |
| 5. Fuel Toggle                 | 16. Lower Boom Raise/Down          |
| 6. Horn                        | 17. Boom Rotation                  |
| 7. Drive Speed Selector        | 18. Boom Extend/Retract            |
| 8. Battery Condition Indicator | 19. Platform Tilt                  |
| 9. Diagnostic Indicators       | 20. Upper Boom Raise/Down          |
| 10. Emergency Stop             | 21. Jib Raise/Down                 |
| 11. Auto Level                 | 22. Jib Rotation (Option)          |

The platform control station includes the following controls and Indicators. Refer to Figure 3-2 for control locations.

### **1-2. Engine Start and Choke**

Start a cold engine by pressing the CHOKE button (2), then press the engine START button (1) to start the engine. To start/restart a warm engine, press the START button only.

### **3. Engine Stop**

Press to stop the engine. If charged, batteries will still provide power to the lift.

### **4. Generator On/Off**

Press GENERATOR ON/OFF button to activate generator. Generator provides power to battery charger and to GFI outlets found adjacent to the ground and platform control stations.

### **5. Fuel Toggle**

Press FUEL TOGGLE button to change between fuel types. Option is not currently available on self-propelled machines.

### **6. Horn**

Press to sound the horn. Use the horn button to warn personnel in the area of a falling object hazard, impending boom motions or the need for assistance.

### **7. Drive Speed Selector**

Press DRIVE SPEED SELECTOR to switch between low speed/high torque and high speed/low torque settings. The low speed/high torque setting is recommended when operating on inclines.

### **8. Battery Condition Indicator**

Indicator LEDs light up to indicate the level of charge remaining in the batteries. A lighted green LED indicates a good charge level. Lighted yellow LEDs indicate the need for charging soon. A lighted red LED warns that the battery charge level is low; boom operations should be halted until the batteries are recharged.

### **9. Diagnostic Indicators**

Indicator LEDs warn of machine or engine issues. Refer to the display panel on the ground control panel and the troubleshooting section of this manual for fault code explanations.

### **10. Emergency Stop**

When pushed in, the emergency STOP button disconnects electrical power to the ground and platform control stations. The emergency STOP pushbutton should only be pressed to immediately stop all boom motion. To resume control, pull out the emergency STOP button.

### **11-15. Outrigger Controls**

Outrigger controls on the platform are identical to the outrigger controls on the ground control panel.

### **16. Lower Boom Raise/Down**

Press the LOWER BOOM RAISE/DOWN button until the adjacent LED indicator becomes lit. Depress the trigger on the platform controls joystick and move the joystick off center in the appropriate direction to raise and lower the boom.

### **17. Boom Rotation**

Press the BOOM ROTATION button until the adjacent LED indicator becomes lit. Press and hold the toggle button on top of the platform controls joystick, using the color-coded direction arrows to determine direction the machine will rotate. Depress the trigger on the platform controls joystick and move the joystick off center to rotate the boom.

### **18. Boom Extend/Retract**

Press the BOOM EXTEND/RETRACT button until the adjacent LED indicator becomes lit. Depress the trigger on the platform controls joystick and move the joystick off center in the appropriate direction to extend and retract the boom.

### **19. Platform Tilt**

Press the PLATFORM TILT button until the adjacent LED indicator becomes lit. Depress the trigger on the platform controls joystick and move the joystick off center in the appropriate direction to extend and retract the boom.

### **20. Upper Boom Raise/Down**

Press the UPPER BOOM RAISE/DOWN button until the adjacent LED indicator becomes lit. Depress the trigger on the platform controls joystick and move the joystick off center in the appropriate direction to raise and lower the boom.

### **21. Jib Boom Raise/Down**

Press the JIB BOOM RAISE/DOWN button until the adjacent LED indicator becomes lit. Depress the trigger on the platform controls joystick and move the joystick off center in the appropriate direction to raise and lower the boom.

### **22. Jib Rotation (Option)**

Press the JIB ROTATION button until the adjacent LED indicator becomes lit. Press and hold the toggle button on top of the platform controls joystick, using the color-coded direction arrows to determine direction the jib boom will rotate. Depress the trigger on the platform controls joystick and move the joystick off center to rotate the jib boom.

## PLATFORM CONTROLS JOYSTICK

Use the Joystick to operate drive and boom functions from the platform control station.

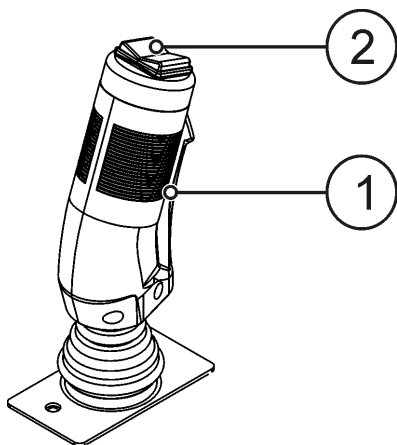

1. Joystick Trigger
2. Toggle Switch

**Figure 3-3. Platform Controls Joystick**

### **1. Joystick Trigger**

Depress the trigger after selecting a boom function and move the joystick in the desired direction to operate boom functions.

### **2. Toggle Switch**

Use the toggle switch to control direction of boom rotation and to steer the machine when using drive functions.

**OPERATION: SET UP**

- ❑ Turn the key switch on the ground controls to select the desired control station. If power does not come on, make sure both emergency STOP buttons (ground and platform) are pulled out and the main power disconnect is plugged in.
- ❑ The control microprocessor will perform self-diagnostics to test the operating system. After several seconds, the DISPLAY PANEL window will read:

**BIL – JAX  
A STEP ABOVE**

- ❑ Verify that the control status indicator LED is lit. If the control status indicator LED is not lit or is flashing, the outrigger buttons will not work. A flashing control status LED indicates that one or more of the booms is raised and needs to be stowed. Refer to Figure 3-1 and Figure 3-4.
- ❑ Extend the outriggers manually or using the AUTO LEVEL button. When the boom is leveled properly, a buzzer will sound and two LEDs at each OUTRIGGER button and the LED at the AUTO LEVEL button will be lit.

**Auto Level:** Press and hold the EXTEND and AUTO LEVEL buttons at the same time.

**Manual Level:** Extend the two outriggers closest to the trailer coupler first. Lower each pair of outriggers by pressing the EXTEND button and the two appropriate OUTRIGGER buttons at the same time.

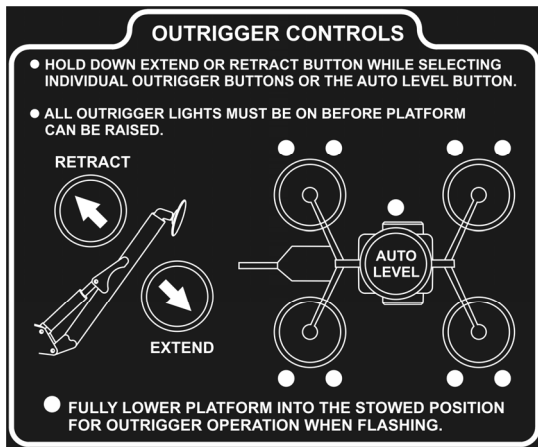

Figure 3-4. Outrigger Controls

**NOTE:** The safety interlock system prevents all boom operations if the boom is not level or if one or more outriggers are not supporting the vehicle load.

- ❑ Verify that the auto level indicator LED is lit. If the auto level indicator is not lit, the boom may not be level.
- ❑ Pull the latch release on the boom travel latches, raise the latch handle and swing the latch U-bolt down. Refer to figure 3-5.

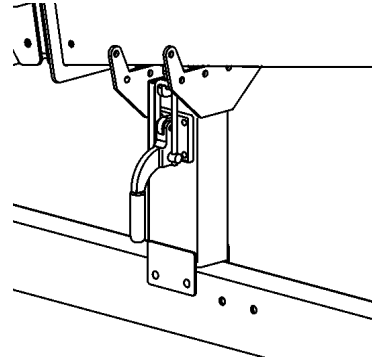

Figure 3-5. Boom Travel Latch

**Manual Brake Release**

The brake release is located in the engine compartment. Refer to Figure 3-6.

To release brakes:

- ❑ Depress the black knob.
- ❑ Pump the red knob 3-5 times to release brakes.

Activate drive function on the platform control panel to resume normal brake operation.

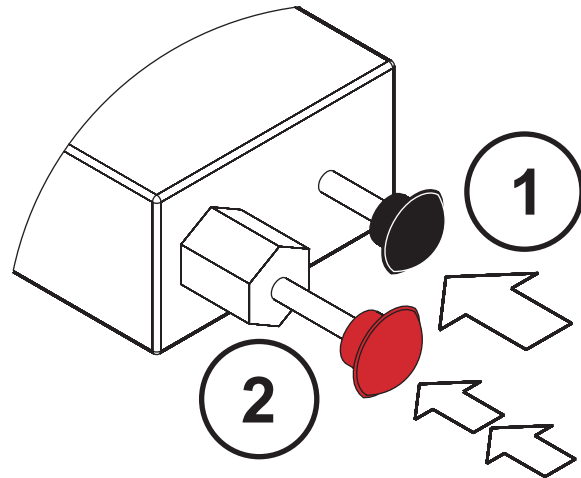

Figure 3-6. Manual Brake Release



---

## OPERATION: GROUND CONTROLS

- ❑ Turn the key switch to ground control position.
- ❑ Raise, lower, extend and rotate the boom by pressing and holding the desired SPEED and function buttons at the same time.
- ❑ When all boom lift operations are complete, fully retract the telescoping boom extension. Center boom over the boom rest and fully lower all booms until seated in the stowed position for transport. Safety switches prevent outrigger retraction until boom is completely lowered and stowed for transport.
- ❑ Engage the boom travel latches.
- ❑ Press and hold the outrigger RETRACT button and the AUTO LEVEL button until all outriggers are fully retracted to their upright positions. Inspect the area beneath lift for obstructions before retracting outriggers.
- ❑ Turn the key switch to the OFF position and remove key.

## OPERATION: PLATFORM CONTROLS

- ❑ Fully lower the boom onto the boom rest to position the platform for boarding. Turn the key switch to the platform control position.
- ❑ Raise the safety bar and enter the work platform. Put on the safety harness and attach the lanyard to the Fall Protection Attachment Point on the side of the platform support beam.

Use the platform control panel to operate the boom lift functions.

- ❑ To raise, lower, extend and rotate the boom, press the desired function button.
- ❑ An LED adjacent to the function button will become lit, indicating that the function is active.
- ❑ Depress the trigger on the platform controls joystick and move the joystick off center. Moving the joystick further off center will increase function speed. Moving the joystick toward center will decrease function speed. Returning the joystick to center and/or releasing the trigger will stop boom functions.
- ❑ Use the color-coded direction arrows to determine the direction the boom will move.
- ❑ To rotate the turntable, depress the trigger on the platform controls joystick and use the toggle switch located on top of the platform controls joystick. While pressing the toggle switch and the trigger, move the joystick off center to adjust function speed.
- ❑ Use the toggle switch and the color-coded direction arrows to determine the direction the turntable will rotate. The turntable will rotate in the desired direction regardless of which direction the joystick is moved off center.
- ❑ Should the platform become tilted out of the normal vertical axis, use the PLATFORM TILT function to adjust.
- ❑ Monitor the Battery Condition Indicator during operation and charge the batteries as necessary.
- ❑ Always fully retract, rotate and lower the boom to the stowed position before exiting the platform.

## OPERATION: DRIVE FUNCTIONS

- ❑ To drive machine, use the platform controls to raise all outriggers to a fully stowed position.
- ❑ Verify that the drive mode LED is lit.
- ❑ Depress the trigger on the platform controls joystick and move the joystick off center. Moving the joystick further off center will increase drive speed. Moving the joystick toward center will decrease drive speed. Returning the joystick to center and/or releasing the trigger will stop drive functions.
- ❑ To steer, use the toggle switch on the top of the platform controls joystick.
- ❑ Use the color-coded direction arrow to determine the direction the machine will move.

## MANUAL BOOM OPERATION

Manual retraction, rotation and lowering functions allow the aerial work platform to be moved and lowered during hydraulic power interruption or failure. In each instance, refer to Figure 3-7.

The following procedures for manual retraction, rotation and lowering require a person on the ground to operate the manual controls and hand pump.

The hydraulic hand pump is located in the pump compartment. In case of a power failure, the hand pump and selected hydraulic valve settings can be used to manually retract the Telescoping boom or rotate the boom turntable.

To begin manual retraction or rotation, turn Proportional Valve counterclockwise until it stops, and insert pump handle into the pump handle fitting.

### **Manual Retraction**

Pushing and holding the Retract button while simultaneously actuating Hand Pump will retract the extension boom section.

### **Manual Rotation**

**To rotate the turntable clockwise:** Push and hold the Rotation button and simultaneously actuate Hand Pump.

**To rotate the turntable counterclockwise:** Pull the Rotation button out and simultaneously actuate Hand Pump.

**NOTE: Return proportional valve to its original position before lowering the lift or resuming normal operation.**

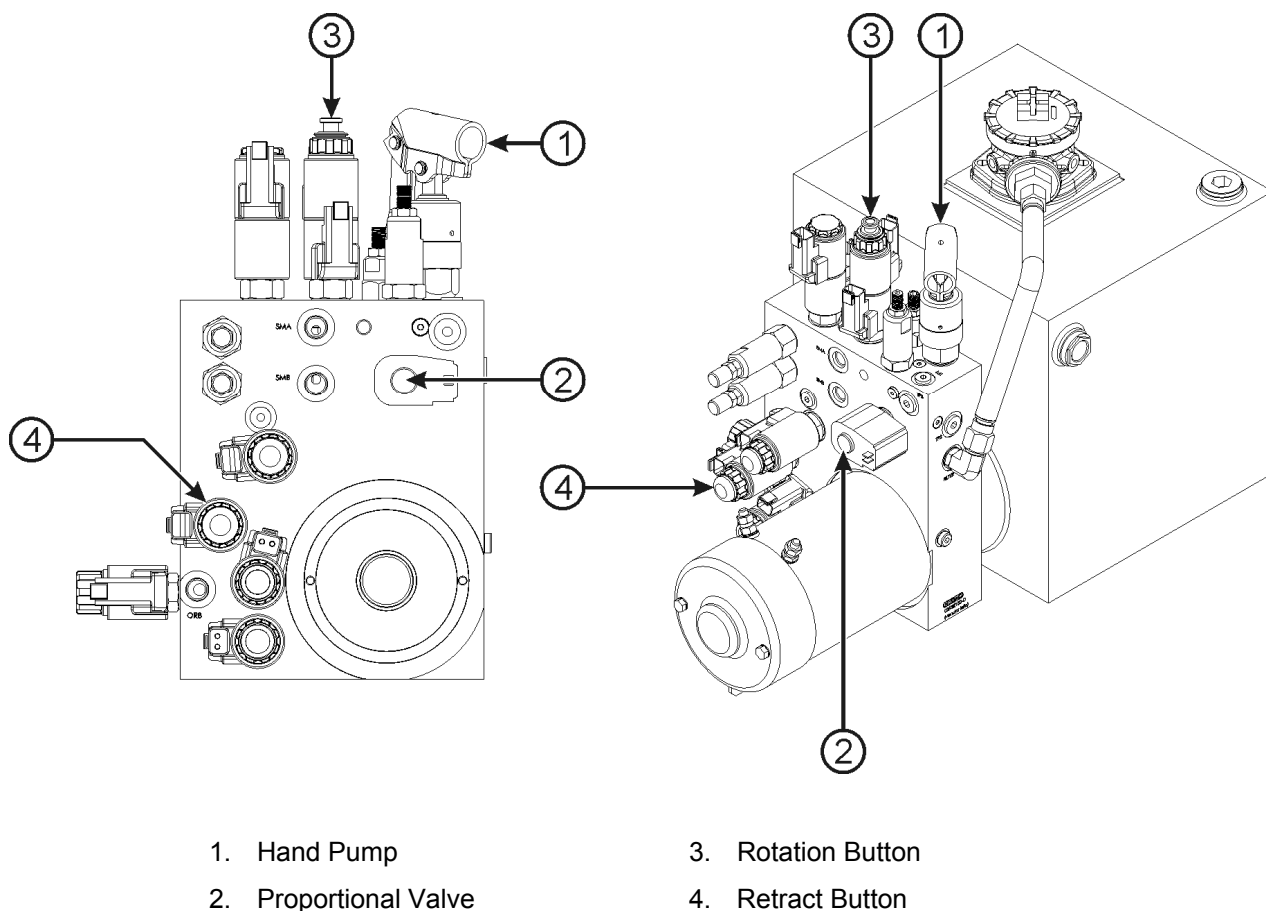

**Figure 3-7. Hand Pump and Controls for Manual Lift Operation**

### **Manual Lowering**

Each Manual Lowering Valve is equipped with a plunger, found at the base of the lift cylinder (Figure 3-8). Depress the plunger to lower the platform in case of a complete electrical power failure, a load shift, or other emergency. Continue pressing the plunger to completely lower the boom.

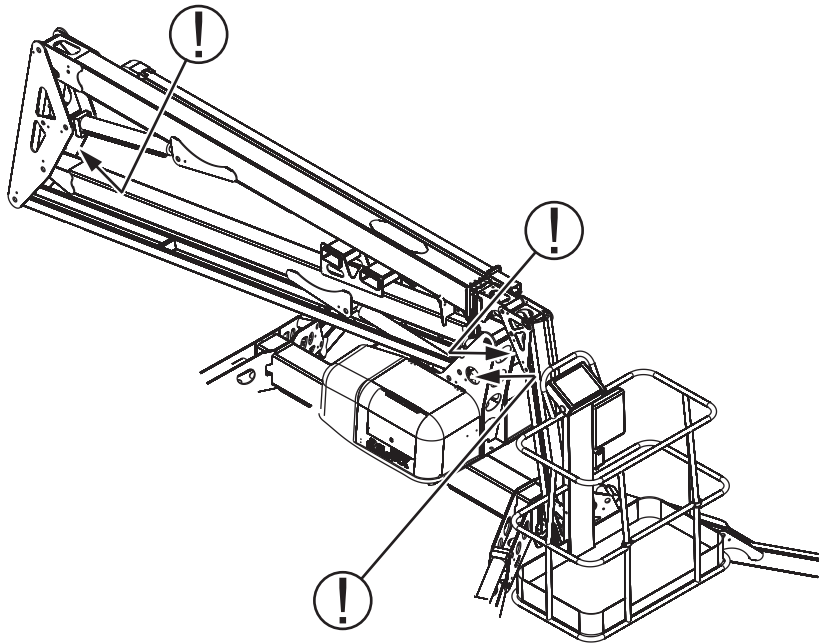

**Figure 3-8. Manual Lowering Valve**

## BATTERY RECHARGE

Recharge batteries as needed. When using the gas engine, press the GENERATOR button on the platform control station to charge the batteries. Charge daily under normal use. When machine is not in use, batteries should be recharged at least once per week. Under normal circumstances, battery recharge should take approximately 10-12 hours. However, a full recharge may take up to 24 hours if the battery charge is extremely low.

### **!** WARNING

**Recharge batteries in a well-ventilated area only. Do not charge batteries near fire, spark or other potential ignition sources. Batteries may emit highly explosive hydrogen gas while charging. Failure to properly ventilate the charge gases may result in serious injury or death. Always charge boom lift batteries away from flammable materials.**

To recharge the boom lift batteries:

- ❑ Move the boom lift to a well-ventilated area with direct access to 120 V electrical outlet. Keep the boom lift and batteries away from open flame or other potential ignition sources.
- ❑ Attach a 12 AWG multi-strand, grounded extension cord with a maximum length of 15 meters to the receptacle located inside the engine compartment. The generator may need to be disconnected from the receptacle.

**NOTE: Using an underrated or long power cord will reduce the output of the battery charger and may extend charge time.**

- ❑ Plug the extension cord into outlet. Verify that the green CHARGING indicator LED is lit on the battery charger faceplate (Figure 3-9).

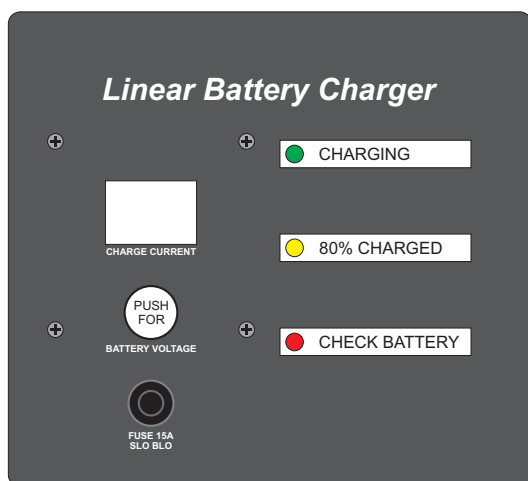

**Figure 3-9. Battery Charger Faceplate**

- ❑ The CHARGING indicator LED remains lit continuously during the first stage of the charge cycle. The bulk mode CHARGE CURRENT will be displayed on the battery charger faceplate.
- ❑ Press and hold the BATTERY VOLTAGE button to display the detected battery voltage.
- ❑ If a battery fault is detected, the appropriate fault code will appear on the CHARGE CURRENT display. The red CHECK BATTERY indicator LED will become lit. See Table 3-1 for battery charger fault codes.

### **!** WARNING

**Do not disconnect any output leads or connectors between the batteries and the charger when the charger is on. To stop a charge in progress, always unplug the extension cord from the AC power source.**

- ❑ When the battery charge reaches 80% of capacity, the yellow 80% CHARGED indicator LED will become lit and the green CHARGING indicator LED will begin to flash.
- ❑ When the batteries have reached a full charge, the green and yellow indicator LEDs will turn themselves off. CC (Charge Complete) will appear on the CHARGE CURRENT display. After two hours, this display will fade and the CHARGE CURRENT will read 00.
- ❑ Unplug the extension cord from the outlet and the charger receptacle on the boom lift. Store the extension cord for next use.

### **!** CAUTION

**Always unplug the battery charger power cord before moving the boom lift. Failure to disconnect power cord will cause damage to the equipment.**

**Table 3-1. Charger Fault Codes**

Code	Description	Limits	Cause
F1	Over Voltage	>112% charge voltage	Loose battery or charger connection
F2	Over Current	>60 amperes	Battery Fault
F3	Bulk Mode Timeout	14 hrs Max.	Battery Fault
F4	ARD Mode Timeout	6 hrs Max.	Battery Fault
F5	FCT Mode Timeout	2.5 hrs Max.	Battery Fault
F6	Self-Test Error		Charger Fault

## BOOM LIFT TRANSPORT

### LIFTING INSTRUCTIONS

Refer to Figure 3-10.

- ❑ Completely lower and retract booms.
- ❑ Secure boom and platform travel latches.
- ❑ Remove all loose materials from machine.
- ❑ Retract all outriggers to fully stowed position.
- ❑ Attach rigging only to the designated forklift pockets (A).
- ❑ Adjust rigging to keep the machine level and to minimize the risk of damage to machine.
- ❑ When using a forklift, use only the designated forklift pockets. Follow all forklift operating instructions as indicated by the forklift manufacturer.
- ❑ Only trained and authorized personnel should attempt to lift the boom using a crane or forklift.

### TRANSPORT INSTRUCTIONS

Refer to Figure 3-10.

- ❑ Verify that truck or trailer is parked on a firm and level surface.
- ❑ Completely lower and retract boom.
- ❑ Secure boom travel latches.
- ❑ Retract all outriggers to fully stowed position.
- ❑ Load boom onto truck or trailer.
- ❑ Secure the boom lift to the trailer bed using straps or chains. Use only the two attachment points beneath the machine, adjacent to the outriggers (B).
- ❑ Adjust as necessary to prevent damage to rigging or machine.

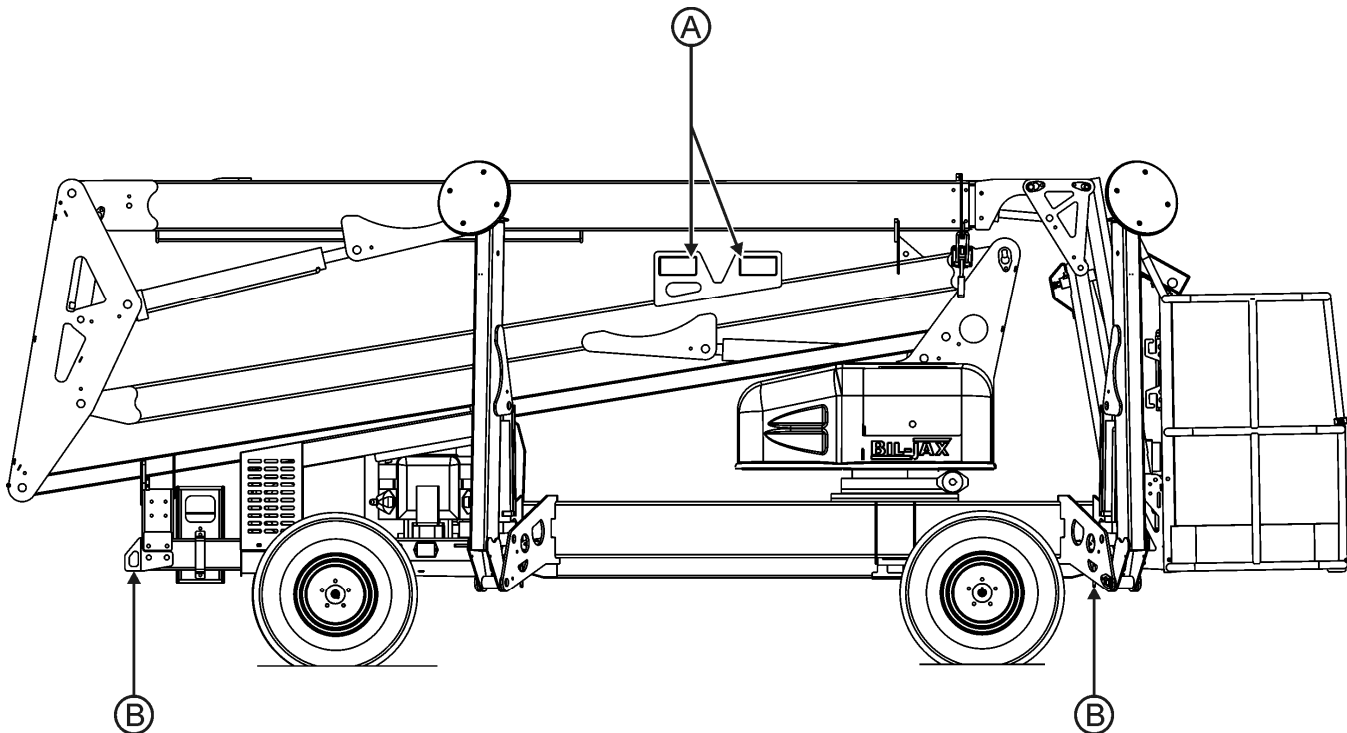

Figure 3-10. Lift and Transport Instructions



# 4 TROUBLESHOOTING

---

The following section contains information for solving basic diagnostic issues associated with the machine. If any issue or malfunction is encountered during the correct and proper operation of the aerial work platform that is not covered by the troubleshooting steps covered in this manual, contact your regional BilJax representative or the BilJax Service Department.

- ❑ All maintenance and repairs should be performed by qualified personnel in accordance with manufacturer specifications and government regulations.
- ❑ Follow recommended maintenance safety guidelines when performing maintenance on the machine.



## TROUBLESHOOTING

Refer to Table 4-1 for basic troubleshooting operations. Additional information can be found in the BilJax Model 45XA Parts and Service Manual. Contact the BilJax Service Department with any questions or before attempting any advanced troubleshooting operations.

**Table 4-1. Troubleshooting Steps**

<b>PROBLEM</b>	<b>CAUSE</b>	<b>SOLUTION</b>
No lights on panel when key switch is turned to the on position.	<ul style="list-style-type: none"> <li>a. Emergency STOP engaged.</li> <li>b. Battery charge is low.</li> <li>c. Battery ground or in-series cable is loose.</li> <li>d. Battery main disconnect unplugged.</li> <li>e. Blown fuse.</li> </ul>	<ul style="list-style-type: none"> <li>a. Disengage Emergency STOP buttons.</li> <li>b. Recharge as needed.</li> <li>c. Inspect and repair battery connections.</li> <li>d. Plug in main disconnect.</li> <li>e. Replace fuse.</li> </ul>
Hydraulic function does not work and display window shows an error message	<ul style="list-style-type: none"> <li>a. Fault detected by safety interlock microprocessor.</li> <li>b. Boom Lift electric or electronic failure</li> </ul>	<ul style="list-style-type: none"> <li>a. Refer to Table 4-2 for error code definition and correction.</li> <li>b. Refer to Table 4-2 for error code definition and correction.</li> </ul>
Outrigger indicator LED lights do not function.	<ul style="list-style-type: none"> <li>a. Key switch turned to the OFF or platform controls position.</li> <li>b. Emergency STOP engaged.</li> <li>c. Outriggers not deployed.</li> </ul>	<ul style="list-style-type: none"> <li>a. Turn key switch to ground controls position.</li> <li>b. Disengage emergency STOP buttons.</li> <li>c. Deploy all outriggers.</li> </ul>
<p>One or more boom controls do not function</p> <p><b>OR</b></p> <p>One or more boom controls function improperly</p> <p><b>OR</b></p> <p>One or more boom controls function intermittently.</p>	<ul style="list-style-type: none"> <li>a. Key switch is turned to the OFF or incorrect control position.</li> <li>b. Battery charge is low.</li> <li>c. Emergency STOP engaged.</li> <li>d. Battery ground or in-series cable loose.</li> <li>e. All outriggers not properly deployed.</li> <li>f. Hydraulic pump inoperative.</li> <li>g. Loose wiring connector.</li> <li>h. Valve solenoid not operating properly.</li> <li>i. Fault detected by system interlock.</li> <li>j. Broken or loose wire.</li> </ul>	<ul style="list-style-type: none"> <li>a. Turn key switch to ground or platform controls position.</li> <li>b. Recharge battery.</li> <li>c. Disengage Emergency STOP buttons.</li> <li>d. Inspect and repair battery connections.</li> <li>e. Deploy all outriggers and level boom lift.</li> <li>f. Inspect pump; replace or repair as needed.</li> <li>g. Check wiring terminals in control box and at valve manifold; replace or repair as needed.</li> <li>h. Clean valve solenoid and recheck function(s); replace or repair as needed.</li> <li>i. Check display for system status. Refer to Table 4-2 for error code definitions and correction.</li> <li>j. Inspect wiring in control box and at valve manifold and valve coil; repair or replace as needed.</li> </ul>

## ERROR CODE DEFINITIONS

The DISPLAY PANEL located on the ground control panel indicates the present operating status of the boom lift. If an error condition is detected by the control processor during start-up or operation, the appropriate error code will be displayed on this panel.

Refer to Table 4-2 for a comprehensive list of Error Code Definitions and solutions.

**Table 4-2. Error Code Definitions**

ERROR MESSAGE	DEFINITION OF ERROR	COMMENTS
001 MACHINE IS IN DOWN ONLY MODE	Machine was either never leveled, outriggers not lowered, or machine went out of level with use.	Retract boom to travel position and extend outriggers using AUTO LEVEL button.
002 LOSS OF PLATFORM COMMUNICATION	Ground control lost communication with platform control.	Check for unplugged or damaged platform control cable.
005 PLATFORM CONTROL HAS STUCK KEY	Platform control detected a stuck or pressed key on power up.	Turn key switch off and on again without pressing any buttons.
008 GROUND CONTROL HAS STUCK KEY	Ground control detected a stuck or pressed key on power up.	Turn key switch off and on again without pressing any buttons.
009 BOOM UP WITHOUT OUTRIGGERS ON GROUND	Ground control detected the boom is up and all outriggers are not on the ground	Retract boom to travel position and extend outriggers using AUTO LEVEL button.
010 LEVEL SENSOR HAS ERRATIC OUTPUT	The ground control detected an erratic output from the level sensor.	Retract and extend outriggers using AUTO LEVEL button.
015 MACHINE IS NOT LEVEL	Machine has gone out of level with use.	Retract and extend outriggers using AUTO LEVEL.
016 LIFT BOOM	A boom rotate, extend, or retract function requested with boom down.	Raise boom from travel position.
017 STOW BOOM	An outrigger function requested with boom up.	Retract and lower boom to travel position.
021 OPEN CIRCUIT PRIMARY UP	A load of less than 70mA detected in primary up circuit on power-up.	Check for faulty boom up solenoid coil and wiring.
022 SHORTED CIRCUIT PRIMARY UP	Excessive load detected in primary up circuit on power-up.	Check for faulty boom up solenoid coil and wiring.
023 OPEN CIRCUIT PRIMARY DOWN	A load of less than 70mA was detected when primary down circuit was energized	Check for faulty boom down solenoid coil and wiring.
024 SHORTED CIRCUIT PRIMARY DOWN	Excessive load detected when primary down circuit was energized.	Check for faulty boom down solenoid coil and wiring.
025 OPEN CIRCUIT SECONDARY UP	A load of less than 70mA detected in secondary up circuit on power-up.	Check for faulty boom up solenoid coil and wiring.
026 SHORTED CIRCUIT SECONDARY UP	Excessive load detected in secondary up circuit on power-up.	Check for faulty boom up solenoid coil and wiring.
027 OPEN CIRCUIT SECONDARY DOWN	A load of less than 70mA detected when secondary down circuit was energized	Check for faulty boom down solenoid coil and wiring.
028 SHORTED CIRCUIT SECONDARY DOWN	Excessive load detected when secondary down circuit was energized.	Check for faulty boom down solenoid coil and wiring.
029 OPEN CIRCUIT JIB UP	A load of less than 70mA detected in jib up circuit on power-up.	Check for faulty jib up solenoid coil and wiring.
030 SHORTED CIRCUIT JIB UP	Excessive load detected in jib up circuit on power-up.	Check for faulty jib up solenoid coil and wiring.

ERROR MESSAGE	DEFINITION OF ERROR	COMMENTS
031 OPEN CIRCUIT JIB DOWN	A load of less than 70mA detected when jib down circuit was energized	Check for faulty jib down solenoid coil and wiring.
032 SHORTED CIRCUIT JIB DOWN	Excessive load detected when jib down circuit was energized.	Check for faulty jib down solenoid coil and wiring.
033 OPEN CIRCUIT EXTEND	A load of less than 70mA detected in extend circuit on power-up.	Check for faulty boom extend solenoid coil/wiring.
034 SHORTED CIRCUIT EXTEND	Excessive load detected in extend circuit on power-up.	Check for faulty boom extend solenoid coil/wiring.
035 OPEN CIRCUIT RETRACT	A load of less than 70mA detected in retract circuit on power-up.	Check for faulty boom retract solenoid coil/wiring.
036 SHORTED CIRCUIT RETRACT	Excessive load detected in retract circuit on power-up.	Check for faulty boom retract solenoid coil/wiring.
037 OPEN CIRCUIT PLATFORM LEVEL UP	A load of less than 70mA detected in platform level up circuit on power-up.	Check for faulty level up solenoid coil/wiring.
038 SHORTED CIRCUIT PLATFORM LEVEL UP	Excessive load detected in platform level up circuit on power-up.	Check for faulty level up solenoid coil/wiring.
039 OPEN CIRCUIT PLATFORM LEVEL DOWN	A load of less than 70mA detected in platform level down circuit on power-up.	Check for faulty level down solenoid coil/wiring.
040 SHORTED CIRCUIT PLATFORM LEVEL DOWN	Excessive load detected in platform level down circuit on power-up.	Check for faulty level down solenoid coil/wiring.
041 OPEN CIRCUIT PLATFORM CW	A load of less than 70mA detected in platform CW circuit on power-up.	Check for faulty boom rotate solenoid coil/wiring.
042 SHORTED CIRCUIT PLATFORM CW	Excessive load detected in platform CW circuit on power-up.	Check for faulty boom rotate solenoid coil/wiring.
043 OPEN CIRCUIT PLATFORM CCW	A load of less than 70mA detected in platform CCW circuit on power-up.	Check for faulty boom rotate solenoid coil/wiring.
044 SHORTED CIRCUIT PLATFORM CCW	Excessive load detected in platform CCW circuit on power-up.	Check for faulty boom rotate solenoid coil/wiring.
045 OPEN CIRCUIT TURNTABLE CW	A load of less than 70mA detected in rotate CW circuit on power-up.	Check for faulty rotate CW solenoid coil/wiring.
046 SHORTED CIRCUIT TURNTABLE CW	Excessive load detected in rotate CW circuit on power-up.	Check for faulty rotate CW solenoid coil/wiring.
047 OPEN CIRCUIT TURNTABLE CCW	A load of less than 70mA detected in rotate CCW circuit on power-up.	Check for faulty rotate CCW solenoid coil/wiring.
048 SHORTED CIRCUIT TURNTABLE CCW	Excessive load detected in rotate CCW circuit on power-up.	Check for faulty rotate CCW solenoid coil/wiring.
049 OPEN CIRCUIT OUTRIGGER RETRACT	A load of less than 70mA detected in outrigger retract circuit on power-up.	Check for faulty outrigger retract solenoid coil/wiring.
050 SHORTED CIRCUIT OUTRIGGER RETRACT	Excessive load was detected when Outrigger Retract circuit was energized.	Check for faulty outrigger retract solenoid coil/wiring.
051 OPEN CIRCUIT OUTRIGGER EXTEND	A load of less than 70mA detected in outrigger retract circuit on power-up.	Check for faulty outrigger extend solenoid coil/wiring.
052 SHORTED CIRCUIT OUTRIGGER EXTEND	Excessive load was detected in outrigger extend circuit on power-up.	Check for faulty outrigger extend solenoid coil/wiring.
053 OPEN CIRCUIT LF OUTRIGGER	A load of less than 70mA detected in left front outrigger circuit on power-up.	Check for faulty solenoid coil/wiring at outrigger.
054 SHORTED CIRCUIT LF OUTRIGGER	Excessive load was detected in left front outrigger circuit on power-up.	Check for faulty solenoid coil/wiring at outrigger.
055 OPEN CIRCUIT RF OUTRIGGER	A load of less than 70mA detected in right front outrigger circuit on power-up.	Check for faulty solenoid coil/wiring at outrigger.

ERROR MESSAGE	DEFINITION OF ERROR	COMMENTS
056 SHORTED CIRCUIT RF OUTRIGGER	Excessive load detected in right front outrigger circuit on power-up.	Check for faulty solenoid coil/wiring at outrigger.
057 OPEN CIRCUIT LR OUTRIGGER	A load of less than 70mA detected in left rear outrigger circuit on power-up.	Check for faulty solenoid coil/wiring at outrigger.
058 SHORTED CIRCUIT LR OUTRIGGER	Excessive load detected in left rear outrigger circuit on power-up.	Check for faulty solenoid coil/wiring at outrigger.
059 OPEN CIRCUIT RR OUTRIGGER	A load of less than 70mA detected in right rear outrigger circuit on power-up.	Check for faulty solenoid coil/wiring at outrigger.
060 SHORTED CIRCUIT RR OUTRIGGER	Excessive load detected in right rear outrigger circuit on power-up.	Check for faulty solenoid coil/wiring at outrigger.
069 OPEN CIRCUIT PROPORTIONAL	A load of less than 70mA detected in proportional valve circuit on power-up.	Check for faulty solenoid coil/wiring at proportional valve.
070 SHORTED CIRCUIT PROPORTIONAL	Excessive load detected in proportional valve circuit on power-up.	Check for faulty solenoid coil/wiring at proportional valve.



# 5 DECAL REPLACEMENT

---

Decals contain information that is required for the safe and proper use of the aerial work platform. Decals should be considered necessary components of the machine and should be checked before each use to verify that they are correctly attached and legible.

Use the following guides to find the correct location of all decals.

Table 5-1. Decal Descriptions

Decal No.	Decal Description	Qty	Decal No.	Decal Description	Qty
0202-0523	Made in USA	1	B06-00-0484	DANGER: Battery/Charger Safety	1
B06-00-0034	DANGER: Electric Shock	1	B06-00-0494	NOTICE: Hazardous Materials	1
B06-00-0037	Lubricate Semi-Annually	1	B06-00-0495	CAUTION: Compartment Access Restricted	2
B06-00-0062	NOTICE: AC Power	2	B06-00-0503	NOTICE: Handle Applications	1
B06-00-0068	NOTICE: Hydraulic System Oil	1	B06-00-0504	NOTICE: Emergency Hand Pump	1
B06-00-0161B	BilJax Logo, Black Transfer	2	B06-00-0505	DANGER: Before Use/Main Instruction/Hazards (ground)	1
B06-00-0403	NOTICE: Emergency Lowering	4	B06-00-0521	DANGER: Tip Over Hazard	5
B06-00-0404	WARNING: Outrigger Crush Toe	8	B06-00-0536	NOTICE: Range of Motion	2
B06-00-0405	WARNING: Pinch Point	16	B06-00-0541	CAUTION: Manual Boom Functions	1
B06-00-0471	DANGER: Before Use/Main Instruction/Hazards (Platform)	1	B06-00-0545	BilJax Website Transfer	2
B06-00-0473	NOTICE: Operator's Manual Missing	1	B06-00-0552	NOTICE: Fall Protection Attachment Points	1
B06-00-0474	NOTICE: Max. Load	1	B06-00-0561	WARNING: Operating Instructions (Ground)	2
B06-00-0475	WARNING: Read/Understand Operator's Manual	1	B06-00-0562	WARNING: Operating Instructions (Platform)	1
B06-00-0477	WARNING: Forklift Pockets	2	B06-00-0564	45XA, 6" Black Transfer	2
B06-00-0481	CAUTION: Transport Safety Latch	2			
B06-00-0482	DANGER: Electrocutation Hazard	2			

#### Identification Plates

B06-00-0490	VIN Plate	1
B06-00-0499	ANSI ID Plate	1
B06-00-0524	Annual Inspection Plate	1
B06-00-0526	Key Tag	1

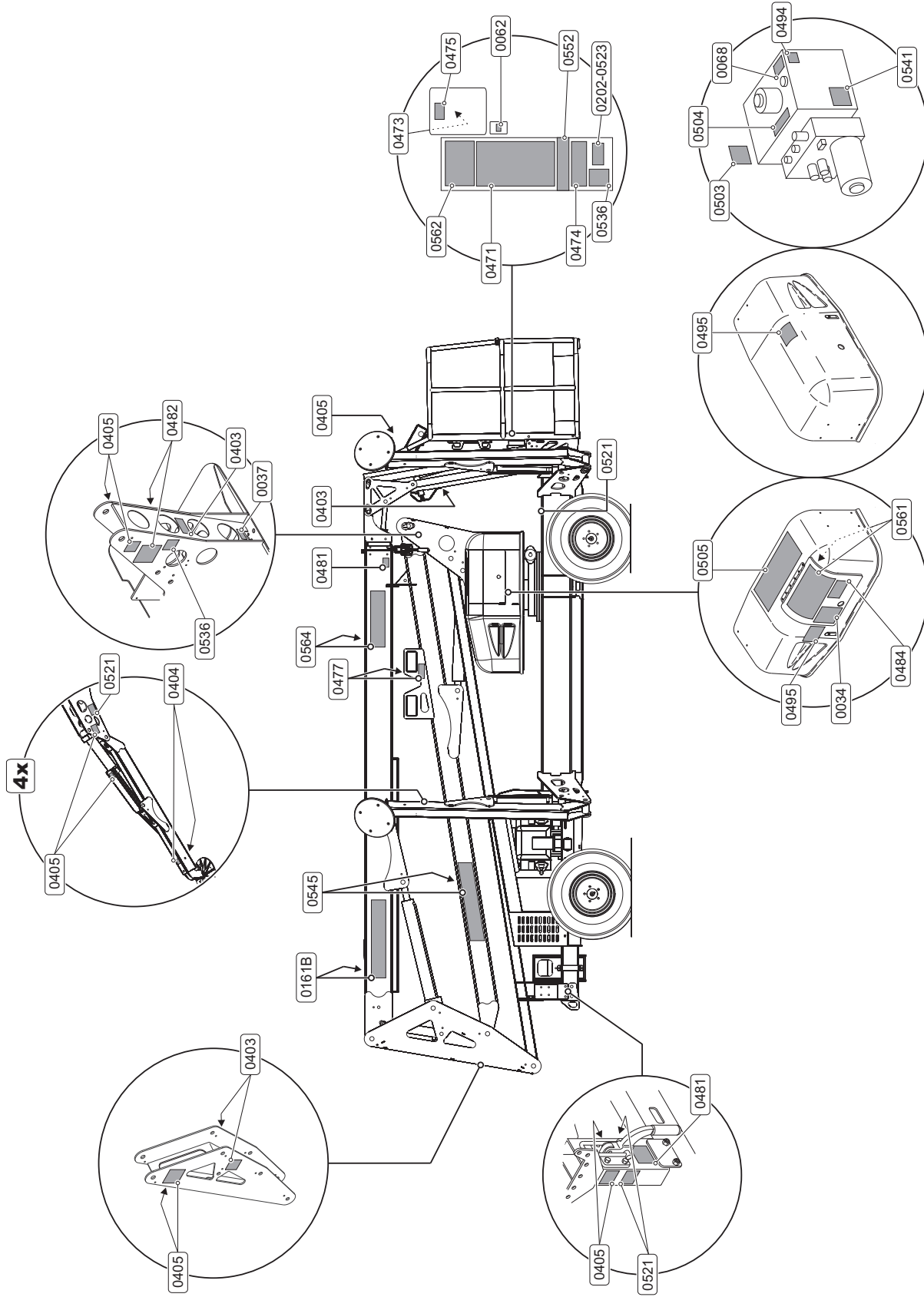

Figure 5-1. Decal Placement



Table 5-2. Decal Descriptions – CE

Decal No.	Decal Description	Qty
0202-0523	Made in USA	1
B06-00-0034	DANGER: Electric Shock	2
B06-00-0037	Lubricate Semi-Annually	1
B06-00-0062	NOTICE: AC Power	2
B06-00-0068	NOTICE: Hydraulic System Oil	1
B06-00-0161B	BilJax Logo, Black Transfer	2
B06-00-0173	Fall Protection Attachment Points	1
B06-00-0403	NOTICE: Emergency Lowering	4
B06-00-0404	WARNING: Outrigger Crush Toe	8
B06-00-0405	WARNING: Pinch Point	15
B06-00-0471	DANGER: Before Use/Main Instruction/Hazards (Platform)	1
B06-00-0474	NOTICE: Max. Load	1
B06-00-0475	WARNING: Read/Understand Operator's Manual	2

Decal No.	Decal Description	Qty
B06-00-0482	DANGER: Electrocutation Hazard	2
B06-00-0495	CAUTION: Compartment Access Restricted	2
B06-00-0505	DANGER: Before Use/Main Instruction/Hazards (ground)	1
B06-00-0536	NOTICE: Range of Motion	2
B06-00-0541	CAUTION: Manual Boom Functions	1
B06-00-0545	BilJax Website Transfer	2
B06-00-0561	WARNING: Operating Instructions (Ground)	2
B06-00-0562	WARNING: Operating Instructions (Platform)	1
B06-00-0564	45XA, 6" Black Transfer	2
B06-00-0568	WARNING: Outrigger Pressure	4
B06-00-0572	WARNING: Read/Understand Parts and Service Manual	1

#### Identification Plates

B06-00-0499	ANSI ID Plate	1
B06-00-0526	Key Tag	1

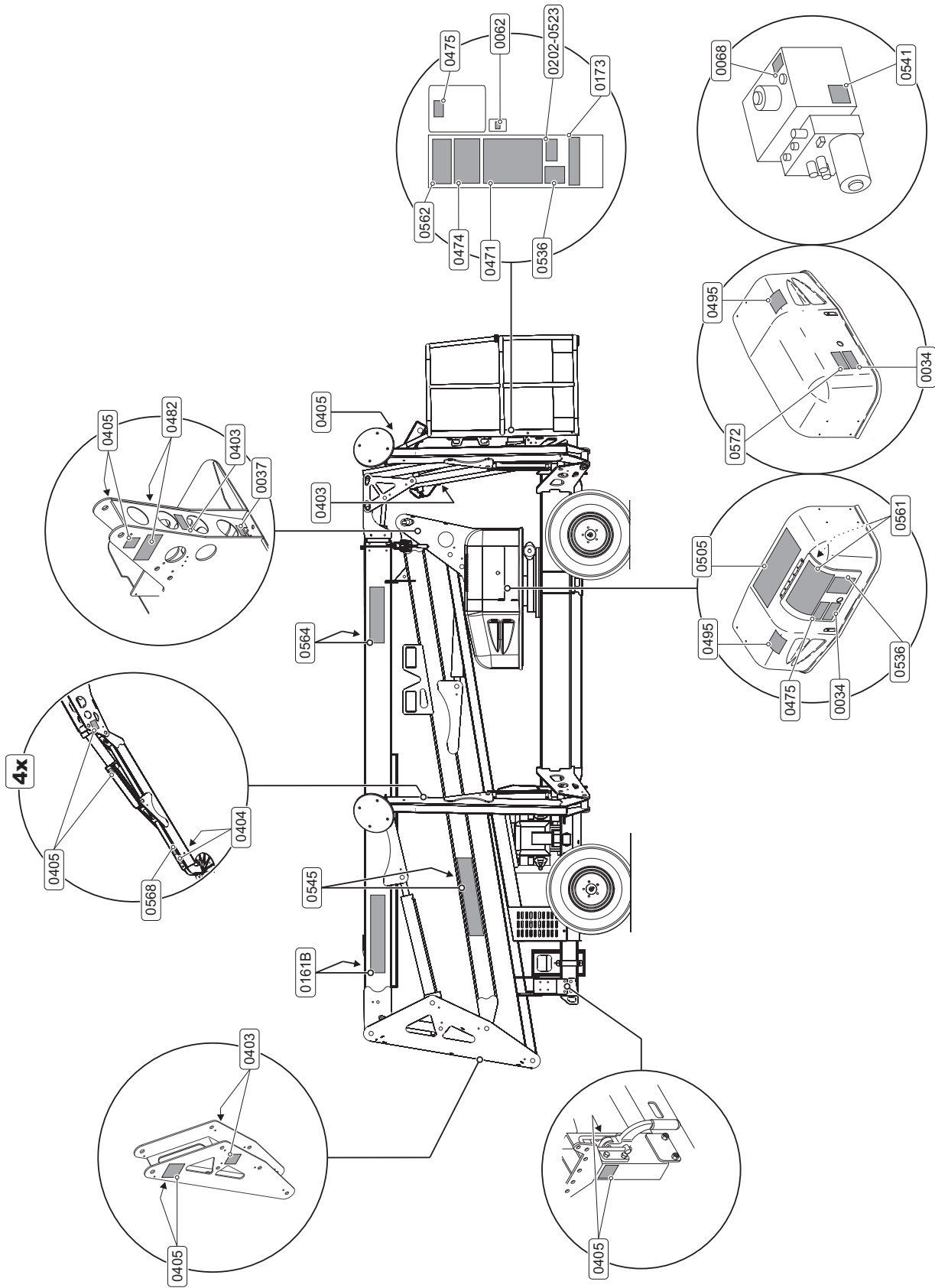

Figure 5-2. Decal Placement – CE



# 6 SPECIFICATIONS

---

BilJax, Inc. is dedicated to the continuous improvement of this and all BilJax products. Therefore, equipment information is subject to change without notice.

The following information is based on ideal working conditions. Machine performance may vary based on work environment and on machine options.

Direct any questions or concerns regarding equipment specifications to your regional BilJax representative or to the BilJax Service Department.

## SPECIFICATIONS

SERIAL NUMBER \_\_\_\_\_

<b>Working Height</b>	51 ft 15.7 m	<b>Outrigger Footprint</b>	
<b>Maximum Platform Height</b>	45 ft 13.7 m	Length	12 ft 2 in 3.7 m
<b>Maximum Horizontal Outreach</b>		Width	11 ft 4 in 3.4 m
From Centerline	27 ft 8.2 m	Footpad Diameter	12.5 in 0.3 m
From Outrigger Footpad Edge	21 ft 6.4 m	<b>Brake</b>	Spring Applied
<b>Rated Platform Capacity</b>		<b>Speed</b>	
Without Platform Rotation	500 lbs 227 kg	Gas Power	3.75 mph 6 km/h
With Platform Rotation	440 lbs 200 kg	DC Power	2 mph 3.2 km/h
<b>Maximum Occupants</b>	2	<b>Tire Size</b>	26 x 12 bar lug tires
<b>Total Weight</b>	4,300 lbs 1,950 kg	<b>Tire Pressure</b>	20 PSI 140 kPa
<b>Turntable Rotation</b>	700° Non-Continuous	<b>Control System</b>	24V DC
<b>Leveling Capability</b>	12.5°	<b>Battery</b>	4 x 6V 245 amp-hr
<b>Gradeability</b>	48%	<b>Battery Charger</b>	110/120 Volt
<b>Wheel Base</b>	8 ft 8 in 2.7 m	<b>Gas Engine</b>	Kawasaki 21 HP
<b>Turning Radius</b>		<b>Hydraulic Pressure</b>	3,000 psi 20,684 kPa
Inside	11 ft 3.35 m	<b>Reservoir Capacity</b>	4.3 Gallons 16.3 L
Outside	16 ft 8 in 5 m	<b>Hydraulic System Capacity</b>	6.3 Gallons 23.9 L
<b>Platform Dimensions</b>		<b>Hydraulic Oil (Standard)</b>	Dexron III/Mercon ATF
Height	3 ft 7 in 1.1 m	<b>Platform Rotation/Type (Optional)</b>	90°/Manual
Length	2 ft 6 in 0.8 m	<b>Maximum Decibel Level</b>	
Width – US/CE	5 ft/4 ft 1.5 m/1.2 m	DC Mode – Ground	60 dB
<b>Stowed Dimensions</b>		DC Mode – Platform	55 dB
Height	6 ft 4 in 2.0 m	Gas Mode – Ground	70 dB
Length	19 ft 2 in 5.8 m	Gas Mode - Platform	65 dB
Width	5 ft 5 in 1.7 m	<b>Localized Pressure per Outrigger</b>	25 PSI 1.8 kg/cm <sup>2</sup> 176.5 kPa
		<b>Operation Temperature Range</b>	-20° to 110° Fahrenheit -29° to 43° Celsius
		<b>Max. Pressure Per Tire – Floor Loading</b>	35 PSI 2.5 bar

### RANGE OF MOTION

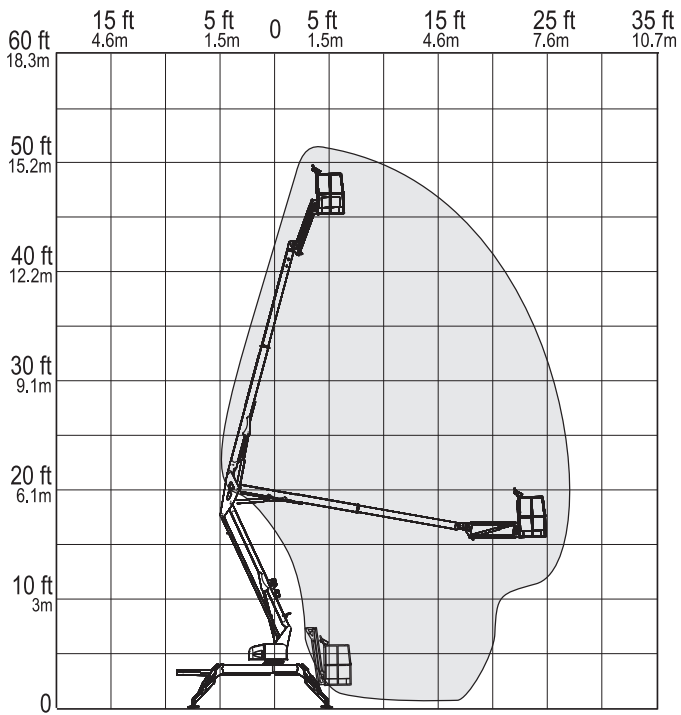

Figure 7-1. Range of Motion

# 7 EQUIPMENT OPTIONS

---

The BilJax Model 45XA may be equipped with one or more optional components designed for the convenience and safety of operators when using the equipment to accomplish specific tasks.

Always use only those components manufactured and/or authorized by BilJax, Inc. Never make any adjustments or modifications or otherwise alter the equipment in any way that is not expressly recommended by the manufacturer.

When operating a machine equipped with optional components, observe all safety precautions set forth by the manufacturer, as well as all government codes and regulations regarding this equipment and its components.

Consult rental agency or equipment manufacturer regarding which optional components may be installed on the boom lift. For questions regarding safe use, contact your regional BilJax dealer before attempting operation

## MATERIAL LIFTING HOOK

If the boom lift is equipped with a material lifting hook, observe the following procedure for material lift operation:

- ❑ Remove platform controls from the work platform by releasing the latch on the back of the platform control box.
- ❑ Disconnect platform control box from the load sense module located on the boom lift bulkhead.
- ❑ Remove the electric loopback plug from the receptacle on the bottom right of the ground control panel (Figure 8-1) and insert the platform control cable into the open receptacle.

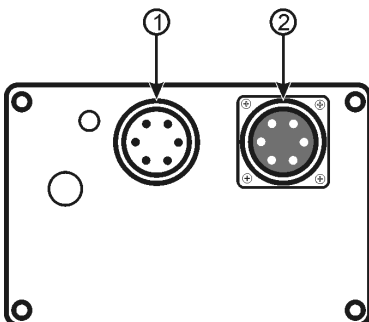

### 1. To Boom Cable.

Do Not Remove.

### 2. To Platform Controls.

- a. Disconnect platform controls.
- b. Replace with loopback plug from ground controls.
- c. Plug platform controls into open receptacle on the bottom right of ground control panel.

**Figure 8-1. Material Lifting Hook Configuration**

- ❑ Insert the removed electric loopback plug into the open receptacle on the load sense module, replacing the platform control cable.
- ❑ Remove the retaining pin holding the platform to boom lift. Firmly secure platform to prevent equipment damage.
- ❑ Remove the platform from the boom by lifting cage up and away from the mounting bracket on the boom nose.
- ❑ Attach the material lifting hook to the mounting bracket on the boom nose and insert the retaining pin (Figure 8-2).

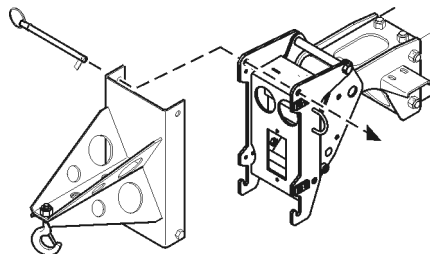

**Figure 8-2. Material Lifting Hook Installation**

- ❑ Operate the material lifting hook remotely, using the platform control box for optimal control.

### **! WARNING**

Always observe the manufacturer's weight lifting limitations when using the material lifting hook. Always use lifting straps or wire rope slings that are rated at a minimum 500 lbs lifting capacity. Never stand beneath an elevated load or position an elevated load above personnel. Falling objects can cause serious injury or death.

### **⚡ DANGER**

This machine is not insulated for use near electrical power lines and DOES NOT provide protection from contact with or close proximity to any electrically charged conductor. Operator must maintain safe clearances at all times and always allow for platform movement such as wind-induced sway. Refer to Table 1-1 for minimum safe approach distances between the machine and electrical power lines.

- ❑ Reverse the procedure to reattach the work platform.



## PLATFORM ROTATOR

The optional platform rotator allows the operator to rotate the elevated work platform 90° around a vertical axis by actuating a rotator handle found below the platform control panel.

To operate manual platform rotator, turn the rotator handle in the direction of desired rotation (clockwise or counterclockwise). Motion continues in the desired direction until rotator handle is released or the platform reaches a safe travel limit.

### **⚠ WARNING**

**Installation of a manual platform rotator may reduce the rated load limit of the work platform. Follow all manufacturer's recommendations and safety precautions when operating a boom lift equipped for platform rotation.**

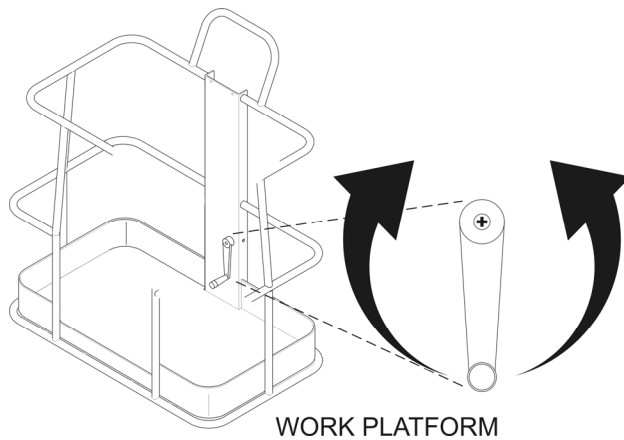

**Figure 8-3. Manual Platform Rotator**



NOTES

**Haulotte**   
G R O U P

125 Taylor Parkway  
Archbold, OH 43502  
Phone (419) 445-8915  
(800) 537-0540  
Fax (419) 445-0367

<http://www.biljax.com>

**BILJAX**

Distributed by: