

PARTS AND SERVICE MANUAL

Haulotte 
GROUP

BILJAX

55XA / HLA 19 PX

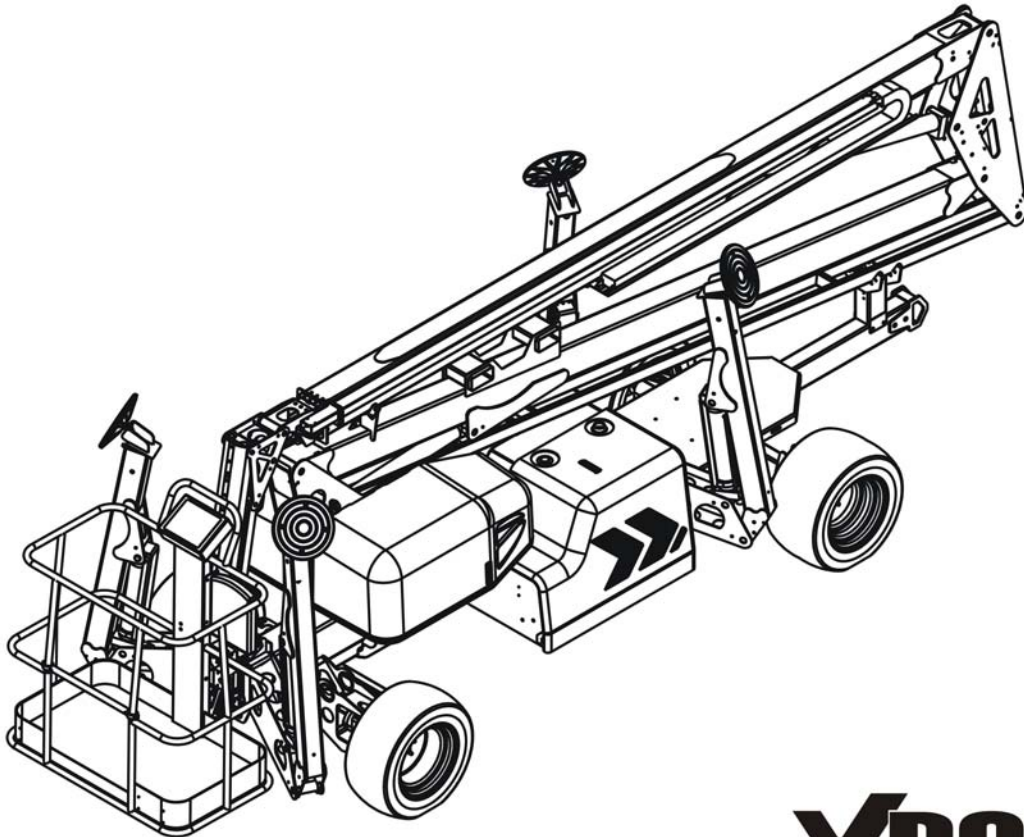

X-BOOM
AERIAL WORK PLATFORMS®

BOOM PERSONNEL LIFT

This equipment is designed and manufactured in compliance with the duties, responsibilities and standards set forth in the ANSI and CSA standards in effect at the time of manufacture.

This equipment will meet or exceed applicable ANSI and CSA codes and standards when operated in accordance with manufacturer's recommendations.

It is the responsibility of the user to follow all regional codes and regulations that govern the safe operation of this equipment.

Obtain, read and obey all safety precautions before performing maintenance or repairs or attempting to operate this equipment. This includes all manufacturer recommendations as well as those directives set forth by government and local authorities.

To ensure proper and safe use of this equipment, it is strongly recommended that only trained and authorized personnel attempt to operate and maintain the boom lift.

This manual shall be considered a permanent and necessary component of the machine and shall be kept with the boom lift at all times.

Owners and Lessors should complete a full inspection of all components and perform a test of all functions, including brake functions, before commissioning or reselling the machine. Repair or replace all damaged or malfunctioning components.

Haulotte Group | BilJax, is dedicated to the continuous improvement of this and all Haulotte Group | BilJax products. Therefore, equipment information is subject to change without notice. Direct any questions or concerns regarding errors or discrepancies in this manual to the Haulotte Group | BilJax Service Department.

Copyright © Haulotte Group | BilJax, Inc. 2009. All Rights Reserved.

"Haulotte Group | BilJax" is a registered trademark and "X – Boom Aerial Work Platforms" and "Summit Series" are trademarks of Haulotte Group | BilJax. Contact Haulotte Group | BilJax for replacement manuals.



125 Taylor Parkway
Archbold, Ohio 43502
Phone : (800) 537-0540
(419) 445-8915
Fax.: (419) 445-0367

P/N: B33-01-0113-01

TABLE OF CONTENTS

TABLE OF CONTENTS	1
LIST OF ILLUSTRATIONS	2
LIST OF TABLES	2
1 SAFETY	3
LEGEND: SAFETY ADVISORIES.....	3
BEFORE OPERATION.....	4
MAINTENANCE SAFETY.....	5
DAMAGED EQUIPMENT POLICY	6
2 SPECIFICATIONS	9
RANGE OF MOTION.....	9
SPECIFICATIONS.....	10
WARRANTY	12
3 EQUIPMENT MAINTENANCE	13
DAILY SERVICE CHECKS	14
WEEKLY SERVICE CHECKS.....	16
MONTHLY SERVICE CHECKS	17
ANNUAL SERVICE CHECKS	17
STRUCTURAL INSPECTION	18
ADDITIONAL SERVICE INFORMATION.....	19
BATTERY RECHARGE.....	19
CHARGER FAULT CODES.....	21
MANUAL BOOM OPERATION	22
TROUBLESHOOTING.....	24
ERROR CODE DEFINITIONS	25
MOTOR CONTROLLER FAULT CODE DEFINITIONS.....	36
4 CYLINDER REPLACEMENT	39
LIFT CYLINDER REPLACEMENT	40
OUTRIGGER CYLINDER REPLACEMENT.....	42
5 REPLACEMENT DECALS	43
6 REPLACEMENT PARTS	49
7 EQUIPMENT OPTIONS	131
8 ANSI REPRINT	147
INSPECTION FORM for Haulotte Group BilJax X-Boom Aerial Work Platforms.....	169
ORDERING REPLACEMENT PARTS	170

LIST OF ILLUSTRATIONS

FIGURE 2-1 RANGE OF MOTION	9
FIGURE 3-1 OUTRIGGER POSITION SWITCHES	15
FIGURE 3-2 HYDRAULIC RESERVOIR	16
FIGURE 3-3 WHEEL NUT TIGHTENING SEQUENCE.....	17
FIGURE 3-4 SLEW RING POSITION MEASUREMENT.....	18
FIGURE 3-5 BATTERY CHARGER FACEPLATE.....	20
FIGURE 3-6 HAND PUMP AND CONTROLS FOR MANUAL LIFT OPERATION	22
FIGURE 3-7 MANUAL LOWERING VALVE	23
FIGURE 3-8 MOTOR CONTROLLERS.....	37
FIGURE 4-1 LIFT CYLINDER REPLACEMENT.....	41
FIGURE 4-2 OUTRIGGER CYLINDER REPLACEMENT	42
FIGURE 5-1 DECAL LOCATIONS.....	44
FIGURE 7-1 MATERIAL LIFTING HOOK CONFIGURATION	136
FIGURE 7-2 MATERIAL LIFTING HOOK INSTALLATION	137
FIGURE 7-3 MANUAL PLATFORM ROTATOR	142
FIGURE 8-1 MINIMUM SAFE APPROACH DISTANCES.....	167

LIST OF TABLES

TABLE 3-1 CHARGER FAULT CODES	21
TABLE 3-2 TROUBLESHOOTING STEPS	24
TABLE 3-3 ERROR CODE DEFINITIONS	25
TABLE 3-4 MOTOR CONTROLLER FAULT CODE DEFINITIONS.....	36
TABLE 5-1 REPLACEMENT DECAL DESCRIPTIONS	45

1 SAFETY

Proper training is required for the safe operation of any mechanical device. Failure to follow all instructions and safety precautions in this manual and attached to the lift will result in death or personal injury.

Prior to Operation:

- Read, understand and obey all instructions and safety precautions in this manual and attached to the lift.
- Read, understand and obey all applicable government regulations.
- Become familiar with the proper use of all controls.
- Inexperienced users should receive instruction before attempting to operate or maintain the machine.

The use of intelligence and common sense is the best practice when following any safety policy.

LEGEND: SAFETY ADVISORIES

The following safety advisories are used throughout this manual to indicate specific hazards when operating or maintaining the machine. Read, understand and obey all safety advisories to prevent improper service, damage to equipment and personal injury or death.



Warns of operation near electrical power sources which if not avoided, will result in death or serious injury.



Indicates a hazardous situation which if not avoided, could result in death or serious injury.



Indicates a hazardous situation which, if not avoided, could result in minor or moderate injury.

NOTICE

Contains information important in the prevention of errors that could damage the machine or its components.

BEFORE OPERATION

Ensure the following general safety precautions are followed before operating the articulating boom lift:

ALWAYS inspect the usage area for potential hazards, such as unstable or unlevel surfaces, overhead obstructions and electrically charged wires or conductors. ALWAYS watch for moving vehicles in the operating area.

ALWAYS conduct a thorough inspection of the machine before operation. Check for damaged or worn parts, hydraulic leaks, damaged wiring, loose wiring conductors, damaged outriggers, low tire pressure, uneven tire wear or tire damage. Check for any improperly operating components. NEVER operate equipment if any damage is observed or suspected. Repair damaged or malfunctioning equipment before operation.

ALWAYS wear proper clothing. Wear protective equipment as required by government regulations. Keep loose clothing, jewelry, gloves and hair away from moving parts.

ALWAYS wear a safety harness and energy-absorbing lanyard, such as the safety harness and lanyard provided by Haulotte Group | BilJax.

ALWAYS inspect platform floor and outrigger footpads for mud, grease, debris or other foreign material. ALWAYS remove any such material from the equipment before operation.

ALWAYS tag any part of the equipment known or suspected to be damaged or malfunctioning. ALWAYS remove a malfunctioning, damaged or defective machine from service. NEVER operate a machine that has any known or suspected defect.

ALWAYS comply with the instructions found in Safety and/or Service Bulletins distributed by the manufacturer. Bulletins may contain critical procedures that supersede the information contained in manuals.

NEVER operate this equipment while under the influence of drugs or alcohol, while taking prescription medications that may leave the operator drowsy or prone to dizziness, or while feeling ill.

NEVER modify, alter or change the equipment in any way that would affect its original design or operation.

NEVER deface, modify or obscure any decals or markings on equipment.

NEVER operate the equipment in any way for which it is not intended.

DURING OPERATION

Ensure the following general safety precautions are followed while operating the articulating boom lift:

ALWAYS position lift away from power lines to ensure that no part of the lift can accidentally reach into an unsafe area. This includes full extension of the boom through 700° rotation.



This machine is NOT insulated for use near electrical power lines and DOES NOT provide protection from contact with or close proximity to any electrically charged conductor. Operator must maintain safe clearances at all times (10 Feet or 3.05 meters minimum) and must always allow for platform movement due to gusty winds. Always contact power company before working near power lines. Assume every power line is live. Power lines can be blown by the wind. Refer to Table 1-1 for minimum safe approach distances between the machine and electrical power lines.

BEFORE OPERATION (Continued)

NEVER sit, stand or climb on cage bars. ALWAYS keep both feet firmly on the work cage floor when working from an elevated platform.

NEVER attempt to increase the working height with boxes, ladders, stools or any other materials.

NEVER operate this equipment when exposed to high winds, thunderstorms, ice or any weather conditions that would compromise operator safety.

NEVER operate boom lift in conditions where wind speeds exceed 28 mph (45 km/h or 12.5 m/sec). Steady or gusty winds that exceed 28 mph (45 km/h or 12.5 m/sec) may affect stability and boom operation.

NEVER allow ropes, electric cords, hoses or other equipment to become entangled in the machine while raising or lowering platform.

NEVER exceed the load limits set by the manufacturer. Use only the Material Lifting Hook, supplied as an option and manufactured by Haulotte Group | BilJax, when lifting materials. Safely stow all tools and equipment.

NEVER exceed load ratings by transferring loads to the lift at elevated heights.

NEVER use the platform to lift a load that exceeds the platform dimensions. NEVER lift a load in such a way that the center of gravity is higher than the top guardrail of the platform.

NEVER modify the platform or carry materials that would increase the surface area of the platform. Increasing the area exposed to the wind may decrease machine stability. NEVER attach over hanging loads when raising or lowering the platform.

NEVER use the boom or platform to push or pull or to lift any part of the trailer.

NEVER use the boom or platform to place a load against any structure, materials or equipment.

NEVER climb on the boom. Refer to Section 3 for the instructions for manual operation.

NEVER leave an elevated platform unattended.

NEVER leave the keys in the boom lift while unattended or not in use.

MAINTENANCE SAFETY

Ensure the following general safety precautions are followed while performing maintenance on the articulating boom lift:

General Maintenance

ALWAYS perform maintenance procedures according to manufacturer's guidelines. NEVER disregard or bypass proper maintenance procedures.

ALWAYS inspect hydraulic system to ensure that all lines, connectors and fittings are properly fastened and in good condition.

ALWAYS turn the key switch OFF and remove key before performing maintenance.

Whenever possible, ALWAYS perform maintenance with the boom and platform in a fully lowered, stowed position. ALWAYS secure the boom before performing maintenance on hydraulic cylinders.

ALWAYS disconnect power to the hydraulic pump drive motor before making electrical checks to the hydraulic valves.

ALWAYS keep all mechanical parts properly adjusted and lubricated according to maintenance schedule and manufacturer's specifications.

ALWAYS perform a function check of operating controls before each use and after repairs have been made.

ALWAYS locate and protect against possible pinch points before performing any maintenance or repairs.

ALWAYS use only manufacturer-approved parts to repair or maintain equipment. If any portion of this equipment is rebuilt or repaired, retesting is required in accordance with factory instructions.

ALWAYS maintain a safe distance while testing the hydraulic components. ALWAYS relieve hydraulic pressure before loosening or removing hydraulic components. NEVER test or operate the hydraulic components while personnel are near the equipment.

MAINTENANCE SAFETY (Continued)

NEVER allow water or foreign particles into the DC electric motor housing. Inclusion of water or foreign particles may cause serious damage to the motor. If the motor becomes wet, consult an authorized Haulotte Group | BilJax service technician for proper drying instructions.

NEVER add unauthorized fluids to the hydraulic system or battery. NEVER mix hydraulic oils. Consult manufacturer specifications. Refer to Section 4 for hydraulic system maintenance procedures.

NEVER exceed the manufacturer's recommended relief valve settings.

NEVER touch or allow metal tools to contact any components that are sensitive to static discharge. ALWAYS use static discharge prevention mats and grounding devices when handling electronic components.

NEVER adjust, repair, replace or bypass any hydraulic or electrical control or safety device. These include, but are not limited to, hydraulic load control and flow control valves, solenoid valves and limit switches. ALWAYS consult an authorized Haulotte Group | BilJax technician if repairs are necessary.

NEVER modify, alter or change the equipment without first consulting an authorized Haulotte Group | BilJax technician, and NEVER in any way that would affect its original design or operation.

Battery Maintenance

Ensure the following general safety precautions are followed when performing battery maintenance on the telescoping boom lift.

ALWAYS check the battery fluid level daily.

ALWAYS wear safety glasses when working with or near batteries.

ALWAYS avoid contact with battery acid. Battery acid causes serious burns and should be kept away from skin or eyes. If contact occurs, flush with water and consult a physician immediately.

ALWAYS disconnect ground cable first when removing battery.

ALWAYS connect ground cable last when installing battery.

ALWAYS charge batteries in open, well-ventilated areas.

ALWAYS replace batteries using only parts recommended by manufacturer. ALWAYS use only batteries with sealed caps over cells.

NEVER smoke while servicing batteries.

NEVER charge batteries near flammable materials.

NEVER allow batteries to overcharge and boil.

NEVER short across battery posts to check for current. NEVER break a live circuit at the battery.

NEVER disconnect battery from charger while charger is connected to a live power source.

NEVER jumpstart other vehicles using the boom lift batteries.

DAMAGED EQUIPMENT POLICY

Safety Statement

At Haulotte Group | BilJax, we are dedicated to the safety of all users of our products. All Haulotte Group | BilJax lifts are designed, manufactured and tested to comply with current applicable federal OSHA and ANSI codes and regulations.

Damage Policy

There may be occasions when a Haulotte Group | BilJax lift is involved in an incident that results in structural damage to the lift. Such damage can seriously compromise the ability of the lift to perform in a safe manner. Therefore, whenever a Haulotte Group | BilJax lift is damaged structurally or when there is suspected internal damage to the structure, Haulotte Group | BilJax may require that the lift be returned to our facility for reconditioning. For any questions concerning structural damage or the Damaged Equipment Policy, please contact the Haulotte Group | BilJax Service Department at 800-537-0540.

DAMAGED EQUIPMENT POLICY (Continued)

Damage Repair Notice

There may be occasions when a Haulotte Group | BilJax lift is involved in an accident resulting in damage to non-structural components. When such damage occurs and repairs are made by the owner or area distributor, please notify Haulotte Group | BilJax of these non-maintenance repairs and request a repair form to be filled out and returned to Haulotte Group | BilJax.

2 SPECIFICATIONS

Haulotte Group | BilJax, is dedicated to the continuous improvement of this and all Haulotte Group | BilJax products. Therefore, equipment information is subject to change without notice.

The following information is based on ideal working conditions. Machine performance may vary based on work environment and on machine options.

Direct any questions or concerns regarding equipment specifications to your regional Haulotte Group | BilJax representative or to the Haulotte Group | BilJax Service Department.

RANGE OF MOTION

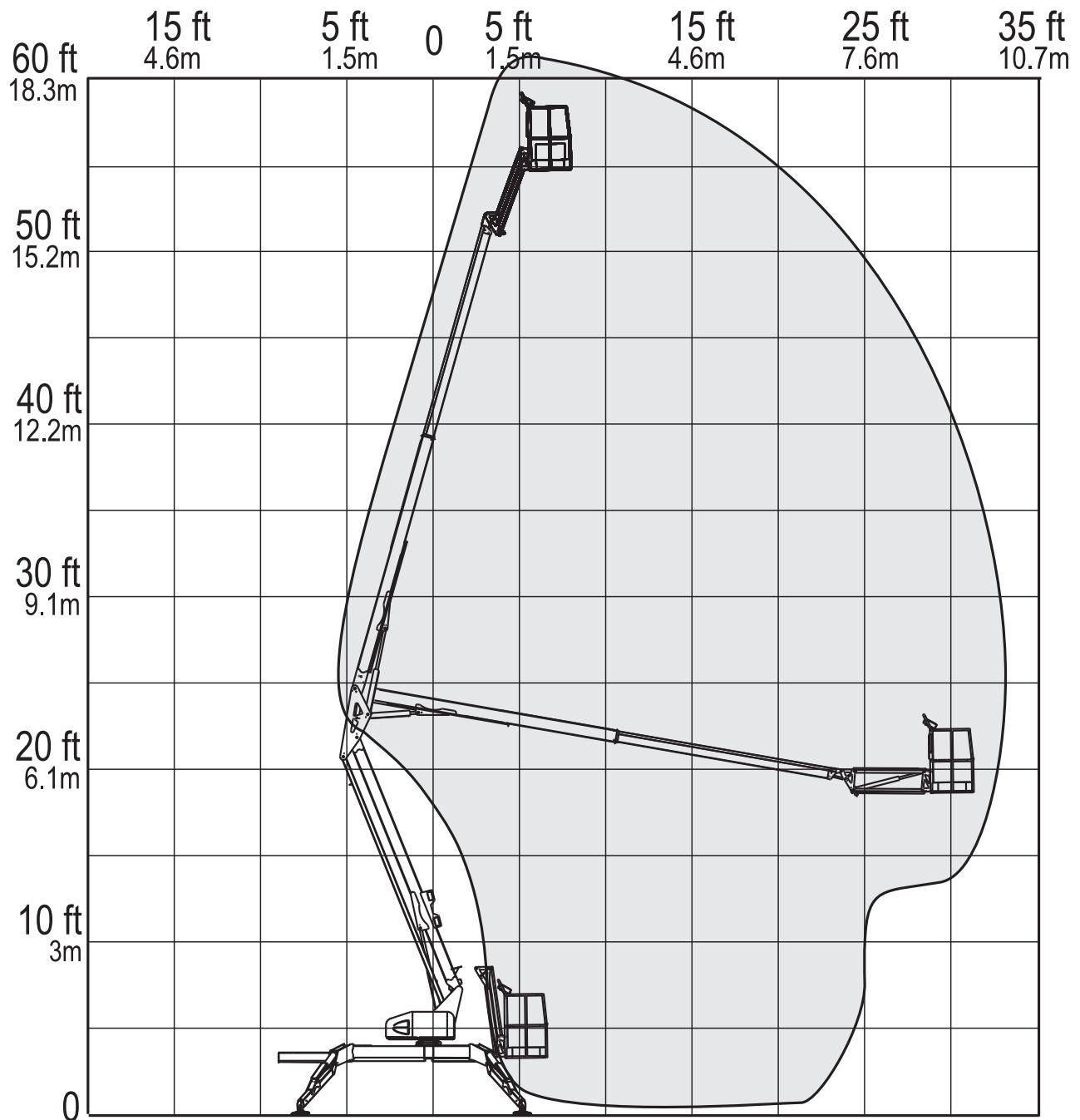

Figure 2-1 Range of Motion

SPECIFICATIONS

Serial Number _____

Maximum Working Height	61 ft 3 in (18.8 m)
Maximum Platform Height	55 ft 3 in (16.8 m)
Maximum Horizontal Outreach	
From Centerline	33 ft 5 in (10.2 m)
From Outrigger Footpad Edge	27 ft 4 in (8.2 m)
Rated Platform Capacity	
Without Platform Rotation	500 lb (227 kg)
With Platform Rotation	440 lb (200 kg)
Maximum Occupants	2
Total Weight	
No Options	6,200 lb (2,818 kg)
All Options	6,350 lb (2,881 kg)
Turntable Rotation	700° Non-Continuous
Leveling Capability	12.5°
Gradeability	
Gas Power	45%
DC Power	10%
Wheel Base	10 ft 1 in (3.1 m)
Inside Turning Radius	
2 Wheel Steering	11 ft (3.4 m)
4 Wheel Steering	6 ft 10 in (2.1 m)
Platform Dimensions	
Height	3 ft 7 in (1.1 m)
Length	2 ft 6 in (0.8 m)
Width – US / CE	5 ft (1.5 m) / 4 ft (1.2 m)
Stowed Dimensions	
Height	6 ft 10 in (2.1 m)
Length	21 ft 2 in (6.5 m)
Width	5 ft 8 in (1.7 m)
Outrigger Footprint (To Center of Pad)	
Length	13 ft 11 in (4.2 m)
Width	12 ft 9 in (3.9 m)
Footpad Diameter	12.5 in (0.3 m)
Parking Brake	Spring Applied / Hydraulically Released
Tire Size (Standard)	26 x 12 Bar lug tires
Control System	24V DC

Battery		4 x 6V 245 amp-hr
Charger		
Standard		110 Volt 60 Hz
CE		220 Volt 50 Hz
Hydraulic Pressure		3,000 PSI (20,684 kPa)
Reservoir Capacity		5.6 Gallons (21.2 L)
Hydraulic System Capacity		8.5 Gallons (32.2 L)
Hydraulic Oil (Standard)		AW46
Gas Engine		Kubota
Maximum Decibel Level		
DC Mode – Ground		60 dBA
DC Mode – Platform		55 dBA
Engine Mode – Ground		85 dBA
Engine Mode – Platform		80 dBA
Drive Speed		
	Gas Power	4.5 mph (7.2 km/hr)
	DC Power	2.5 mph (4.0 km/hr)
Function Speeds		
Boom Raise (Fast)		30-35 Seconds
Boom Raise (Slow)		50-55 Seconds
Boom Lower (Fast)		45-50 Seconds
Boom Lower (Slow)		120-150 Seconds
Boom Extend (Fast)		30-35 Seconds
Boom Extend (Slow)		75-90 Seconds
Boom Retract (Fast)		40-45 Seconds
Boom Retract (Slow)		100-110 Seconds
Turntable Rotation (Fast)		82-90 Seconds
Turntable Rotation (Slow)		240-270 Seconds
Platform Level (Fast)		8-10 Seconds
Platform Level (Slow)		12-16 Seconds
Outrigger Extend		15-20 Seconds
Outrigger Retract		25-30 Seconds
Localized Pressure per Outrigger		25 PSI (1.8 kg/cm ²) (176.5 kPa)
Max. Pressure per Tire – Floor Loading		35 PSI (2.5 kg/cm ²) (241.3 kPa)
Operation Temperature Range		-20° to 110° Fahrenheit (-29° to 43° Celsius)

WARRANTY

Haulotte Group | BilJax, warrants this product for one year, beginning on the date of delivery, to be free from defects of material and workmanship provided the unit is operated and maintained in compliance with the guidelines established in the Operations and Maintenance Manuals. Major structural components, including trailer tongue and boom weldments, are warranted for five years against defects due to material or workmanship. Haulotte Group | BilJax will, at its option, repair or replace any unit or component part that fails to function properly during normal use.

The warranty does not apply if the lift and/or its components have been altered, changed, or repaired without the consent of Haulotte Group | BilJax. Repairs, damage, or defects resulting from the following are not covered under the terms of the warranty: negligence, misuse, accidental damage, inadequate or improper maintenance, acts of nature, damage caused by chemicals or abrasive materials, and normal wear and tear, such as rust or corrosion. Components not covered under this warranty include tires, filters, covers, and routine maintenance items. Components not manufactured by Haulotte Group | BilJax are covered by their respective manufacturer's warranties. A list of those components and their warranties is available upon written request to Haulotte Group | BilJax.

Haulotte Group | BilJax shall not in any event be liable for the cost of any special, indirect, or consequential damages to any person, product, or thing. Haulotte Group | BilJax's maximum liability under this warranty is limited to the amount paid to Haulotte Group | BilJax for the product. This warranty is in lieu of all other warranties expressed or implied. Haulotte Group | BilJax neither assumes nor authorizes any or other entity to assume on its behalf any other liability in connection with the sale, rental, or use of this product.

Warranty Claims Process

In order to qualify for warranty coverage, the following conditions must be met:

- 1) Return of completed "Warranty Registration" form to Haulotte Group | BilJax within 15 days of receipt of product;
- 2) Notification to Haulotte Group | BilJax within 72 hours of any claimed defect, injury, or damage resulting from the claimed the defect; and
- 3) Warranty is limited to parts that are determined to be defective. This does not include parts worn out due to normal use.

Haulotte Group | BilJax authorized dealers or distributors are responsible for filing claims under warranty. Listed below is the warranty claims procedure.

- 1) Contact Haulotte Group | BilJax Service Department at 800-537-0540 to report the claim and verify warranty coverage. Machine serial number must be provided.
- 2) Identify the components to be claimed under warranty along with description of failure. A Returned Merchandise Authorization (RMA) number will be issued by Haulotte Group | BilJax.
- 3) Replacement parts will then be sent by Haulotte Group | BilJax to the dealer or distributor. All parts are invoiced at dealer/distributor list price. Credits will be issued when defective parts are returned to Haulotte Group | BilJax and found to be defective under warranty.
- 4) After completing repairs, submit warranty claim form and defective parts to Haulotte Group | BilJax. Warranty claim form and parts must be received within 30 days of claim in order to be eligible for credit. RMA number must be referenced on warranty claim form. Returned parts are to be sent prepaid and will be credited when part is received and verified. Warranty labor rate will be paid at current rate set by Haulotte Group | BilJax. The amount of labor hours reimbursed will be determined by Haulotte Group | BilJax and will be limited to 4 hours unless approved by Haulotte Group | BilJax.

Failure to follow the warranty claims process may result in delay in processing claim or denial of the claim. Haulotte Group | BilJax reserves the right to limit or adjust warranty claims with regard to parts, labor and travel time. Components purchased from suppliers other than Haulotte Group | BilJax are not covered under the terms of this warranty.

3 EQUIPMENT MAINTENANCE

Performing the appropriate maintenance procedures will extend the life of the boom lift and will help ensure the safety of personnel operating the equipment.

Repair, replacement or adjustment of any hydraulic or electrical control device should be performed only by fully trained and authorized personnel. These include, but are not limited to, hydraulic load valves, hydraulic flow control valves, solenoid valves and limit switches. These are safety related controls. Improper adjustment or tampering with these devices may impair boom lift function and result in safety or damage hazards.

Persons performing maintenance or repairs on the machine, including weld repairs, should be trained in accordance with the manufacturer's recommendations. Contact your regional Haulotte Group | BilJax representative if additional information is needed.

Critical or suspect areas identified during any scheduled inspection of the machine shall be examined by qualified personnel in accordance with applicable government regulations.

Never operate the machine if a defect or malfunction is identified or suspected. All defects and malfunctions must be repaired, and all maintenance performed, before returning a machine to service.

This manual contains a list of recommended maintenance procedures to be performed daily, weekly, monthly and annually.

It is the practice of Haulotte Group | BilJax to issue Service and/or Safety Bulletins, which may include updates to the information contained in this manual. In such instances, procedures contained in Haulotte Group | BilJax Service Bulletins or Safety Bulletins supersede the information contained in manuals.

Always follow maintenance schedule, regardless of use.

DAILY SERVICE CHECKS

The following Maintenance Procedures should be performed daily or before each operation.

Verify that all decals are correctly applied and in plain view.

- Refer to Section 5 for decal locations.

Verify that all controls and indicators at ground and platform control stations operate properly.

- Lower outriggers to level the boom lift.
- Raise and extend all booms.
- Press emergency STOP button.
- Verify that booms remain elevated and do not drift.
- Pull out STOP button and lower the booms.
- If either control station is unresponsive, refer to Table 3-2 for troubleshooting procedures.
- If display panel displays an error code, refer to Table 3-3 for error code definitions.

Verify operation of running and brake lights.

Verify correct tire inflation.

- Check sidewall of tires for inflation pressure (PSI / kPa)

Inspect tires for loose, damaged or missing lug nuts.

- Tighten or replace as necessary.

Inspect structural components and platform for obvious damage or debris.

- Repair or replace as necessary.

Inspect machine for missing, loose or damaged fasteners, including pins and bolts.

Verify that boom down limit switches operate correctly.

- Down limit switches are actuated when the boom is in a fully lowered, stowed position. Limit switches must be operational to raise or lower outriggers.
- If outrigger controls are unresponsive when boom is fully lowered and stowed, inspect down limit switches for loose mounting or visible damage.
- Repair or replace as needed.

Verify that outrigger safety interlocks operate correctly.

- Begin with the outriggers fully extended and the boom lift level. Raise one outrigger until the footpad is not in contact with the ground.
- Verify that boom functions are unresponsive when one outrigger is raised.
- Repeat this procedure for each outrigger.
- Raise all outriggers until the footpads are not in contact with the ground. Verify that all outrigger status LEDs on the ground control panel are unlit.
- Lower one outrigger until the footpad makes contact with the ground and the outrigger begins lifting the trailer.
- If the LED is lit before the footpad makes contact with the ground or if the LED remains unlit after the weight is transferred to the outrigger, the position switch or wiring is faulty.
- Repeat this procedure for each outrigger.
- Repair or replace as needed. Refer to Figure 3-1.

DAILY SERVICE CHECKS (Continued)

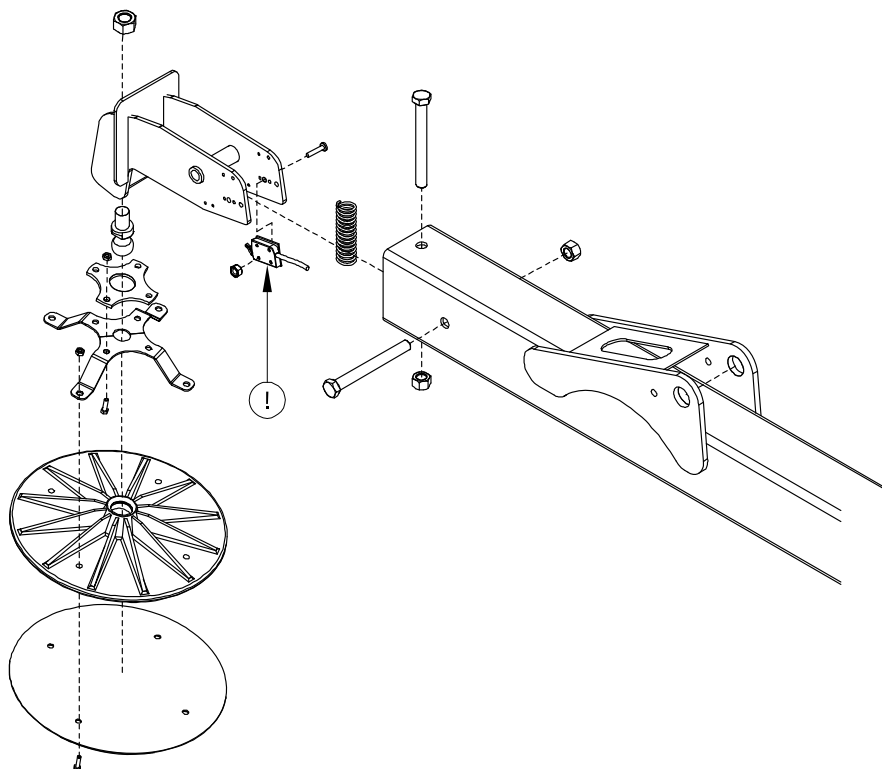

Figure 3-1 Outrigger Position Switches

Inspect hydraulic system and fluid levels

- Check all hydraulic hoses and fittings for leaks and damage. Tighten or replace as necessary to prevent hydraulic oil or pressure loss.
- The hydraulic oil level should be checked with the booms down, all outriggers raised and the trailer wheels on a level surface.
- Hydraulic oil level should be visible in, but not above, the sight gauge.
- If the hydraulic oil level is not visible to at least half way up the sight gauge (Figure 3-2), add clean hydraulic oil as necessary while all booms and outriggers are fully retracted and stowed. Pour slowly to avoid creating air pockets in the reservoir. Do not fill above sight gauge. Overfilling the hydraulic reservoir may cause damage to hydraulic lines and may result in equipment malfunction.

NOTICE

Do not mix hydraulic oils. Do not add any fluid to the hydraulic system that is not expressly recommended by the manufacturer. Adding unauthorized fluids to the hydraulic system may cause damage to equipment.

- The hydraulic reservoir is originally filled with AW46 hydraulic oil.
- Manufacturer recommends a higher viscosity hydraulic oil when operating equipment routinely in extreme climates.

DAILY SERVICE CHECKS (Continued)

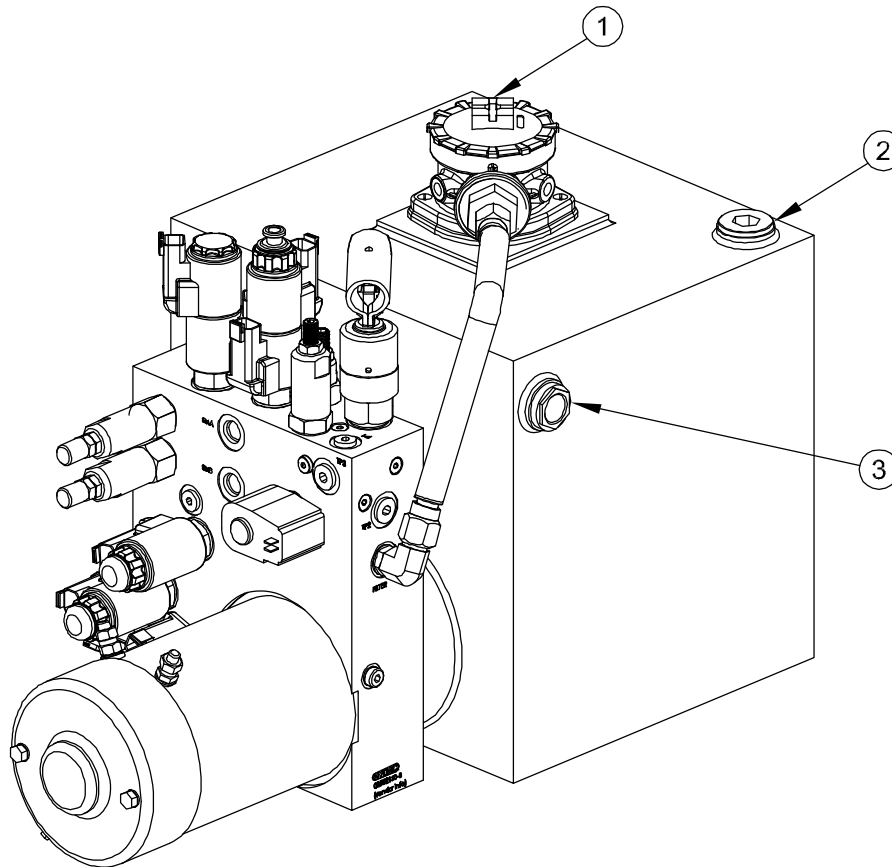

1. Filter Element
2. Fill Port
3. Sight Guage

Figure 3-2 Hydraulic Reservoir

WEEKLY SERVICE CHECKS

Perform the following service checks at least once each week in addition to all recommended Daily Service Checks:

Check Battery electrolyte level.

- If battery charge is low, add enough water to bring the electrolyte level to the top of the plates.
- If batteries are fully charged, raise electrolyte level to full mark in each cell.

Inspect all electrical wiring.

- Check for cuts, loose terminals, broken wires, chaffing and corrosion.
- Repair all damage, remove corrosion and seal exposed connections.

Inspect boom lift for missing, loose or damaged hardware.

- Repair or replace as necessary.

Inspect all hydraulic system components including pump and motor and cylinders for damage, leaks, loss of pressure or speed, and unusual noise or vibration.

- Repair or replace as necessary.

MONTHLY SERVICE CHECKS

Perform the following service checks at least once each month:

Clean all battery terminals.

Check battery for loose connections or damaged wires.

Verify proper operation of manual lowering valves and hand pump

- Refer to following pages for manual boom operating procedures.

Lubricate all compartment hinges and latches, slew ring and mating gear.

- Use NLGI Grade 2 multi-purpose grease.

Check wheel nut torque.

- Refer to Figure 3-3 for correct wheel nut tightening sequence.
- Evenly tighten wheel nuts to 25 lb-ft (34 N-M) in the tightening sequence shown.
- Repeat sequence, tightening wheel nuts to 60 lb-ft (81 N-M) and to 100 lb-ft (136 N-M).

NOTE: When wheels are newly installed or replaced, verify wheel nut torque monthly. Follow this procedure each time the wheel is removed and reinstalled.

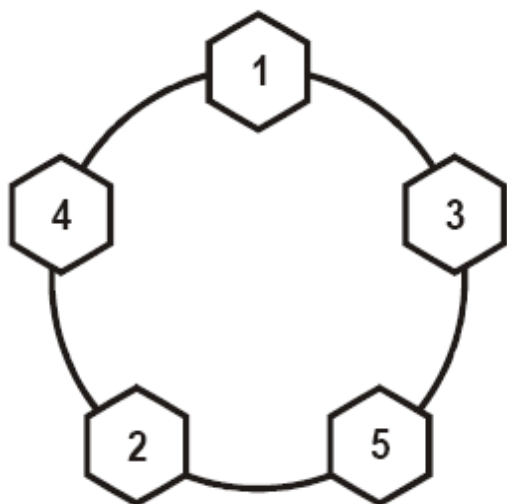

Figure 3-3 Wheel Nut Tightening Sequence

ANNUAL SERVICE CHECKS

Perform the following service checks at least once each year:

Replace Hydraulic Oil and Oil Filter.

- Drain hydraulic reservoir, clean and replace oil.
- Wipe away dirt and excess oil from around filter using cleaning cloths and alcohol solvent.
- Loosen and remove filter. Use absorbent cloths to keep excess oil from leaking onto the machine. Discard used filter.
- Wipe away dirt and excess oil from around filter housing.
- Install new filter. Do not over-tighten.
- With the fill port cap on but not tightened, completely raise and lower all booms to bleed trapped air from the lift cylinders. Repeat as necessary.
- Replace yearly, or whenever filter or oil contamination has a noticeable effect on boom functions.

ANNUAL SERVICE CHECKS (Continued)

Inspect pivot pins and cylinders, including rod ends, for wear or damage. Replace as necessary.

Visually inspect welds and structural components for wear, damage and corrosion.

- Follow all manufacturer's recommendations when making repairs to critical components.
- Personnel making repairs to welds should be certified in accordance with applicable government regulations.

Inspect outriggers for wear or damage. Repair or replace as necessary.

Verify that Level Sensor is operating correctly.

- Fully deploy outriggers until all Outrigger LEDs and auto level LED are lit, and buzzer sounds.
- Verify that machine is level, and that level sensor is giving an accurate reading.
- Repair or replace as necessary.

Inspect and adjust axle and parking brakes.

Load test boom lift operations with 500 lbs (187 kg) load.

Check slew bearing for wear or damage.

- Check bolts for wear or damage.
- With the boom lift fully retracted, measure the distance between the slew ring gear and the horizontal plate above. Use a 2-inch (50 mm) caliper or bore micrometer. Record the measurement (Figure 3-4).
- Place a 175 lb (65 kg) load on the boom lift platform.
- Measure the distance between the slew ring and the horizontal plate above. Record the measurement.
- If the difference in measurements is greater than 0.25 in (6.35 mm) the slew ring bearing should be replaced. Contact manufacturer for replacement instructions and assistance.

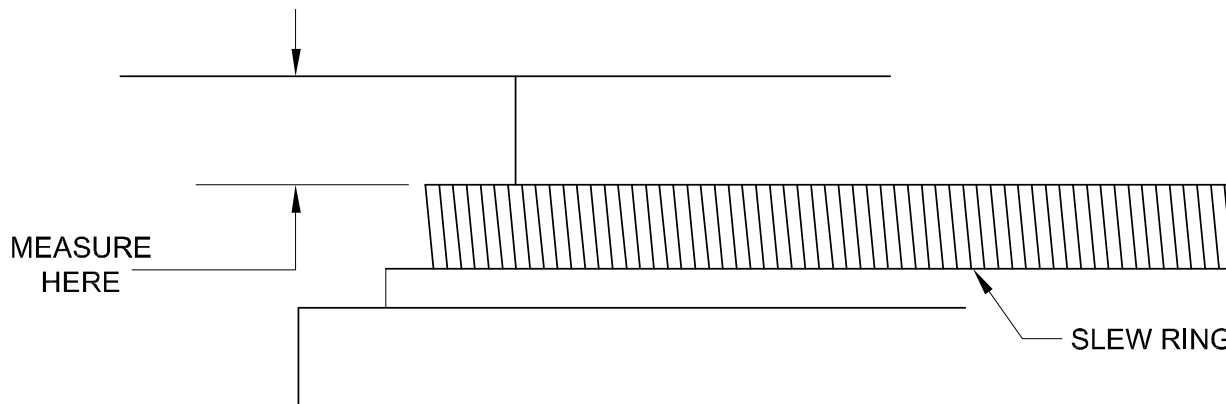

Figure 3-4 Slew Ring Position Measurement

STRUCTURAL INSPECTION

A comprehensive structural inspection of the unit shall be performed under any of the following conditions:

- Ten years from the date of manufacture and every five years thereafter.
- After any actual, suspected or potential damage is sustained that could affect the structural integrity or stability of the aerial platform.
- After a change in ownership. Owners should provide a complete service history when reselling the unit.

The structural inspection shall include the following considerations:

- The service history of the unit, including hours of service, work performed and environmental conditions.
- The inspection and maintenance record of the unit.
- The effectiveness of all controls and components.
- A visual inspection of the unit for wear or damage.

STRUCTURAL INSPECTION (Continued)

- Manufacturer recommendations.
- A visual weld inspection, to be performed by qualified personnel in accordance with applicable government regulations.

ADDITIONAL SERVICE INFORMATION

Seals on hydraulic cylinders should be replaced every five years or as indicated by machine performance.

All service checks should be performed on a machine that has been stored without use for a period exceeding thirty days.

Check for air in the hydraulic system if the machine has been stored without use for a period exceeding thirty days, or if the machine was stored without use during a seasonal climate change. Air trapped in the hydraulic system will affect machine performance. Follow procedures for bleeding air from the hydraulic system, found in Section 4.

Owners and lessors should complete a full inspection of all components and perform a test of all functions, including brake functions, before commissioning or reselling machine. Always repair or replace all damaged or malfunctioning components before commissioning or reselling machine.

When a change in ownership occurs, it is the responsibility of the seller to provide the new owner with all manuals for the machine. It is the responsibility of the buyer to notify the manufacturer of the unit model and serial number and the name and address of the new owner within 60 days.

Use the Service Checklists found at the back of this Manual to record all Service Checks as well as any maintenance, repairs or alterations performed on the machine.

Records of frequent safety checks need not be made. However, where a safety hazard is found, it shall be reported in writing to the owner of the machine, and a record of any corrective action shall be maintained for five years or as required by the authority having jurisdiction.

Testing Machine Stability

The aerial work platform has been tested for stability using a load equal to 150% of the rated capacity of the machine and placed at the center of the platform with the boom fully extended. Stability tests should be conducted only by trained personnel and only when the machine is properly anchored to safeguard against tipping.

BATTERY RECHARGE

Recharge boom lift batteries after each 8-hour work shift or as needed. When boom lift is not in use, batteries should be recharged at least once per week. Under normal circumstances, battery recharge should take approximately 10-12 hours. However, a full recharge may take up to 24 hours, if the battery charge is extremely low.

WARNING

Recharge batteries in a well-ventilated area only. Do not charge batteries near fire, spark or other potential ignition sources. Batteries may emit highly explosive hydrogen gas while charging. Failure to properly ventilate the charge gases may result in serious injury or death. Always charge boom lift batteries away from flammable materials

To recharge the boom lift batteries:

- Move the boom lift to a well-ventilated area with direct access to 120 VAC electrical outlet. Keep the boom lift and batteries away from open flame or other potential ignition sources.
- Attach a 12 AWG multi-strand, grounded extension cord with a maximum length of 50 feet (15 meters) to the receptacle located on the cargo plate in front of the turntable

NOTE: Using an underrated or long power cord will reduce the output of the battery charger and may extend charge time.

BATTERY RECHARGE (Continued)

- Plug the extension cord into a grounded 120 VAC outlet. Verify that the green CHARGING indicator LED is lit on the battery charger faceplate (Figure 3-5).

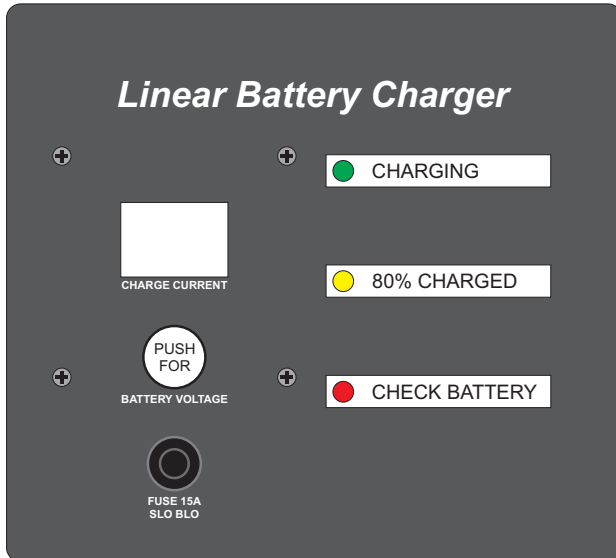

Figure 3-5 Battery Charger Faceplate

- The CHARGING indicator LED remains lit continuously during the first stage of the charge cycle. The bulk mode CHARGE CURRENT will be displayed on the battery charger faceplate.
- Press and hold the BATTERY VOLTAGE button to display the detected battery voltage.
- If a battery fault is detected, the appropriate fault code will appear on the CHARGE CURRENT display. The red CHECK BATTERY indicator LED will become lit. See Table 3-1 for battery charger fault codes.

WARNING

Do not disconnect any output leads or connectors between the batteries and the charger when the charger is on. To stop a charge in progress, always unplug the extension cord from the AC power source.

- When the battery charge reaches 80% of capacity, the yellow 80% CHARGED indicator LED will become lit and the green CHARGING indicator LED will begin to flash.
- When the batteries have reached a full charge, the green and yellow indicator LEDs will turn themselves off. CC (Charge Complete) will appear on the CHARGE CURRENT display. After two hours, this display will fade and the CHARGE CURRENT will read 00.
- Unplug the extension cord from the 120 VAC outlet and the charger receptacle on the boom lift. Store the extension cord for next use.

WARNING

Always unplug the battery charger power cord before moving the boom lift. Failure to disconnect power cord will cause damage to the equipment.

CHARGER FAULT CODES**Table 3-1 Charger Fault Codes**

Code	Description	Limits	Cause
F0	No Battery	<10 volts	Loose connection or battery missing
F1	Over Voltage	>112% charge voltage	Connected to wrong battery voltage
F2	Over Current	>60 amperes	Operating machine while charging
F3	Bulk Mode Timeout	<80% charge at 16 hrs.	Battery fault
F4	ARD Mode Timeout	>80% and <full charge after 6 hrs Max.	Battery fault
F9	Current Measurement Error Standby		Board fault or charger exposed to extreme cold
FA	Triac Error		Board shorted
FF	Full Power to Transformer, No Current Output		Battery shorted or low AC line voltage or charge fault
CO	Charger Off		Charger resting between pulses (AGM batteries only)
CC	Charge Mode Complete		Batteries charged

MANUAL BOOM OPERATION

Manual retraction, rotation and lowering functions allow the aerial work platform to be moved and lowered during hydraulic power interruption or failure. In each instance, refer to Figure-3-7.

The following procedures for manual retraction, rotation and lowering require a person on the ground to operate the manual controls and hand pump.

The hydraulic hand pump is located in the pump compartment. In case of a power failure, the hand pump and selected hydraulic valve settings can be used to manually retract the Telescoping boom or rotate the boom turntable.

To begin manual retraction or rotation, turn Proportional Valve (item 2) counterclockwise until it stops, and insert pump handle into the pump handle fitting.

Manual Retraction

Pushing and holding the Retract button (item 4) simultaneously actuating Hand Pump (item 1) will retract the extension boom section.

Manual Rotation

To rotate the turntable clockwise: Push and hold the Rotation button (item 3) and simultaneously actuate Hand Pump (item 1).

To rotate the turntable counterclockwise: Pull the Rotation button (item 3) out and simultaneously actuate Hand Pump (item 1).

NOTE: Return proportional valve (item 2) to its original position before lowering the lift or resuming normal operation.

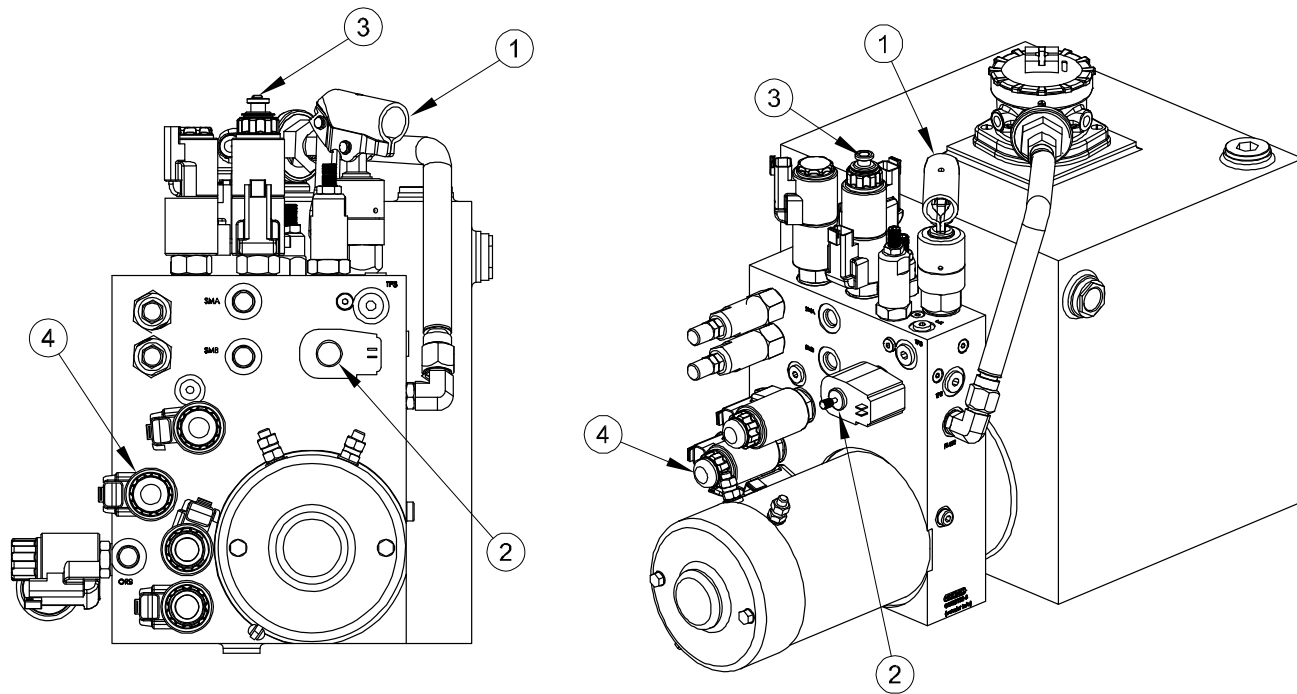

- | | |
|-----------------------|--------------------|
| 1. Hand Pump | 3. Rotation Button |
| 2. Proportional Valve | 4. Retract Button |

Figure 3-6 Hand Pump and Controls for Manual Lift Operation

Manual Lowering

The Manual Lowering Valves are equipped with a plunger, found at the base of each cylinder (Figure 3-7). Depress the plunger to lower the boom sections in case of a complete electrical power failure, a load shift, or other emergency.

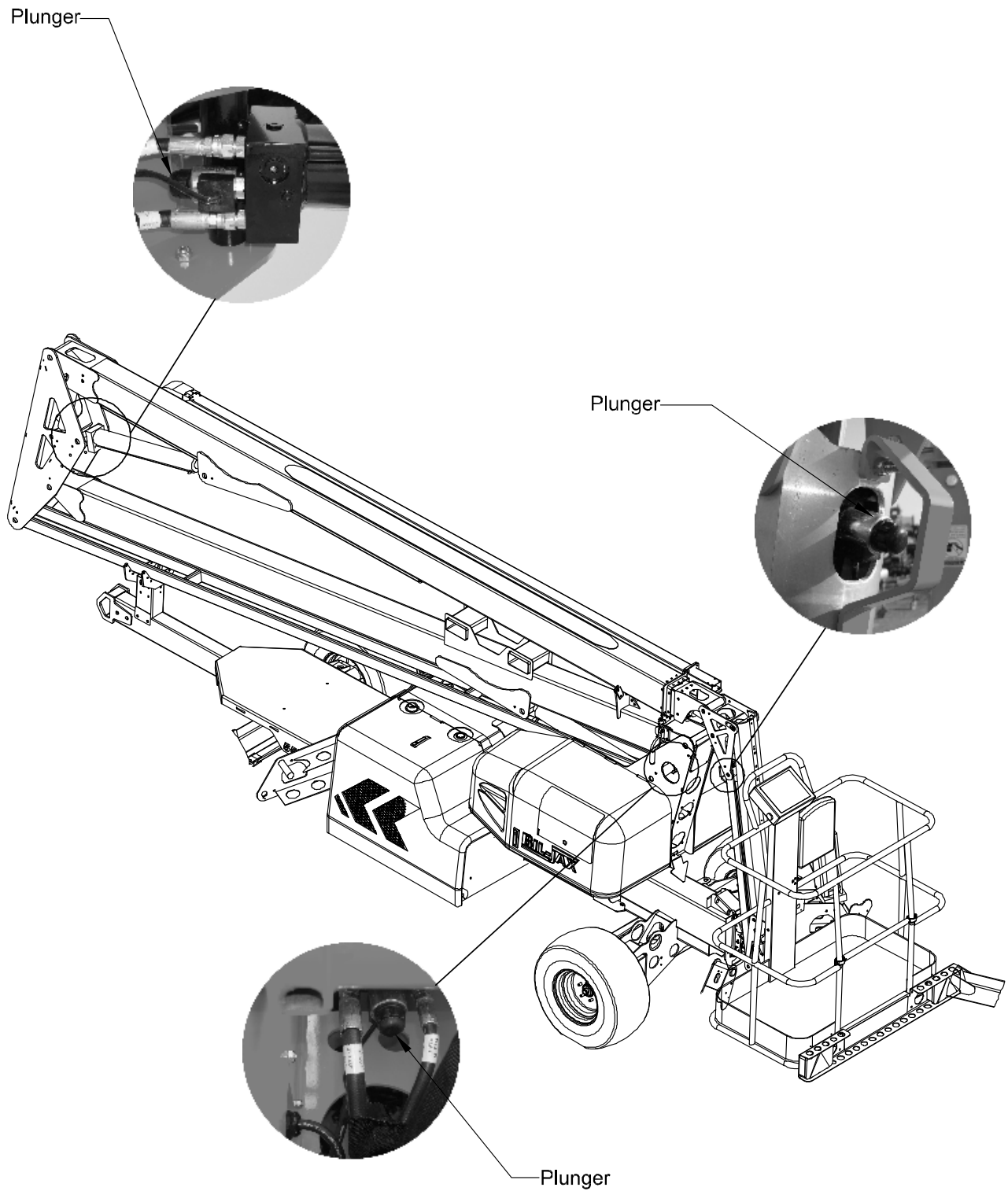

Figure 3-7 Manual Lowering Valve

TROUBLESHOOTING

Refer to Table 3-2 for basic troubleshooting operations. Additional information can be found in the Haulotte Group | BilJax Model 55XA Operator's Manual. Contact the Haulotte Group | BilJax Service Department with any questions or before attempting any advanced troubleshooting operations.

Table 3-2 Troubleshooting Steps

PROBLEM	CAUSE	SOLUTION
No lights on panel when key switch is turned to the on position.	a. Emergency STOP engaged.	a. Disengage Emergency stop buttons.
	b. Battery charge is low.	b. Recharge as needed.
	c. Battery ground or in-series cable is loose.	c. Inspect and repair battery connections.
	d. Battery main disconnect unplugged.	d. Plug in main disconnect.
	e. Blown fuse.	e. Replace fuse as necessary.
Hydraulic function does not work and display window shows an error message	a. Fault detected by safety interlock microprocessor.	a. Refer to Table 3-3 for error code definition and correction.
	b. Boom Lift electric or electronic failure	b. Refer to Table 3-3 for error code definition and correction.
Outrigger indicator LED lights do not function.	a. Key switch turned to the OFF or platform controls position.	a. Turn key switch to ground controls position.
	b. Emergency STOP engaged.	b. Disengage emergency STOP buttons.
	c. Outriggers not deployed.	c. Deploy all outriggers.
One or more boom controls do not function OR One or more boom controls function improperly OR One or more boom controls function intermittently.	a. Key switch is turned to the OFF or incorrect control position.	a. Turn key switch to ground or platform controls position.
	b. Battery charge is low.	b. Recharge battery.
	c. Emergency STOP engaged.	c. Disengage Emergency STOP buttons.
	d. Battery ground or in-series cable loose.	d. Inspect and repair battery connections.
	e. All outriggers not properly deployed.	e. Deploy all outriggers and level boom lift.
	f. Hydraulic pump inoperative.	f. Inspect pump; replace or repair as needed.
	g. Loose wiring connector.	g. Check wiring terminals in control box and at valve manifold; replace or repair as needed.
	h. Valve solenoid not operating properly.	h. Clean valve solenoid and recheck function(s); replace or repair as needed.
	i. Fault detected by system interlock.	i. Check display for system status. Refer to Table 3-3 for error code definitions and correction.
	j. Broken or loose wire.	j. Inspect wiring in control box and at valve manifold and valve coil; repair or replace as needed.

ERROR CODE DEFINITIONS

The DISPLAY PANEL located on the ground control panel indicates the present operating status of the boom lift. If an error condition is detected by the control processor during start-up or operation, the appropriate error code will be displayed on this panel.

Refer to Table 3-3 for a comprehensive list of Error Code Definitions and solutions.

Table 3-3 Error Code Definitions

ERROR MESSAGE	ERROR DEFINITION	TO SIMULATE ERROR	TO CLEAR ERROR	COMMENTS
001 MACHINE IS IN DOWN ONLY MODE	Machine went out of level with use, moment sense or load sense circuits have detected an overload	Level machine, raise boom and tilt level sensor	This is a self clearing error. When error condition is corrected, error is cleared	Error will be displayed only if boom is raised
002 LOSS OF PLATFORM COMMUNICATION	Lower Control has lost RS485 communication with Platform Control	Open Platform Control and remove green wire from J1	This is a latched error. Power must be cycled to clear error	The Platform Control "Engine On" LED will also blink a 2 blink error code.
003 LOSS OF DRIVE COMMUNICATION	Lower Control has lost RS485 communication with Drive Control	Open Drive Control and remove green wire from J1	This is a latched error. Power must be cycled to clear error	Machines with Drive option only. The Drive Control "Engine On" LED will also blink a 2 blink error code.
004 LOSS OF PC COMMUNICATION	Lower Control has lost RS232 communication with PC	Connect a PC without running the configuration program	This is a self clearing error. When error condition is corrected, error is cleared	Error message will only be display if connected to a PC that is not communicating.
005 PLATFORM CONTROL HAS STUCK KEY	Platform Control has detected a stuck or pressed key on power up	On Platform Control hold down a key at power up	This is a latched error. Power must be cycled to clear error	The Platform Control "Engine On" LED will also blink a 1 blink error code.
006 DRIVE CONTROL HAS STUCK KEY	Drive Control has detected a stuck or pressed key on power up	On Drive Control hold down a key at power up	This is a latched error. Power must be cycled to clear error	Machines with Drive option only.. The Drive Control "Engine On" LED will also blink a 1 blink error code.
007 DRIVE CONTROL HAS STUCK JOYSTICK	Drive Control has detected a stuck or pressed joystick on power up	On Drive Control hold joystick to side at power up	This is a latched error. Power must be cycled to clear error	Machines with Drive option only. The Drive Control "Engine On" LED will also blink a 3 blink error code.
008 GROUND CONTROL HAS STUCK KEY	Lower Control has detected a stuck or pressed key on power up	On Lower Control hold down a key at power up	This is a latched error. Power must be cycled to clear error	The Lower Control "Power" LED will also blink a 1 blink error code.
009 BOOM UP WITHOUT OUTRIGGERS ON GROUND	Lower Control has detected the boom is up and all four outriggers are not on the ground	Disconnect a wire from either the boom down or any outrigger switch and turn on machine	This is a self clearing error. When error condition is corrected, error is cleared	
010 LEVEL SENSOR HAS ERRATIC OUTPUT	The Lower Control has detected an erratic output from the level sensor	Shaking the level sensor after machine has been leveled	This is a self clearing error. When error condition is corrected, error is cleared	This error is suppressed during extending and retracting outriggers
011 TRYING TO DRIVE W/ TRAILER BRAKE OFF	An attempt was made to drive machine without engaging the trailer brake	Trying to drive machine with trailer brake off	This is a self clearing error. When error condition is corrected, error is cleared	Machines with Drive and Set option only
012 ANGLE SENSOR IS DISCONNECTED OR BAD	Angle sensor output is out of range	Disconnect Angle Sensor	This is a self clearing error. When error condition is corrected, error is cleared	Machines with Moment Sense option only

ERROR MESSAGE	ERROR DEFINITION	TO SIMULATE ERROR	TO CLEAR ERROR	COMMENTS
013 PRESSURE SENSOR IS DISCONNECTED OR BAD	Pressure sensor output is out of range	Disconnect Pressure Sensor	This is a self clearing error. When error condition is corrected, error is cleared	Machines with Moment Sense option only
014 CHECK ENGINE LOW OIL PRESSURE	Engine had low oil pressure while running	Kawasaki Engine: While engine is running, disconnect engine oil pressure sense wire Kubota Engine: While engine is running, disconnect engine oil pressure sense wire and connect wire to ground	This is a latched error. Power must be cycled to clear error	X-Boom Machines with Kawasaki or Kubota engines
015 MACHINE IS NOT LEVEL	Machine has gone out of level with use	Tilt level sensor	This is a self clearing error. When error condition is corrected, error is cleared	
016 LIFT BOOM	A Boom Rotate, Extend or Retract function has been requested while boom is down	Try to Rotate, Extend or Retract the boom while boom is down	This is a self clearing error. When error condition is corrected, error is cleared	
017 STOW BOOM	An Outrigger function has been requested while boom is up	Try to move an outrigger while boom is up	This is a self clearing error. When error condition is corrected, error is cleared	
018 LOSS OF LOAD SENSE COMMUNICATION	Lower Control has lost RS485 communication with Load Sense Module	Remove Load Sense Module from machine	This is a latched error. Power must be cycled to clear error	Machines with Load Sense option only
019 BOOM FUNCTION DISABLED	Load Sense Module has detected an overloaded boom and disabled boom functions	Overload Boom	This is a latched error. Power must be cycled to clear error	Machines with Load Sense option only
020 LOSS OF LOAD CELL CONNECTION	Load Sense Module has lost connection with Load Cell	Disconnect Load Cell from Load Sense Module	This is a self clearing error. When error condition is corrected, error is cleared	Machines with Load Sense option only
021 OPEN CIRCUIT PRIMARY UP	A load of less than 70mA was detected when Primary Up circuit was energized	Disconnect a wire from Primary Up coil	This is a latched error. Power must be cycled to clear error	Checked only at power up
022 SHORTED CIRCUIT PRIMARY UP	Excessive load was detected when Primary Up circuit was energized	Use a piece of wire to short the Primary Up coil	This is a latched error. Power must be cycled to clear error	Checked only at power up
023 OPEN CIRCUIT PRIMARY DOWN	A load of less than 70mA was detected when Primary Down circuit was energized	Disconnect a wire from Primary Down coil	This is a latched error. Power must be cycled to clear error	Checked only at power up Articulating Boom Models
024 SHORTED CIRCUIT PRIMARY DOWN	Excessive load was detected when Primary Down circuit was energized	Use a piece of wire to short the Primary Down coil	This is a latched error. Power must be cycled to clear error	Checked only at power up Articulating Boom Models
025 OPEN CIRCUIT SECONDARY UP	A load of less than 70mA was detected when Secondary Up circuit was energized	Disconnect a wire from Secondary Up coil	This is a latched error. Power must be cycled to clear error	Checked only at power up Articulating Boom Models
026 SHORTED CIRCUIT SECONDARY UP	Excessive load was detected when Secondary Up circuit was energized	Use a piece of wire to short the Secondary Up coil	This is a latched error. Power must be cycled to clear error	Checked only at power up Articulating Boom Models
027 OPEN CIRCUIT SECONDARY DOWN	A load of less than 70mA was detected when Secondary Down circuit was energized	Disconnect a wire from Secondary Down coil	This is a latched error. Power must be cycled to clear error	Checked only at power up Articulating Boom Models

ERROR MESSAGE	ERROR DEFINITION	TO SIMULATE ERROR	TO CLEAR ERROR	COMMENTS
028 SHORTED CIRCUIT SECONDARY DOWN	Excessive load was detected when Secondary Down circuit was energized	Use a piece of wire to short the Secondary Down coil	This is a latched error. Power must be cycled to clear error	Checked only at power up Articulating Boom Models
029 OPEN CIRCUIT JIB UP	A load of less than 70mA was detected when Jib Up circuit was energized	Disconnect a wire from Jib Up coil	This is a latched error. Power must be cycled to clear error	Checked only at power up Articulating Boom Models
030 SHORTED CIRCUIT JIB UP	Excessive load was detected when Jib Up circuit was energized	Use a piece of wire to short the Jib Up coil	This is a latched error. Power must be cycled to clear error	Checked only at power up Articulating Boom Models
031 OPEN CIRCUIT JIB DOWN	A load of less than 70mA was detected when Jib Down circuit was energized	Disconnect a wire from Jib Down coil	This is a latched error. Power must be cycled to clear error	Checked only at power up Articulating Boom Models
032 SHORTED CIRCUIT JIB DOWN	Excessive load was detected when Jib Down circuit was energized	Use a piece of wire to short the Jib Down coil	This is a latched error. Power must be cycled to clear error	Checked only at power up Articulating Boom Models
033 OPEN CIRCUIT EXTEND	A load of less than 70mA was detected when Extend circuit was energized	Disconnect a wire from Extend coil	This is a latched error. Power must be cycled to clear error	Checked only at power up
034 SHORTED CIRCUIT EXTEND	Excessive load was detected when Extend circuit was energized	Use a piece of wire to short the Extend coil	This is a latched error. Power must be cycled to clear error	Checked only at power up
035 OPEN CIRCUIT RETRACT	A load of less than 70mA was detected when Retract circuit was energized	Disconnect a wire from Retract coil	This is a latched error. Power must be cycled to clear error	Checked only at power up
036 SHORTED CIRCUIT RETRACT	Excessive load was detected when Retract circuit was energized	Use a piece of wire to short the Retract coil	This is a latched error. Power must be cycled to clear error	Checked only at power up
037 OPEN CIRCUIT PLATFORM LEVEL UP	A load of less than 70mA was detected when Platform Level Up circuit was energized	Disconnect a wire from Platform Level Up coil	This is a latched error. Power must be cycled to clear error	Checked only at power up
038 SHORTED CIRCUIT PLATFORM LEVEL UP	Excessive load was detected when Platform Level Up circuit was energized	Use a piece of wire to short the Platform Level Up coil	This is a latched error. Power must be cycled to clear error	Checked only at power up
039 OPEN CIRCUIT PLATFORM LEVEL DOWN	A load of less than 70mA was detected when Platform Level Down circuit was energized	Disconnect a wire from Platform Level Down coil	This is a latched error. Power must be cycled to clear error	Checked only at power up
040 SHORTED CIRCUIT PLATFORM LEVEL DOWN	Excessive load was detected when Platform Level Down circuit was energized	Use a piece of wire to short the Platform Level Down coil	This is a latched error. Power must be cycled to clear error	Checked only at power up
041 OPEN CIRCUIT PLATFORM CW	A load of less than 70mA was detected when Platform CW circuit was energized	Disconnect a wire from Platform CW coil	This is a latched error. Power must be cycled to clear error	Checked only at power up Articulating Boom Models
042 SHORTED CIRCUIT PLATFORM CW	Excessive load was detected when Platform CW circuit was energized	Use a piece of wire to short the Platform CW coil	This is a latched error. Power must be cycled to clear error	Checked only at power up Articulating Boom Models
043 OPEN CIRCUIT PLATFORM CCW	A load of less than 70mA was detected when Platform CCW circuit was energized	Disconnect a wire from Platform CCW coil	This is a latched error. Power must be cycled to clear error	Checked only at power up Articulating Boom Models

ERROR MESSAGE	ERROR DEFINITION	TO SIMULATE ERROR	TO CLEAR ERROR	COMMENTS
044 SHORTED CIRCUIT PLATFORM CCW	Excessive load was detected when Platform CCW circuit was energized	Use a piece of wire to short the Platform CCW coil	This is a latched error. Power must be cycled to clear error	Checked only at power up Articulating Boom Models
045 OPEN CIRCUIT TURNTABLE CW	A load of less than 70mA was detected when Turntable CW circuit was energized	Disconnect a wire from Turntable CW coil	This is a latched error. Power must be cycled to clear error	Checked only at power up
046 SHORTED CIRCUIT TURNTABLE CW	Excessive load was detected when Turntable CW circuit was energized	Use a piece of wire to short the Turntable CW coil	This is a latched error. Power must be cycled to clear error	Checked only at power up
047 OPEN CIRCUIT TURNTABLE CCW	A load of less than 70mA was detected when Turntable CCW circuit was energized	Disconnect a wire from Turntable CCW coil	This is a latched error. Power must be cycled to clear error	Checked only at power up
048 SHORTED CIRCUIT TURNTABLE CCW	Excessive load was detected when Turntable CCW circuit was energized	Use a piece of wire to short the Turntable CCW coil	This is a latched error. Power must be cycled to clear error	Checked only at power up
049 OPEN CIRCUIT OUTRIGGER RETRACT	A load of less than 70mA was detected when Outrigger Retract circuit was energized	Disconnect a wire from Outrigger Retract coil	This is a latched error. Power must be cycled to clear error	Checked only at power up
050 SHORTED CIRCUIT OUTRIGGER RETRACT	Excessive load was detected when Outrigger Retract circuit was energized	Use a piece of wire to short the Outrigger Retract coil	This is a latched error. Power must be cycled to clear error	Checked only at power up
051 OPEN CIRCUIT OUTRIGGER EXTEND	A load of less than 70mA was detected when Outrigger Extend circuit was energized	Disconnect a wire from Outrigger Extend coil	This is a latched error. Power must be cycled to clear error	Checked only at power up
052 SHORTED CIRCUIT OUTRIGGER EXTEND	Excessive load was detected when Outrigger Extend circuit was energized	Use a piece of wire to short the Outrigger Extend coil	This is a latched error. Power must be cycled to clear error	Checked only at power up
053 OPEN CIRCUIT LF OUTRIGGER	A load of less than 70mA was detected when LF Outrigger circuit was energized	Disconnect a wire from LF Outrigger coil	This is a latched error. Power must be cycled to clear error	Checked only at power up
054 SHORTED CIRCUIT LF OUTRIGGER	Excessive load was detected when LF Outrigger circuit was energized	Use a piece of wire to short the LF Outrigger coil	This is a latched error. Power must be cycled to clear error	Checked only at power up
055 OPEN CIRCUIT RF OUTRIGGER	A load of less than 70mA was detected when RF Outrigger circuit was energized	Disconnect a wire from RF Outrigger coil	This is a latched error. Power must be cycled to clear error	Checked only at power up
056 SHORTED CIRCUIT RF OUTRIGGER	Excessive load was detected when RF Outrigger circuit was energized	Use a piece of wire to short the RF Outrigger coil	This is a latched error. Power must be cycled to clear error	Checked only at power up
057 OPEN CIRCUIT LR OUTRIGGER	A load of less than 70mA was detected when LR Outrigger circuit was energized	Disconnect a wire from LR Outrigger coil	This is a latched error. Power must be cycled to clear error	Checked only at power up
058 SHORTED CIRCUIT LR OUTRIGGER	Excessive load was detected when LR Outrigger circuit was energized	Use a piece of wire to short the LR Outrigger coil	This is a latched error. Power must be cycled to clear error	Checked only at power up

ERROR MESSAGE	ERROR DEFINITION	TO SIMULATE ERROR	TO CLEAR ERROR	COMMENTS
059 OPEN CIRCUIT RR OUTRIGGER	A load of less than 70mA was detected when RR Outrigger circuit was energized	Disconnect a wire from RR Outrigger coil	This is a latched error. Power must be cycled to clear error	Checked only at power up
060 SHORTED CIRCUIT RR OUTRIGGER	Excessive load was detected when RR Outrigger circuit was energized	Use a piece of wire to short the RR Outrigger coil	This is a latched error. Power must be cycled to clear error	Checked only at power up
061 OPEN CIRCUIT ENGINE THROTTLE	A load of less than 70mA was detected when Engine Throttle circuit was energized	Disconnect a wire from Engine Throttle coil	This is a latched error. Power must be cycled to clear error	Error Suppressed due to low current draw
062 SHORTED CIRCUIT ENGINE THROTTLE	Excessive load was detected when Engine Throttle circuit was energized	Use a piece of wire to short the Engine Throttle coil	This is a latched error. Power must be cycled to clear error	Error Suppressed due to low current draw
063 OPEN CIRCUIT ENGINE STARTER	A load of less than 70mA was detected when Engine Starter circuit was energized	Disconnect a wire from Engine Starter coil	This is a latched error. Power must be cycled to clear error	Not Tested, Do not want to crank engine on power up
064 SHORTED CIRCUIT ENGINE STARTER	Excessive load was detected when Engine Starter circuit was energized	Use a piece of wire to short the Engine Starter coil	This is a latched error. Power must be cycled to clear error	Not Tested, Do not want to crank engine on power up
065 OPEN CIRCUIT ENGINE CHOKE	A load of less than 70mA was detected when Engine Choke circuit was energized	Disconnect a wire from Engine Choke coil	This is a latched error. Power must be cycled to clear error	Error Suppressed due to low current draw
066 SHORTED CIRCUIT ENGINE CHOKE	Excessive load was detected when Engine Choke circuit was energized	Use a piece of wire to short the Engine Choke coil	This is a latched error. Power must be cycled to clear error	Error Suppressed due to low current draw
067 OPEN CIRCUIT ENGINE STOP	A load of less than 70mA was detected when Engine Stop circuit was energized	Disconnect a wire from Engine Stop coil	This is a latched error. Power must be cycled to clear error	Error Suppressed due to low current draw
068 SHORTED CIRCUIT ENGINE STOP	Excessive load was detected when Engine Stop circuit was energized	Use a piece of wire to short the Engine Stop coil	This is a latched error. Power must be cycled to clear error	Error Suppressed due to low current draw
069 OPEN CIRCUIT PROPORTION-AL	A load of less than 70mA was detected when Proportional circuit was energized	Disconnect a wire from Proportional coil	This is a latched error. Power must be cycled to clear error	Checked only at power up
070 SHORTED CIRCUIT PROPORTIONAL	Excessive load was detected when Proportional circuit was energized	Use a piece of wire to short the Proportional coil	This is a latched error. Power must be cycled to clear error	Checked only at power up
071 OPEN CIRCUIT MOTOR CONTROL ENABLE	A load of less than 70mA was detected when Motor Control Enable circuit was energized	Disconnect a wire from Motor Control Enable coil		Error Suppressed due to low current draw
072 SHORTED CIRCUIT MOTOR CONTROL ENABLE	Excessive load was detected when Motor Control Enable circuit was energized	Use a piece of wire to short the Motor Control Enable coil		Error Suppressed due to low current draw
073 OPEN CIRCUIT SPARE OUTPUT	A load of less than 70mA was detected when Spare Output circuit was energized	Disconnect a wire from Spare Output coil	This is a latched error. Power must be cycled to clear error	Not Used

ERROR MESSAGE	ERROR DEFINITION	TO SIMULATE ERROR	TO CLEAR ERROR	COMMENTS
074 SHORTED CIRCUIT SPARE OUTPUT	Excessive load was detected when Spare Output circuit was energized	Use a piece of wire to short the Spare Output coil	This is a latched error. Power must be cycled to clear error	Not Used
075 OPEN CIRCUIT AC SWITCH	A load of less than 70mA was detected when AC Switch circuit was energized	Disconnect a wire from AC Switch coil		Error Suppressed due to low current draw
076 SHORTED CIRCUIT AC SWITCH	Excessive load was detected when AC Switch circuit was energized	Use a piece of wire to short the AC Switch coil		Error Suppressed due to low current draw
077 OPEN CIRCUIT STROBE	A load of less than 70mA was detected when Strobe circuit was energized	Disconnect a wire from Strobe		Error Suppressed due to low current draw
078 SHORTED CIRCUIT STROBE	Excessive load was detected when Strobe circuit was energized	Use a piece of wire to short the Strobe coil		Error Suppressed due to low current draw
079 OPEN CIRCUIT DRIVE PWM	A load of less than 70mA was detected when Drive PWM circuit was energized	Disconnect a wire from Drive PWM coil	This is a latched error. Power must be cycled to clear error	Checked only at power up Machines with Drive option only
080 SHORTED CIRCUIT DRIVE PWM	Excessive load was detected when Drive PWM circuit was energized	Use a piece of wire to short the Drive PWM coil	This is a latched error. Power must be cycled to clear error	Checked only at power up Machines with Drive option only
081 OPEN CIRCUIT DRIVE ENABLE	A load of less than 70mA was detected when Drive Enable circuit was energized	Disconnect a wire from Drive Enable coil	This is a latched error. Power must be cycled to clear error	Checked only at power up Machines with Drive option only
082 SHORTED CIRCUIT DRIVE ENABLE	Excessive load was detected when Drive Enable circuit was energized	Use a piece of wire to short the Drive Enable coil	This is a latched error. Power must be cycled to clear error	Checked only at power up Machines with Drive option only
083 OPEN CIRCUIT DRIVE DUMP (C21)	A load of less than 70mA was detected when Drive Dump (C21) circuit was energized	Disconnect a wire from Drive Dump (C21) coil	This is a latched error. Power must be cycled to clear error	Checked only at power up Machines with 4WD option only
084 SHORTED CIRCUIT DRIVE DUMP (C21)	Excessive load was detected when Drive Dump (C21) circuit was energized	Use a piece of wire to short the Drive Engage coil	This is a latched error. Power must be cycled to clear error	Checked only at power up Machines with 4WD option only
085 OPEN CIRCUIT TURN LEFT (C22)	A load of less than 70mA was detected when Turn Left (C22) circuit was energized	Disconnect a wire from Turn Left (C22) coil	This is a latched error. Power must be cycled to clear error	Checked only at power up Machines with 4WD option only
086 SHORTED CIRCUIT TURN LEFT (C22)	Excessive load was detected when Turn Left (C22) circuit was energized	Use a piece of wire to short the Turn Left (C22) coil	This is a latched error. Power must be cycled to clear error	Checked only at power up Machines with 4WD option only
087 OPEN CIRCUIT TURN RIGHT (C23)	A load of less than 70mA was detected when Turn Right (C23) circuit was energized	Disconnect a wire from Turn Right (C23) coil	This is a latched error. Power must be cycled to clear error	Checked only at power up Machines with 4WD option only
088 SHORTED CIRCUIT TURN RIGHT (C23)	Excessive load was detected when Turn Right (C23) circuit was energized	Use a piece of wire to short the Turn Right (C23) coil	This is a latched error. Power must be cycled to clear error	Checked only at power up Machines with 4WD option only
089 OPEN CIRCUIT FORWARD 1 (C24)	A load of less than 70mA was detected when Forward 1 (C24) circuit was energized	Disconnect a wire from Forward 1 (C24) coil	This is a latched error. Power must be cycled to clear error	Checked only at power up Machines with 4WD option only

ERROR MESSAGE	ERROR DEFINITION	TO SIMULATE ERROR	TO CLEAR ERROR	COMMENTS
090 SHORTED CIRCUIT FORWARD 1 (C24)	Excessive load was detected when Forward 1 (C24) circuit was energized	Use a piece of wire to short the Forward 1 (C24) coil	This is a latched error. Power must be cycled to clear error	Checked only at power up Machines with 4WD option only
091 OPEN CIRCUIT REVERSE 1 (C25)	A load of less than 70mA was detected when Reverse 1 (C25) circuit was energized	Disconnect a wire from Reverse 1 (C25) coil	This is a latched error. Power must be cycled to clear error	Checked only at power up Machines with 4WD option only
092 SHORTED CIRCUIT REVERSE 1 (C25)	Excessive load was detected when Reverse 1 (C25) circuit was energized	Use a piece of wire to short the Reverse 1 (C25) coil	This is a latched error. Power must be cycled to clear error	Checked only at power up Machines with 4WD option only
093 OPEN CIRCUIT FORWARD 2 (C27)	A load of less than 70mA was detected when Forward 2 (C27) circuit was energized	Disconnect a wire from Forward 2 (C27) coil	This is a latched error. Power must be cycled to clear error	Checked only at power up Machines with 4WD option only
094 SHORTED CIRCUIT FORWARD 2 (C27)	Excessive load was detected when Forward 2 (C27) circuit was energized	Use a piece of wire to short the Forward 2 (C27) coil	This is a latched error. Power must be cycled to clear error	Checked only at power up Machines with 4WD option only
095 OPEN CIRCUIT REVERSE 2 (C28)	A load of less than 70mA was detected when Reverse 2 (C28) circuit was energized	Disconnect a wire from Reverse 2 (C28) coil	This is a latched error. Power must be cycled to clear error	Checked only at power up Machines with 4WD option only
096 SHORTED CIRCUIT REVERSE 2 (C28)	Excessive load was detected when Reverse 2 (C28) circuit was energized	Use a piece of wire to short the Reverse 2 (C28) coil	This is a latched error. Power must be cycled to clear error	Checked only at power up Machines with 4WD option only
097 OPEN CIRCUIT TORQUE H/L (C29)	A load of less than 70mA was detected when Torque H/L (C29) circuit was energized	Disconnect a wire from Torque H/L (C29) coil	This is a latched error. Power must be cycled to clear error	Checked only at power up Machines with 4WD option only
098 SHORTED CIRCUIT TORQUE H/L (C29)	Excessive load was detected when Torque H/L (C29) circuit was energized	Use a piece of wire to short the Torque H/L (C29) coil	This is a latched error. Power must be cycled to clear error	Checked only at power up Machines with 4WD option only
099 OPEN CIRCUIT TORQUE H/L (C30)	A load of less than 70mA was detected when Torque H/L (C30) circuit was energized	Disconnect a wire from Torque H/L (C30) coil	This is a latched error. Power must be cycled to clear error	Checked only at power up Machines with 4WD option only
100 SHORTED CIRCUIT TORQUE H/L (C30)	Excessive load was detected when Torque H/L (C30) circuit was energized	Use a piece of wire to short the Torque H/L (C30) coil	This is a latched error. Power must be cycled to clear error	Checked only at power up Machines with 4WD option only
101 OPEN CIRCUIT TORQUE H/L (C31)	A load of less than 70mA was detected when Torque H/L (C31) circuit was energized	Disconnect a wire from Torque H/L (C31) coil	This is a latched error. Power must be cycled to clear error	Checked only at power up Machines with 4WD option only
102 SHORTED CIRCUIT TORQUE H/L (C31)	Excessive load was detected when Torque H/L (C31) circuit was energized	Use a piece of wire to short the Torque H/L (C31) coil	This is a latched error. Power must be cycled to clear error	Checked only at power up Machines with 4WD option only
103 OUTREACH NEAR MAXIMUM	Boom has exceeded 95% of maximum outreach	Put 500lbs in boom, level boom and extend until alarm sounds and error is displayed	This is a self clearing error. When error condition is corrected, error is cleared	Machines with Moment Sense option only
104 OUTREACH AT MAXIMUM	Boom has reached maximum outreach setting	Put 500lbs in boom, level boom and extend until alarm sounds and error is displayed	This is a self clearing error. When error condition is corrected, error is cleared	Machines with Moment Sense option only

ERROR MESSAGE	ERROR DEFINITION	TO SIMULATE ERROR	TO CLEAR ERROR	COMMENTS
105 OVER MAXIMUM CYLINDER PRESSURE	Cylinder pressure has exceeded maximum pressure setting	Put 500lbs in boom, lower cylinder pressure setting using configuration program and extend boom until alarm sounds and error is displayed	This is a latched error. Power must be cycled to clear error	Machines with Moment Sense option only
106 OUTREACH SENSING FAULT	Cylinder safety pressure switch has detected maximum pressure setting	Disconnect safety pressure switch wires	This is a latched error. Power must be cycled to clear error	Machines with Moment Sense option only
107 ENGINE TEMP HIGH CHECK WATER LEVEL	Excessive engine temperature was detected	Remove wire from engine temperature sensor and connect wire to ground	This is a self clearing error. When error condition is corrected, error is cleared	Machines with 4WS option only
108 CHECK ALTERNATOR NOT CHARGING	Engine alternator is not charging	Remove P wire from alternator and connect wire to ground	This is a self clearing error. When error condition is corrected, error is cleared	Machines with 4WS option only
109 ENGINE RPM FAULT HIGH RPM IS TOO LOW	When driving, engine high RPM was too low	Misadjust engine high RPM to a value less than 3000 RPM and attempt to drive	This is a latched error. Power or engine must be cycled to clear error	Machines with 4WS option only
121 OPEN CIRCUIT BRAKE (FWS C21)	A load of less than 70mA was detected when Brake (FWS C21) circuit was energized	Disconnect a wire from Brake (FWS C21) coil	This is a latched error. Power must be cycled to clear error	Checked only at power up Machines with 4WS option only
122 SHORTED CIRCUIT BRAKE (FWS C21)	Excessive load was detected when Brake (FWS C21) circuit was energized	Use a piece of wire to short the Brake (FWS C21) coil	This is a latched error. Power must be cycled to clear error	Checked only at power up Machines with 4WS option only
123 OPEN CIRCUIT RS RET (FWS C22)	A load of less than 70mA was detected when RS Ret (FWS C22) circuit was energized	Disconnect a wire from RS Ret (FWS C22) coil	This is a latched error. Power must be cycled to clear error	Checked only at power up Machines with 4WS option only
124 SHORTED CIRCUIT RS RET (FWS C22)	Excessive load was detected when RS Ret (FWS C22) circuit was energized	Use a piece of wire to short the RS Ret (FWS C22) coil	This is a latched error. Power must be cycled to clear error	Checked only at power up Machines with 4WS option only
125 OPEN CIRCUIT RS EXT (FWS C23)	A load of less than 70mA was detected when RS Ext (FWS C23) circuit was energized	Disconnect a wire from RS Ext (FWS C23) coil	This is a latched error. Power must be cycled to clear error	Checked only at power up Machines with 4WS option only
126 SHORTED CIRCUIT RS EXT (FWS C23)	Excessive load was detected when RS Ext (FWS C23) circuit was energized	Use a piece of wire to short the RS Ext (FWS C23) coil	This is a latched error. Power must be cycled to clear error	Checked only at power up Machines with 4WS option only
127 OPEN CIRCUIT FS RET (FWS C24)	A load of less than 70mA was detected when FS Ret (FWS C24) circuit was energized	Disconnect a wire from FS Ret (FWS C24) coil	This is a latched error. Power must be cycled to clear error	Checked only at power up Machines with 4WS option only
128 SHORTED CIRCUIT FS RET (FWS C24)	Excessive load was detected when FS Ret (FWS C24) circuit was energized	Use a piece of wire to short the FS Ret (FWS C24) coil	This is a latched error. Power must be cycled to clear error	Checked only at power up Machines with 4WS option only
129 OPEN CIRCUIT FS EXT (FWS C25)	A load of less than 70mA was detected when FS Ext (FWS C25) circuit was energized	Disconnect a wire from FS Ext (FWS C25) coil	This is a latched error. Power must be cycled to clear error	Checked only at power up Machines with 4WS option only
130 SHORTED CIRCUIT FS EXT (FWS C25)	Excessive load was detected when FS Ext (FWS C25) circuit was energized	Use a piece of wire to short the FS Ext (FWS C25) coil	This is a latched error. Power must be cycled to clear error	Checked only at power up Machines with 4WS option only

ERROR MESSAGE	ERROR DEFINITION	TO SIMULATE ERROR	TO CLEAR ERROR	COMMENTS
131 OPEN CIRCUIT DC D FWD (FWS C26)	A load of less than 70mA was detected when DC D Fwd (FWS C26) circuit was energized	Disconnect a wire from DC D Fwd (FWS C26) coil	This is a latched error. Power must be cycled to clear error	Checked only at power up Machines with 4WS option only
132 SHORTED CIRCUIT DC D FWD (FWS C26)	Excessive load was detected when DC D Fwd (FWS C26) circuit was energized	Use a piece of wire to short the DC D Fwd (FWS C26) coil	This is a latched error. Power must be cycled to clear error	Checked only at power up Machines with 4WS option only
133 OPEN CIRCUIT DC D REV (FWS C27)	A load of less than 70mA was detected when DC D Rev (FWS C27) circuit was energized	Disconnect a wire from DC D Rev (FWS C27) coil	This is a latched error. Power must be cycled to clear error	Checked only at power up Machines with 4WS option only
134 SHORTED CIRCUIT DC D REV (FWS C27)	Excessive load was detected when DC D Rev (FWS C27) circuit was energized	Use a piece of wire to short the DC D Rev (FWS C27) coil	This is a latched error. Power must be cycled to clear error	Checked only at power up Machines with 4WS option only
135 OPEN CIRCUIT DC D (FWS C28)	A load of less than 70mA was detected when DC D (FWS C28) circuit was energized	Disconnect a wire from DC D (FWS C28) coil	This is a latched error. Power must be cycled to clear error	Checked only at power up Machines with 4WS option only
136 SHORTED CIRCUIT DC D (FWS C28)	Excessive load was detected when DC D (FWS C28) circuit was energized	Use a piece of wire to short the DC D (FWS C28) coil	This is a latched error. Power must be cycled to clear error	Checked only at power up Machines with 4WS option only
137 OPEN CIRCUIT DC D (FWS C29)	A load of less than 70mA was detected when DC D (FWS C29) circuit was energized	Disconnect a wire from DC D (FWS C29) coil	This is a latched error. Power must be cycled to clear error	Checked only at power up Machines with 4WS option only
138 SHORTED CIRCUIT DC D (FWS C29)	Excessive load was detected when DC D (FWS C29) circuit was energized	Use a piece of wire to short the DC D (FWS C29) coil	This is a latched error. Power must be cycled to clear error	Checked only at power up Machines with 4WS option only
139 OPEN CIRCUIT DC D (FWS C30)	A load of less than 70mA was detected when DC D (FWS C30) circuit was energized	Disconnect a wire from DC D (FWS C30) coil	This is a latched error. Power must be cycled to clear error	Checked only at power up Machines with 4WS option only
140 SHORTED CIRCUIT DC D (FWS C30)	Excessive load was detected when DC D (FWS C30) circuit was energized	Use a piece of wire to short the DC D (FWS C30) coil	This is a latched error. Power must be cycled to clear error	Checked only at power up Machines with 4WS option only
141 OPEN CIRCUIT DC D (FWS C31)	A load of less than 70mA was detected when DC D (FWS C31) circuit was energized	Disconnect a wire from DC D (FWS C31) coil	This is a latched error. Power must be cycled to clear error	Checked only at power up Machines with 4WS option only
142 SHORTED CIRCUIT DC D (FWS C31)	Excessive load was detected when DC D (FWS C31) circuit was energized	Use a piece of wire to short the DC D (FWS C31) coil	This is a latched error. Power must be cycled to clear error	Checked only at power up Machines with 4WS option only
143 OPEN CIRCUIT (FWS C32)	A load of less than 70mA was detected when (FWS C32) circuit was energized	Disconnect a wire from (FWS C32) coil	This is a latched error. Power must be cycled to clear error	Checked only at power up Machines with 4WS option only
144 SHORTED CIRCUIT (FWS C32)	Excessive load was detected when (FWS C32) circuit was energized	Use a piece of wire to short the (FWS C32) coil	This is a latched error. Power must be cycled to clear error	Checked only at power up Machines with 4WS option only
145 OPEN CIRCUIT (FWS C33)	A load of less than 70mA was detected when (FWS C33) circuit was energized	Disconnect a wire from (FWS C33) coil	This is a latched error. Power must be cycled to clear error	Checked only at power up Machines with 4WS option only

ERROR MESSAGE	ERROR DEFINITION	TO SIMULATE ERROR	TO CLEAR ERROR	COMMENTS
146 SHORTED CIRCUIT (FWS C33)	Excessive load was detected when (FWS C33) circuit was energized	Use a piece of wire to short the (FWS C33) coil	This is a latched error. Power must be cycled to clear error	Checked only at power up Machines with 4WS option only
147 OPEN CIRCUIT (FWS C34)	A load of less than 70mA was detected when (FWS C34) circuit was energized	Disconnect a wire from (FWS C34) coil	This is a latched error. Power must be cycled to clear error	Checked only at power up Machines with 4WS option only
148 SHORTED CIRCUIT (FWS C34)	Excessive load was detected when (FWS C34) circuit was energized	Use a piece of wire to short the (FWS C34) coil	This is a latched error. Power must be cycled to clear error	Checked only at power up Machines with 4WS option only
149 OPEN CIRCUIT (FWS R2)	A load of less than 70mA was detected when (FWS R2) circuit was energized	Disconnect a wire from (FWS R2) coil	This is a latched error. Power must be cycled to clear error	Checked only at power up Machines with 4WS option only
150 SHORTED CIRCUIT (FWS R2)	Excessive load was detected when (FWS R2) circuit was energized	Use a piece of wire to short the (FWS R2) coil	This is a latched error. Power must be cycled to clear error	Checked only at power up Machines with 4WS option only
151 OPEN CIRCUIT (FWS GEN G1)	A load of less than 70mA was detected when (FWS Gen G1) circuit was energized	Disconnect a wire from (FWS Gen G1) coil	This is a latched error. Power must be cycled to clear error	Checked only at power up Machines with 4WS option only
152 SHORTED CIRCUIT (FWS GEN G1)	Excessive load was detected when (FWS Gen G1) circuit was energized	Use a piece of wire to short the (FWS Gen G1) coil	This is a latched error. Power must be cycled to clear error	Checked only at power up Machines with 4WS option only
153 OPEN CIRCUIT (FWS CON 24V)	A load of less than 70mA was detected when (FWS Con 24V) circuit was energized	Disconnect a wire from (FWS Con 24V) coil	This is a latched error. Power must be cycled to clear error	Checked only at power up Machines with 4WS option only
154 SHORTED CIRCUIT (FWS CON 24V)	Excessive load was detected when (FWS Con 24V) circuit was energized	Use a piece of wire to short the (FWS Con 24V) coil	This is a latched error. Power must be cycled to clear error	Checked only at power up Machines with 4WS option only
155 OPEN CIRCUIT (FWS SPARE 1)	A load of less than 70mA was detected when (FWS Spare 1) circuit was energized	Disconnect a wire from (FWS Spare 1) coil	This is a latched error. Power must be cycled to clear error	Checked only at power up Machines with 4WS option only
156 SHORTED CIRCUIT (FWS SPARE 1)	Excessive load was detected when (FWS Spare 1) circuit was energized	Use a piece of wire to short the (FWS Spare 1) coil	This is a latched error. Power must be cycled to clear error	Checked only at power up Machines with 4WS option only
157 OPEN CIRCUIT (FWS SPARE 2)	A load of less than 70mA was detected when (FWS Spare 2) circuit was energized	Disconnect a wire from (FWS Spare 2) coil	This is a latched error. Power must be cycled to clear error	Checked only at power up Machines with 4WS option only
158 SHORTED CIRCUIT (FWS SPARE 2)	Excessive load was detected when (FWS Spare 2) circuit was energized	Use a piece of wire to short the (FWS Spare 2) coil	This is a latched error. Power must be cycled to clear error	Checked only at power up Machines with 4WS option only
159 OPEN CIRCUIT (FWS SPARE 3)	A load of less than 70mA was detected when (FWS Spare 3) circuit was energized	Disconnect a wire from (FWS Spare 3) coil	This is a latched error. Power must be cycled to clear error	Checked only at power up Machines with 4WS option only
160 SHORTED CIRCUIT (FWS SPARE 3)	Excessive load was detected when (FWS Spare 3) circuit was energized	Use a piece of wire to short the (FWS Spare 3) coil	This is a latched error. Power must be cycled to clear error	Checked only at power up Machines with 4WS option only

ERROR MESSAGE	ERROR DEFINITION	TO SIMULATE ERROR	TO CLEAR ERROR	COMMENTS
161 OPEN CIRCUIT (FWS PROP A1)	A load of less than 70mA was detected when (FWS Prop A1) circuit was energized	Disconnect a wire from (FWS Prop A1) coil	This is a latched error. Power must be cycled to clear error	Checked only at power up Machines with 4WS option only
162 SHORTED CIRCUIT (FWS PROP A1)	Excessive load was detected when (FWS Prop A1) circuit was energized	Use a piece of wire to short the (FWS Prop A1) coil	This is a latched error. Power must be cycled to clear error	Checked only at power up Machines with 4WS option only
163 OPEN CIRCUIT (FWS PROP A2)	A load of less than 70mA was detected when (FWS Prop A2) circuit was energized	Disconnect a wire from (FWS Prop A2) coil	This is a latched error. Power must be cycled to clear error	Checked only at power up Machines with 4WS option only
164 SHORTED CIRCUIT (FWS PROP A2)	Excessive load was detected when (FWS Prop A2) circuit was energized	Use a piece of wire to short the (FWS Prop A2) coil	This is a latched error. Power must be cycled to clear error	Checked only at power up Machines with 4WS option only
165 OPEN CIRCUIT (FWS PROP B1)	A load of less than 70mA was detected when (FWS Prop B1) circuit was energized	Disconnect a wire from (FWS Prop B1) coil	This is a latched error. Power must be cycled to clear error	Checked only at power up Machines with 4WS option only
166 SHORTED CIRCUIT (FWS PROP B1)	Excessive load was detected when (FWS Prop B1) circuit was energized	Use a piece of wire to short the (FWS Prop B1) coil	This is a latched error. Power must be cycled to clear error	Checked only at power up Machines with 4WS option only
167 OPEN CIRCUIT (FWS PROP B2)	A load of less than 70mA was detected when (FWS Prop B2) circuit was energized	Disconnect a wire from (FWS Prop B2) coil	This is a latched error. Power must be cycled to clear error	Checked only at power up Machines with 4WS option only
168 SHORTED CIRCUIT (FWS PROP B2)	Excessive load was detected when (FWS Prop B2) circuit was energized	Use a piece of wire to short the (FWS Prop B2) coil	This is a latched error. Power must be cycled to clear error	Checked only at power up Machines with 4WS option only

MOTOR CONTROLLER FAULT CODE DEFINITIONS

The Motor Controllers, located under the left power compartment cover (behind lower control box), indicate the operating status of each motor controller. If an error condition is detected, the appropriate fault code will be displayed on the affected motor controller by a flashing indicator light (See Fig. 3-8).

Refer to Table 3-4 for a comprehensive list of Fault Code Definitions and solutions.

Table 3-4 Motor Controller Fault Code Definitions

FLASH FAULT	PRIORITY ID	FAULT	DESCRIPTION	SOLUTION
Steady ON, no flashing	1	None	System is operating normally.	None required.
1	11	Configuration Range Error	One or more controller personality settings are out of range.	Use Sevcon calibrator to enter correct settings from latest Personality Sheet.
1	12	CRC Error	The controller personality checksum is incorrect.	Use Sevcon calibrator to enter correct settings from latest Personality Sheet. Otherwise, replace motor controller.
2	5	Sequence Fault	Enable line is active at power up.	Check enable line, B- wiring, and Molex connector.
2	6	Accelerator Fault	Invalid accelerator personality setting.	Check speed input line, B- wiring, Molex connector, and 1000 ohm resistor.
3	17	MOSFET Short Circuit	MOSFET short circuit or controller miswire detected	Check for miswired B+, B-, or pump cables. Make sure pump terminals are not shorted to frame. If cables and pump are OK, then replace motor controller.
4	14	Line Contactor Welded	The line contactor is welded or otherwise shorted.	Check line contactor wiring. If wiring is OK, then replace line contactor.
4	15	Line Contactor did not Close	Line contactor did not close or is otherwise open circuit.	Check line contactor wiring and Molex connector. Measure the contactor coil resistance; it should be around 50 ohms. If contactor and wiring are OK, then replace motor controller.
5	16	Motor Open Circuit	Pump motor cable disconnected.	Check pump-motor and controller cables. Measure pump motor resistance it should be near zero ohms.
6	N/A	Not used in this application	N/A	N/A
7	7	Low Battery	Battery voltage is too low.	Recharge the batteries. Look for shorted battery cells. Make sure one or more batteries are not reversed.
7	8	High Battery	Battery voltage is too high.	Make sure battery charger is off. Check for poor or corroded battery connections.
7	10	High Battery with Line Contactor Open	High battery voltage was detected at power up before line contactor closed.	Make sure battery charger is off or that the battery is not overcharged.
8	1	Thermal Cutback	Maximum power available to motor has been reduced due to excessive heat sink temperature.	Remove power and allow controller to cool. If fault repeatedly occurs, look for binding on the hydraulic cylinders or sticking valves. Otherwise, the pump motor may be failing.
8	3	Pump I ² T Current Limit Cutback	Maximum power available to pump motor has been reduced by the Current Limit Cutback function.	Recycle power. If fault repeatedly occurs, look for binding on the hydraulic cylinders or sticking valves. Otherwise, the pump motor may be failing.
9	N/A	Not used in this application	N/A	N/A
10	N/A	Not used in this application	N/A	N/A
11	18	Autozero Out of Range	Internal pump current measurement circuit could not be calibrated.	Replace motor controller.

FLASH FAULT	PRIORITY ID	FAULT	DESCRIPTION	SOLUTION
11	24	System Monitor	Illegal system condition sensed due to internal hardware fault.	Replace motor controller.
Single flash, then off	19	MOSFETs Off	MOSFETs did not pulse when the internal failsafe circuit was enabled.	Check for reversed cables among B+, B-, and A terminals. If no miswire is found, replace motor controller.
Single flash, then off	20	MOSFETs On	MOSFETs pulsed while the internal failsafe circuit was disabled.	Check for reversed cables among B+, B-, and A terminals. If no miswire is found, replace motor controller.
Single flash, then off	22	Contactor Drive Off	Contactor output did not pulse with the internal failsafe circuit enabled.	Replace motor controller.
Single flash, then off	23	Contactor Drive On	Contactor output pulsed while the internal failsafe circuit was disabled.	Replace motor controller.

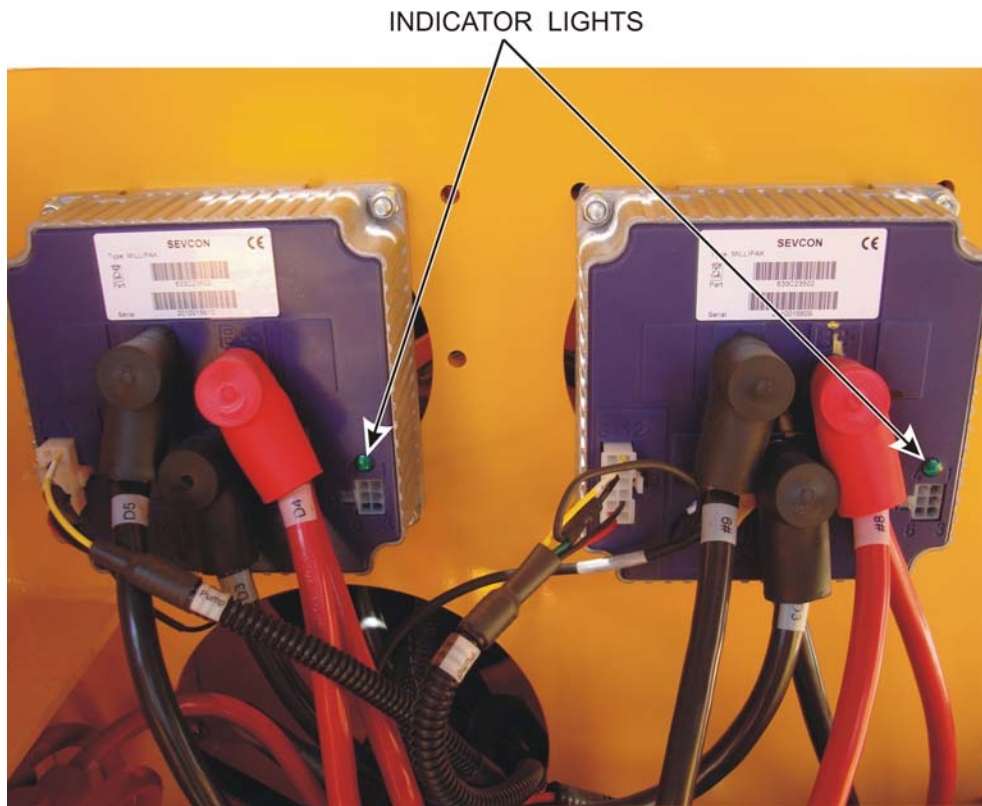

Figure 3-8 Motor Controllers

4 CYLINDER REPLACEMENT

If repair or replacement of a boom lift or outrigger hydraulic cylinder or its component parts becomes necessary, observe the following procedures in accordance with the safety precautions established in Section 1 of this manual.

Removing the hydraulic cylinder from the boom lift may require the use of specialized tools and lifting equipment. NEVER attempt to operate overhead hoists or cranes or related equipment without proper training, authorization and supervision. Perform all maintenance procedures only in an area that is well-lit and well-ventilated. Haulotte Group | BilJax, is not responsible for personal injury or property damage resulting from the improper use of equipment or failure to follow all procedures and related safety precautions.

Direct all questions regarding cylinder removal and replacement to the Haulotte Group | BilJax Service Department at 800-537-0540.

LIFT CYLINDER REPLACEMENT

Use the following procedure to remove and replace faulty or damaged hydraulic cylinders on the boom lift:

 **WARNING**

Repair and removal of the hydraulic cylinders requires the use of lifting straps and an overhead crane or lifting gear to support the boom lift and hydraulic cylinders. Personnel should be thoroughly trained in the operation of these devices before attempting installation or removal. Hydraulic cylinders are heavy and may have hydraulic oil on their surface. Failure to use proper equipment or to securely support boom and boom cylinders can result in damage to lift components, serious injury or death.

- Lower the boom until it is resting in a stowed position.
- Press and hold the emergency lowering valve on the back of the jib boom section to relieve all hydraulic pressure to the cylinder. Repeat this process for the upper and lower boom sections. Refer to the 55XA Operator's Manual for emergency lowering valve locations and operating procedures.
- Turn key switch to the OFF position and remove the key.
- Locate the piston rod end of the cylinder to be removed (Figure 4-1). Unbolt and remove the retainer plate from each side of the pivot pin.
- Verify that the cylinder is supported by lifting straps and an overhead hoist.
- Remove the pivot pin using a hammer and a brass or hardwood drift.
- Use an overhead crane or lifting gear to raise the boom section. Adequate clearance is necessary to reach the cylinder valve block and hydraulic hose ports.
- Unplug the appropriate emergency lowering valve solenoid.
- Tag and number all hydraulic hoses that attach to the cylinder valve block. Use a marker to label the valve block ports with the appropriate hose numbers.
- Place absorbent cloths below the cylinder ports and detach hydraulic hoses from the cylinder. Elevate hoses to prevent leakage. Plug or cap exposed hose fittings and cylinder ports.
- At the base of the cylinder, unbolt and remove retainer plate from each side of the pivot pin.
- Remove the pivot pin using a hammer and a brass or hardwood drift.
- Lift and remove the cylinder using an overhead hoist and lifting straps.
- Replace or reinstall the cylinder by following the above instructions in the reverse order of removal.
- Actuate the hydraulic system and check for leakage. Tighten hydraulic fittings as needed.
- Bleed trapped air from the hydraulic system by raising and lowering the boom with the reservoir fill port cap on but not tightened. Allow several minutes for trapped air to escape. Repeat as needed.

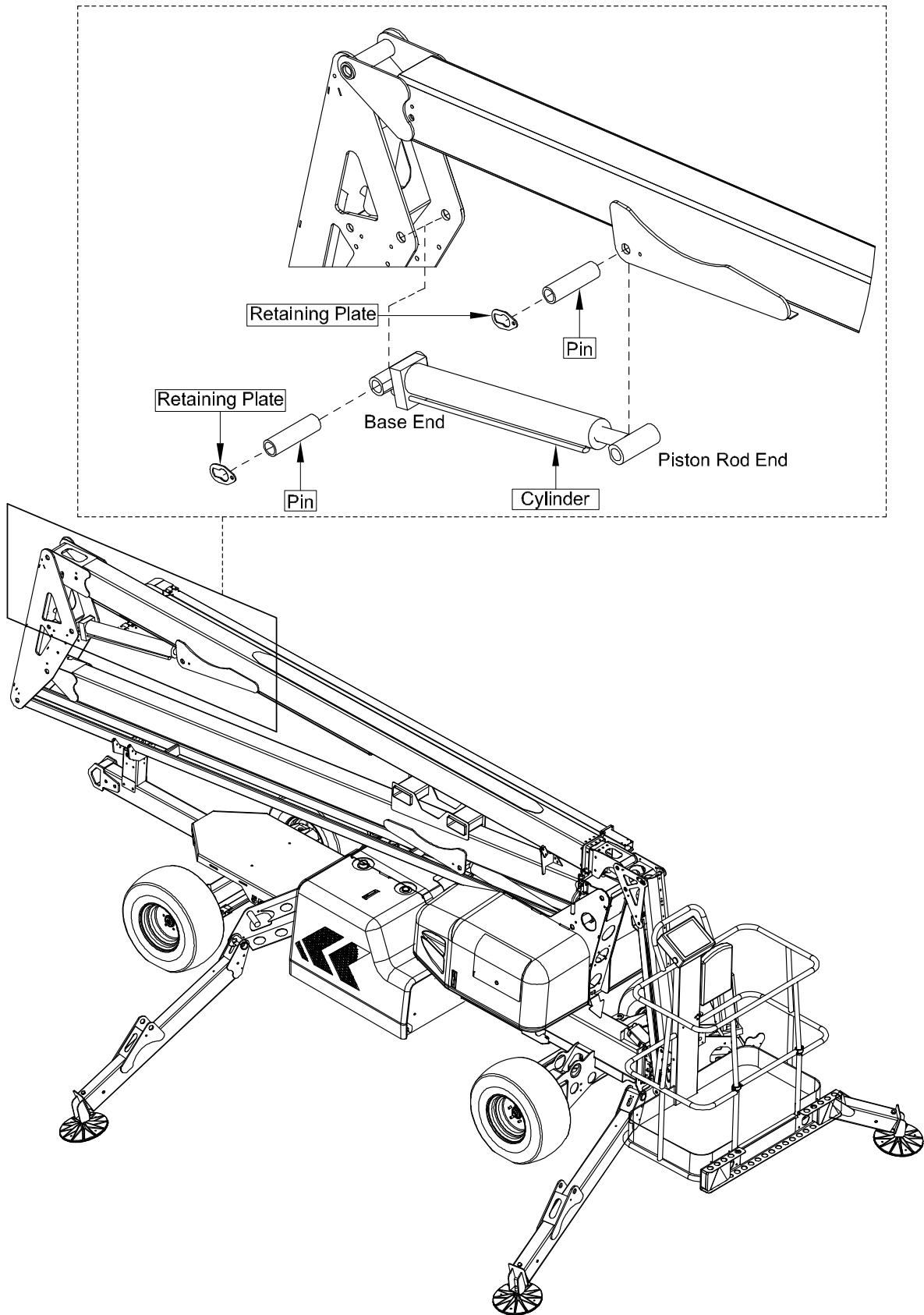

Figure 4-1 Lift Cylinder Replacement

OUTRIGGER CYLINDER REPLACEMENT

Use the following procedure to remove and replace faulty or damaged hydraulic cylinders on the outriggers:

- ❑ Lower the outrigger until the footpad is touching the ground. Do not transfer the weight of the boom lift onto the outrigger. Leave the weight of the boom on the trailer wheels.
- ❑ Remove the bolts securing the outrigger cylinder rod guard (Figure 4-2). Remove the guard.
- ❑ At the piston rod end of the cylinder, unbolt and remove the retainer plate from each side of the pivot pin.
- ❑ Place a block of wood shoring between the outrigger beam and cylinder.
- ❑ Remove the pivot pin using a hammer and a brass or hardwood drift.
- ❑ Fully retract the cylinder.
- ❑ Turn key to the off position and remove the key.
- ❑ Tag and number all hydraulic hoses that attach to the cylinder valve block. Use a marker to label the valve block ports with the appropriate hose numbers.
- ❑ Unplug the cylinder valve solenoid.
- ❑ Place absorbent cloths below the cylinder ports and detach hydraulic hoses from the cylinder. Elevate hoses to prevent leakage. Plug or cap exposed hose fittings and cylinder ports.
- ❑ At the base of the cylinder, unbolt and remove retainer plate from each side of the pivot pin.
- ❑ Remove the pivot pin using a hammer and a brass or hardwood drift.
- ❑ Lift and remove the cylinder using an overhead hoist and lifting straps.
- ❑ Replace or reinstall the cylinder by following the above instructions in the reverse order of removal.
- ❑ Actuate the hydraulic system and check for leakage. Tighten hydraulic fittings as needed.
- ❑ Bleed trapped air from the hydraulic system by raising and lowering the boom with the reservoir fill port cap on but not tightened. Allow several minutes for trapped air to escape. Repeat as needed.

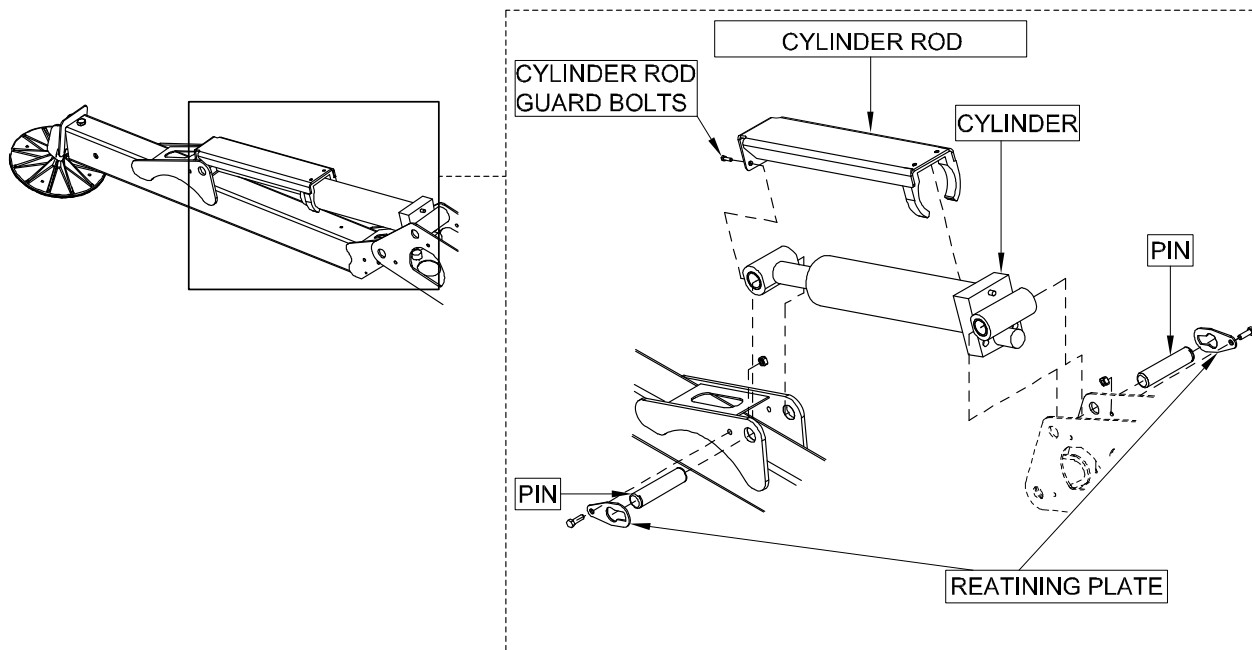

Figure 4-2 Outrigger Cylinder Replacement

5 REPLACEMENT DECALS

 **WARNING**

Decals contain information that is required for the safe and proper use of the aerial work platform.

Decals should be considered necessary components of the machine and should be checked before each use to verify that they are correctly attached and legible.

Promptly replace all decals that are no longer legible

Refer to Figure 5-1 to find the correct location of all decals.

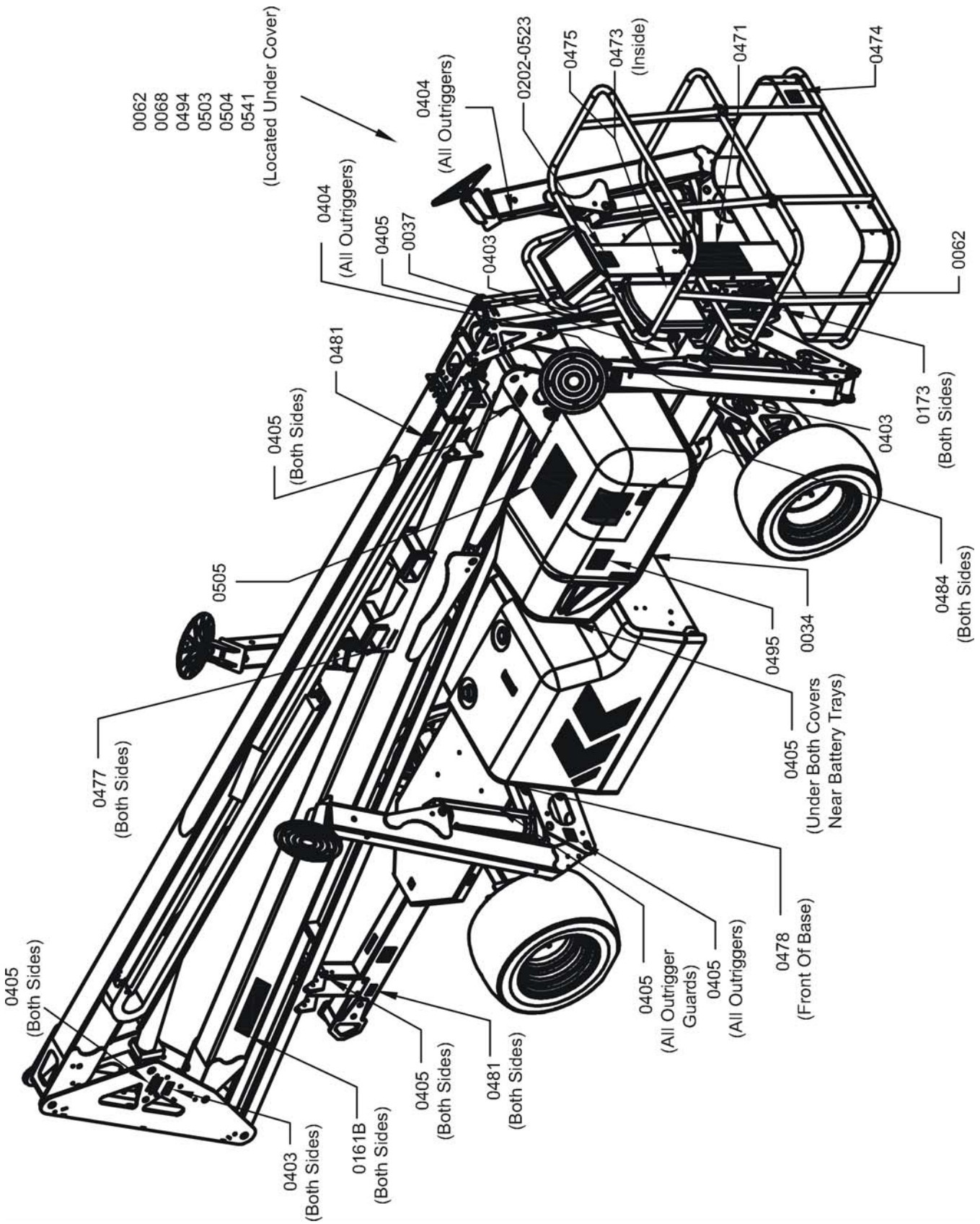

Figure 5-1 Decal Locations

Table 5-1 Replacement Decal Descriptions

Decal No.	Decal Description	Qty
0202-0523	Made in USA	1
B06-00-0034	DANGER: Electric Shock	1
B06-00-0037	Lubricate Semi-Annually	1
B06-00-0062	NOTICE: AC Power	2
B06-00-0068	NOTICE: Hydraulic System Oil	1
B06-00-0161B	Haulotte Group BilJax Logo, 6" Black Transfer	2
B06-00-0403	NOTICE: Emergency Lowering	4
B06-00-0404	WARNING: Outrigger Crush Toe	8
B06-00-0405	WARNING: Pinch Point	17
B06-00-0471	DANGER: Before Use/Main Instruction/Hazards (Platform)	1
B06-00-0473	NOTICE: Operator's Manual Missing	1
B06-00-0474	NOTICE: Max. Load	1
B06-00-0475	WARNING: Read/Understand Operator's Manual	1
B06-00-0477	WARNING: Forklift Pockets	2
B06-00-0478	NOTICE: Platform Charger/Power Plug Here	1
B06-00-0481	CAUTION: Transport Safety Latch	3
B06-00-0484	DANGER: Battery/Charger Safety	1
B06-00-0494	NOTICE: Contains Hazardous Material	1
B06-00-0495	CAUTION: Compartment Access Restricted	2
B06-00-0503	NOTICE: Handle Applications	1
B06-00-0504	NOTICE: Emergency Hand Pump	1
B06-00-0505	DANGER: Before Use/Main Instruction/Hazards (ground)	1
B06-00-0541	CAUTION: Manual Boom Functions	1

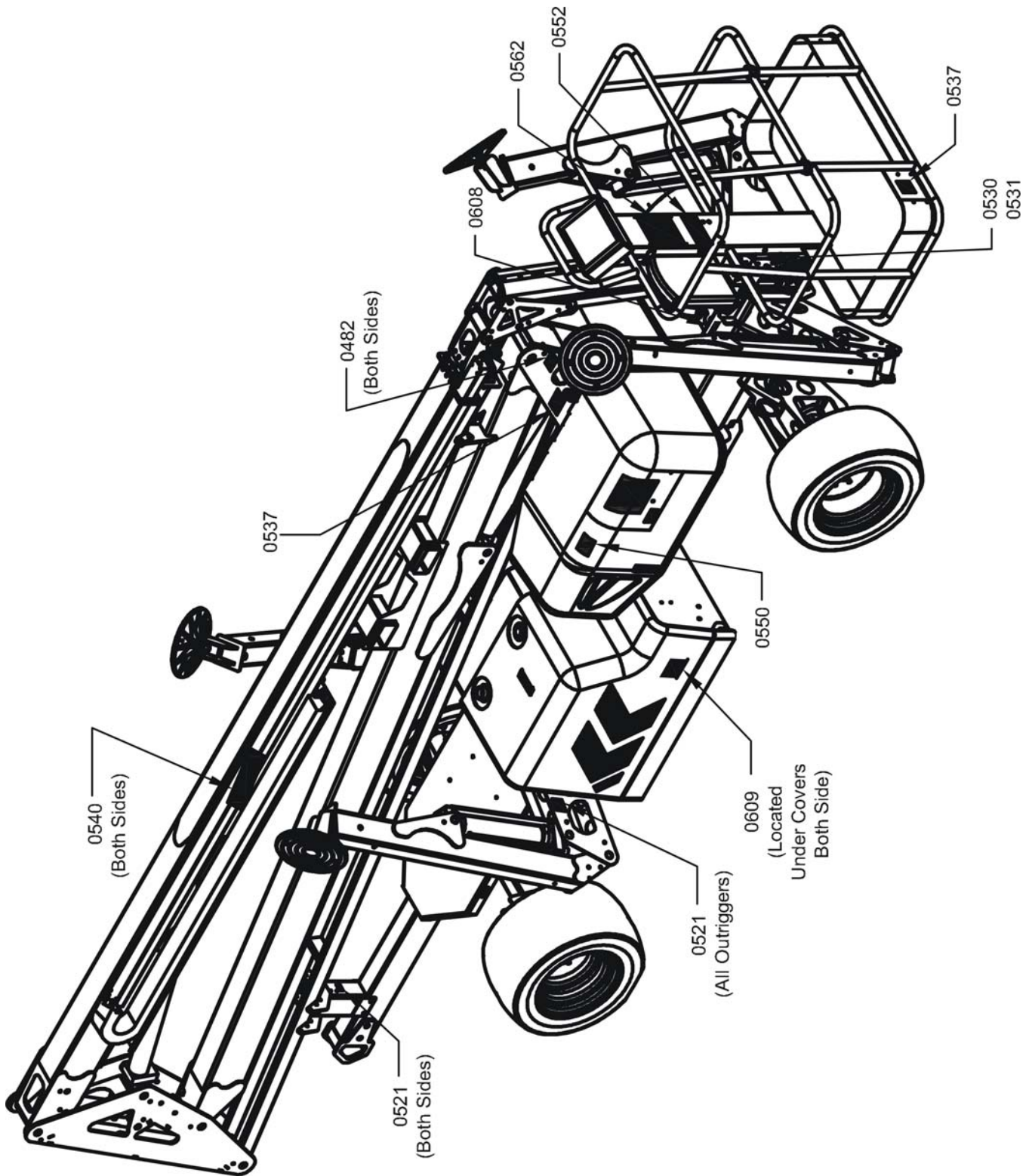

Figure 5-1 Decal Locations

Table 5-1 Replacement Decal Descriptions (Continued)

Decal No.	Decal Description	Qty
B06-00-0482	DANGER: Electrocutation Hazard	2
B06-00-0521	DANGER: Tip Over Hazard	7
B06-00-0530	Air Line Pressure	2
B06-00-0531	Water Line Pressure	2
B06-00-0537	NOTICE: Range of Motion	2
B06-00-0552	NOTICE: Lanyard Attach	1
B06-00-0561	WARNING: Ground Control	2
B06-00-0562	WARNING: Platform Control	1
B06-00-0565	55XA, 6" Blank Transfer	2
B06-00-0608	Drive Direction Arrows	1
B06-00-0609	NOTICE: Brake Release	2

Identification Plates

Decal No.	Decal Description	Qty
B06-00-0499	ANSI ID Plate	1
B06-00-0524	Annual Inspection Plate	1
B06-00-0526	Key Tag	1

CE/CAN/AUS Machines

Decal No.	Decal Description	Qty
B06-00-0167	Black/Yellow Hazard - 2" Wide	4
B06-00-0568	WARNING: Tip Over Hazard	4

6 REPLACEMENT PARTS

Use only parts manufactured and/or authorized by Haulotte Group | BilJax when replacing damaged components. See page 162 for replacement part ordering information.

Only personnel properly trained and authorized to operate all equipment and familiar with all boom functions should attempt to repair or replace any part of the boom lift.

Always read, understand and obey all safety precautions included in this manual, as well as those precautions attached to the lift and dictated by federal, state and local regulations.

NOTE: Unless otherwise specified, high-strength Imperial Grade 5/Metric Class 8.8 fasteners are used in the assembly of this equipment.

<u>Assembly Description</u>	<u>Page</u>
MACHINE ASSEMBLY	52
MACHINE ASSEMBLY PARTS LIST	53
BASE ASSEMBLY	54
BASE ASSEMBLY PARTS LIST	55
TURNTABLE ASSEMBLY	56
TURNTABLE ASSEMBLY PARTS LIST	57
COVER ASSEMBLY	58
COVER ASSEMBLY PARTS LIST	59
SLEW RING ASSEMBLY	60
SLEW RING ASSEMBLY PARTS LIST	61
OUTRIGGER & FOOTPAD ASSEMBLY	62
OUTRIGGER & FOOTPAD ASSEMBLY PARTS LIST	63
REAR SWITCH ASSEMBLY	64
REAR SWITCH ASSEMBLY PARTS LIST	65
FRONT SWITCH ASSEMBLY	66
FRONT SWITCH ASSEMBLY PARTS LIST	67
FRONT AXLE ASSEMBLY	68
FRONT AXLE ASSEMBLY PARTS LIST	69
REAR AXLE ASSEMBLY	70
REAR AXLE ASSEMBLY PARTS LIST	71
ENGINE COMPARTMENT ASSEMBLY	72
ENGINE COMPARTMENT ASSEMBLY PARTS LIST	73
GAS ENGINE ASSEMBLY	74
GAS ENGINE ASSEMBLY PARTS LIST	75
DIESEL ENGINE ASSEMBLY (OPTIONAL)	78
DIESEL ENGINE ASSEMBLY PARTS LIST	79
HYDRAULIC COMPARTMENT ASSEMBLY	82
HYDRAULIC COMPARTMENT ASSEMBLY PARTS LIST	83
CONTROL COMPARTMENT ASSEMBLY	84
CONTROL COMPARTMENT ASSEMBLY PARTS LIST	85
TRIANGLE WELDMENT ASSEMBLY	86
TRIANGLE WELDMENT ASSEMBLY PARTS LIST	87
UPPER BOOM ASSEMBLY	88
UPPER BOOM ASSEMBLY PARTS LIST	89

Assembly Description	Page
JIB BOOM ASSEMBLY	90
JIB BOOM ASSEMBLY PARTS LIST	91
PLATFORM ASSEMBLY	94
PLATFORM ASSEMBLY PARTS LIST	95
JOYSTICK ASSEMBLY	96
JOYSTICK PARTS LIST	97
DRIVE MANIFOLD ASSEMBLY	98
DRIVE MANIFOLD ASSEMBLY PARTS LIST	99
PUMP ASSEMBLY (A-02254HS)	100
PUMP ASSEMBLY (A-02254HS) PARTS LIST	101
HYDRAULIC SCHEMATIC	104
HYDRAULIC SCHEMATIC PARTS LIST	105
BOOM AND ROTATION HYDRAULIC LINES.....	110
BOOM AND ROTATION HYDRAULIC LINES PARTS LIST	111
FITTINGS KIT (A-02269F)	112
FITTINGS KIT (A-02269F) PARTS LIST	113
KIT- HOSE – 55XA DRIVE (A-02075)	114
KIT- HOSE – 55XA DRIVE (A-02075) PARTS LIST	115
KIT- FITTING – 55X DRIVE (A-02075F).....	116
KIT- FITTING – 55X DRIVE (A-02075F) PARTS LIST	117
OUTRIGGER HYDRAULIC LINES (A-02077)	118
OUTRIGGER HYDRAULIC LINES (A-02077)	119
HARNESS-MANIFOLD-55XA (A-02732).....	120
WIRE ASSEMBLY-R2 RELAY (A-02734).....	121
KIT-BATTERY CABLE 55XA (A-02273)	121
WIRE ASSEMBLY-C20 VALVE (A-02048).....	121
HARNESS-ANALOG-DUAL MOTOR CONTROLLER (A-00948)	122
KIT-TUBE 55XA DRIVE (A-02076).....	123
PUMP AND CYLINDER WIRE HARNESS (A-02716).....	124
OUTRIGGER COIL WIRE HARNESS (A-02735)	125
PLATFORM WIRE HARNESS (A-02714).....	126
HARNESS-UPPER CONTROL BOX (B01-01-0154).....	126
POWER HARNESS (A-02718)	126
110VAC TOWER-PLATFORM HARNESS (A-02722)	127
SECONDARY CYLINDER WIRE (A-02724).....	127
JIB WIRE (A-02725).....	127
WIRING ASSEMBLY-FAN-COOLER-55XA (A-02041)	127
BATTERY CABLE LAYOUT	128
BATTERY CABLE LAYOUT (KIT A-02272).....	129
SECONDARY PUMP AND MOTOR CONTROL (KIT A-00943)	129

MACHINE ASSEMBLY

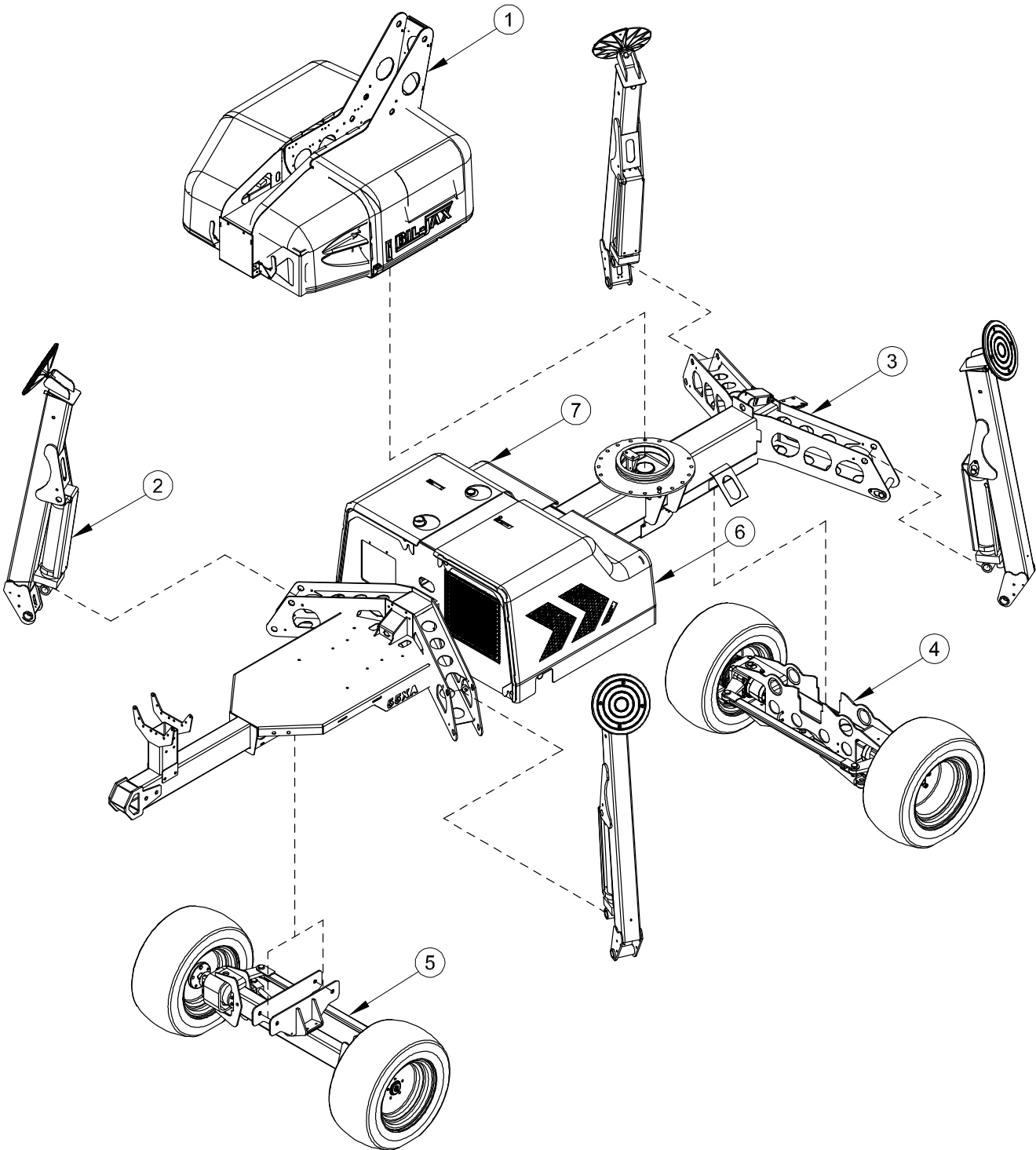

MACHINE ASSEMBLY PARTS LIST

Item No.	Description	Pages
1	TURNTABLE ASSEMBLY	54
2	OUTRIGGER & FOOTPADS ASSEMBLY	60
3	BASE ASSEMBLY	52
4	REAR AXLE ASSEMBLY	68
5	FRONT AXLE ASSEMBLY	66
6	ENGINE COMPARTMENT ASSEMBLY	70
7	HYDRAULIC COMPARTMENT ASSEMBLY	80

BASE ASSEMBLY

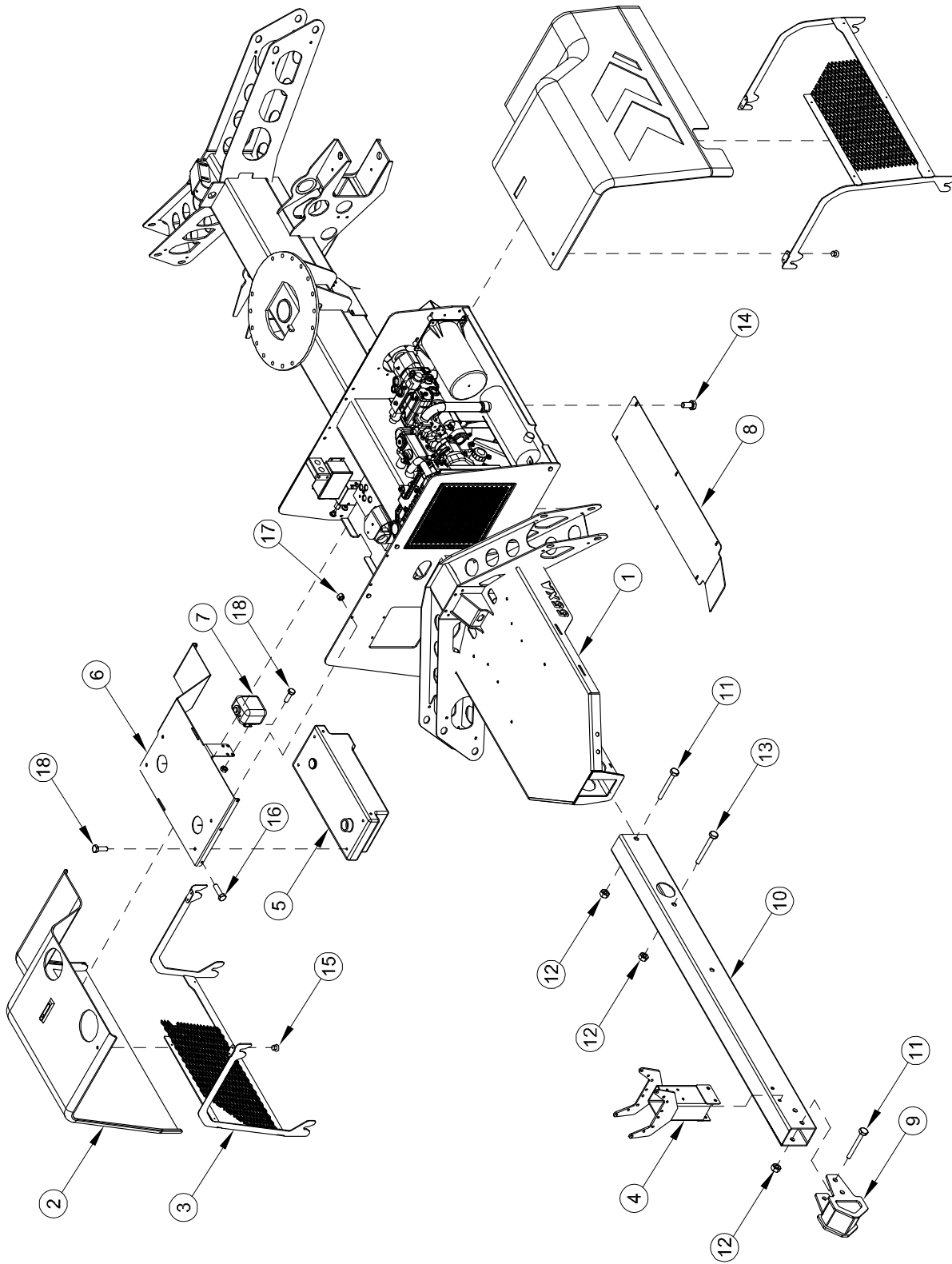

BASE ASSEMBLY PARTS LIST

Item No.	Part No.	Description	Qty.
1	A-02098	Base Assembly Weldment	1
2	A-02072R A-02072L	Cover-RH Cover-LH	1 1
3	A-02081 A-02080	Cover Brace Weldment-RH Cover Brace Weldment-LH	1 1
4	A-02030	Front Rest Weldment	1
5	B20-00-0020	Fuel Tank	1
6	A-02071	Cover Brace	1
7	B20-00-0042	Coolant Overflow Bottle	1
8	A-02018	Lower Cover	1
9	A-02026	Tie Weldment	1
10	A-02025	Tongue Tube	1
11	0096-0173	Screw-HHCS-M20x150	3
12	0096-0045	Nut-Lock-M20	5
13	0096-0174	Screw-HHCS-M20X160	2
14	0096-0010	Screw-HHCS-M8-20	6
15	0090-0684	Rivet-Pop-3/16x1/2	18
16	0096-0016	Screw-HHCS-M10x25	5
17	0096-0041	Nut-Lock-M10	9
18	0096-0014	Screw-HHCS-M10x20	8

TURNTABLE ASSEMBLY

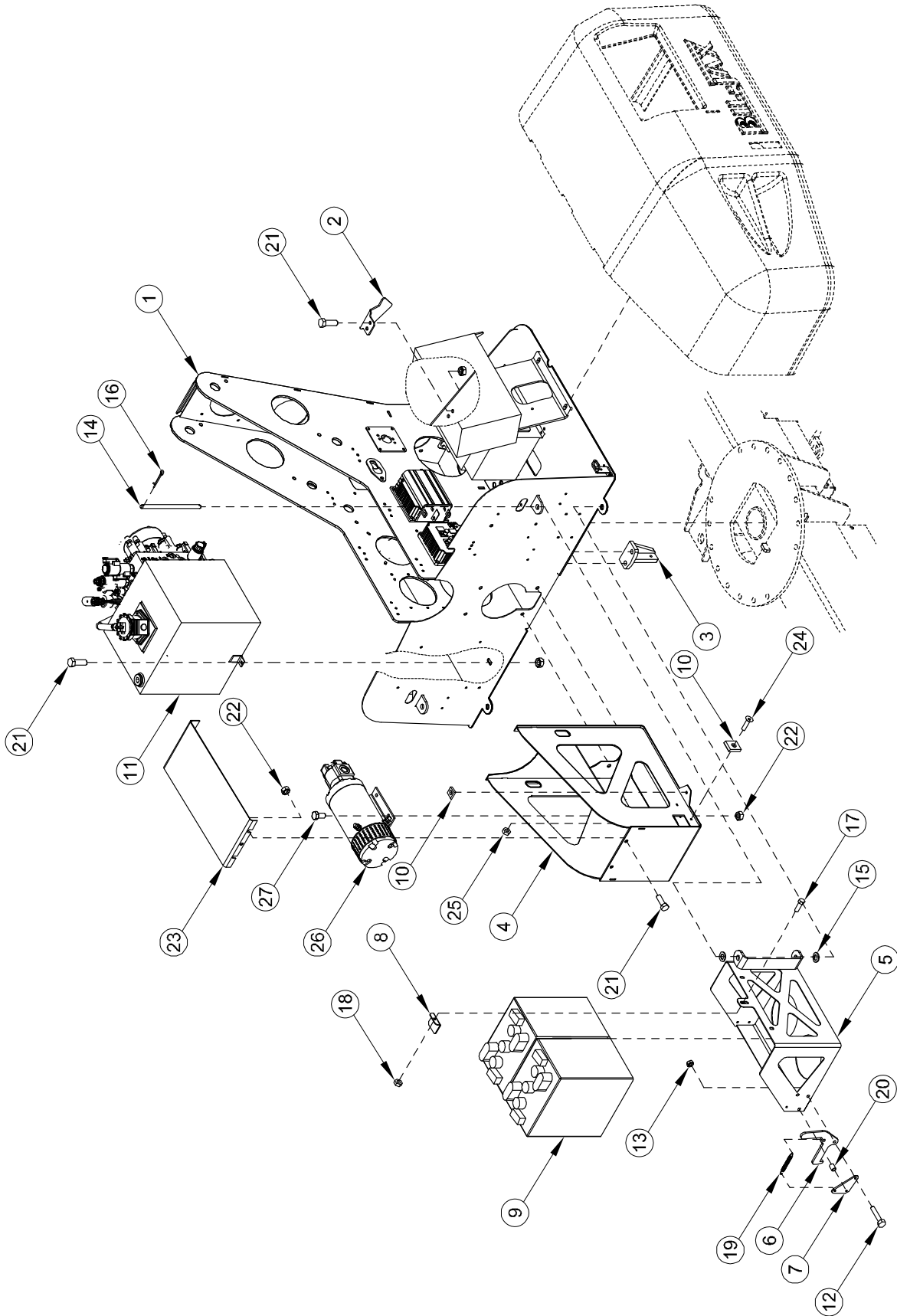

TURNTABLE ASSEMBLY PARTS LIST

Item No.	Part No.	Description	Qty.
1	A-02200	Turntable Weldment	1
2	A-01221	Rest Arrow	1
3	A-00356	Ring Stop Top Weldment	1
4	A-02225	Nose Weldment	1
5	A-00215	Battery Box Weldment-LH, RH	1
6	A-00219	Battery Box Latch	2
7	A-00229	Battery Latch Plate	2
8	A-00271	Battery Hold Down	2
9	A-00242	Battery	4
10	A-00037	Ramp Short UHMW	2
11	A-02254HS	Hydraulic Pump	1
12	0096-0006	Screw-HHCS-M6x25	6
13	0096-0039	Nut-Lock-M6	6
14	A-00278	Battery Hinge Pin	2
15	0096-0050	Washer-Flat-M16	8
16	0090-0147	Pin-Cotter 1/8 x1 1/4	4
17	0096-0010	Screw-HHCS-M8x20	2
18	0096-0040	Nut-Lock-M8	2
19	A-00244	Spring Tension Battery Latch	2
20	A-00234	Spacer-3/8 x .06 x 1/2	4
21	0096-0014	Cap Screw-M10x20	7
22	0096-0041	Lock Nut -M10	15
23	A-02230	Motor Cover	1
24	0096-0002	FHCS-M6 x20	4
25	0096-0039	Lock Nut-M6	4
26	A-02235	Hydraulic Power Unit 3.0	1
27	0096-0016	Screw-HHCS-M10x25	8

COVER ASSEMBLY

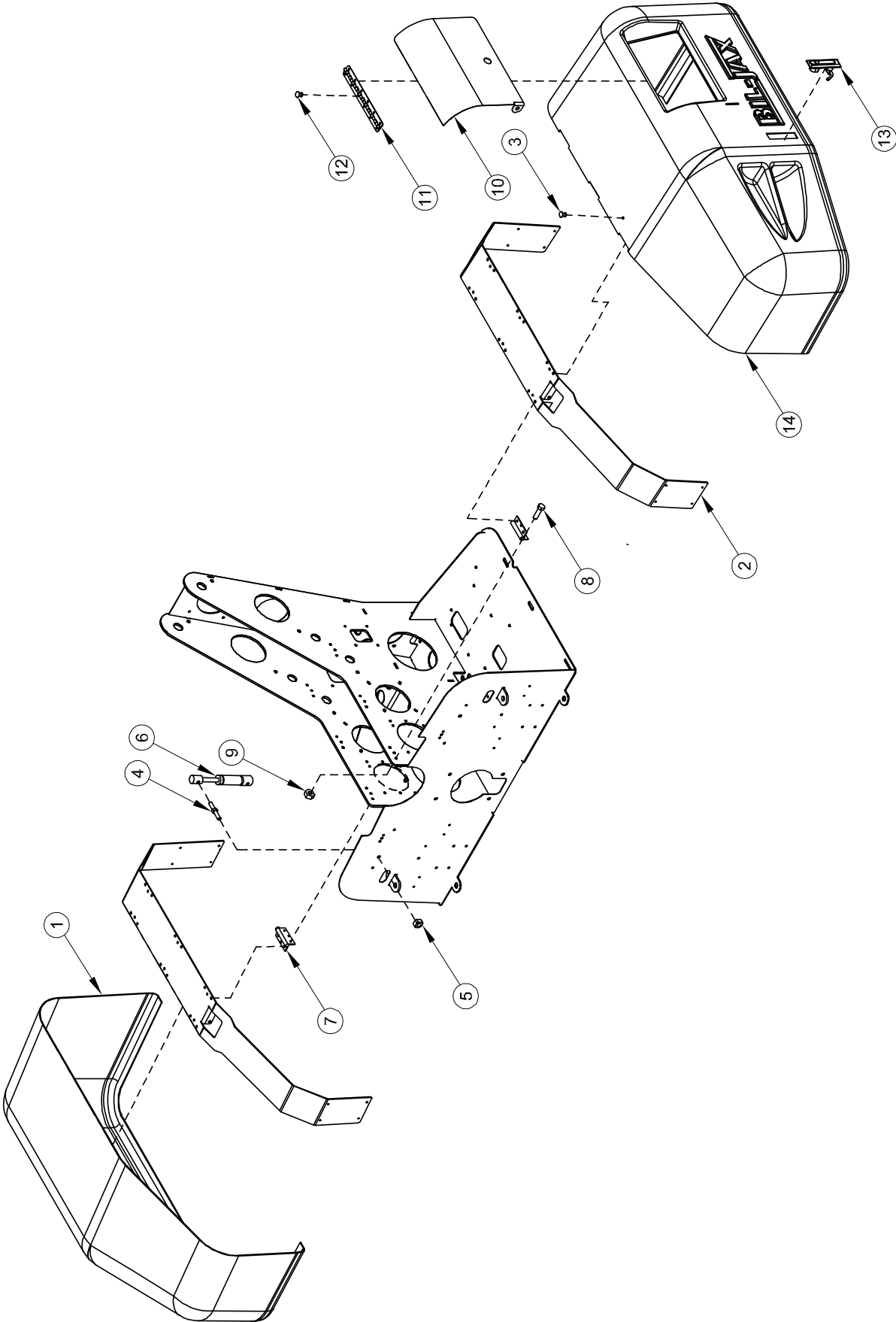

COVER ASSEMBLY PARTS LIST

Item No.	Part No.	Description	Qty.
1	A-02239	Cover Power compartment -Right	1
2	A-02228	Cover Brace	2
3	0090-1080	Rivet-Pop-3/16x1/2	16
4	0090-0920	Stud-Ball-10mm	4
5	0090-0185	Nut-Lock-5/16	4
6	A-02251	Spring-Gas-Cover	2
7	A-00252	Hinge-Cover	6
8	0096-0002	Screw-HHCS-M6x20	48
9	0096-0039	Nut-Lock-M6	48
10	A-00284	Control Cover Weldment	1
11	B42-01-1002	Control Cover Hinge	1
12	0090-0684	Rivet-Pop-3/16x1/2	6
13	A-00292	Cover Latch Kit	2
14	A-02240	Cover Power compartment -Left	1

SLEW RING ASSEMBLY

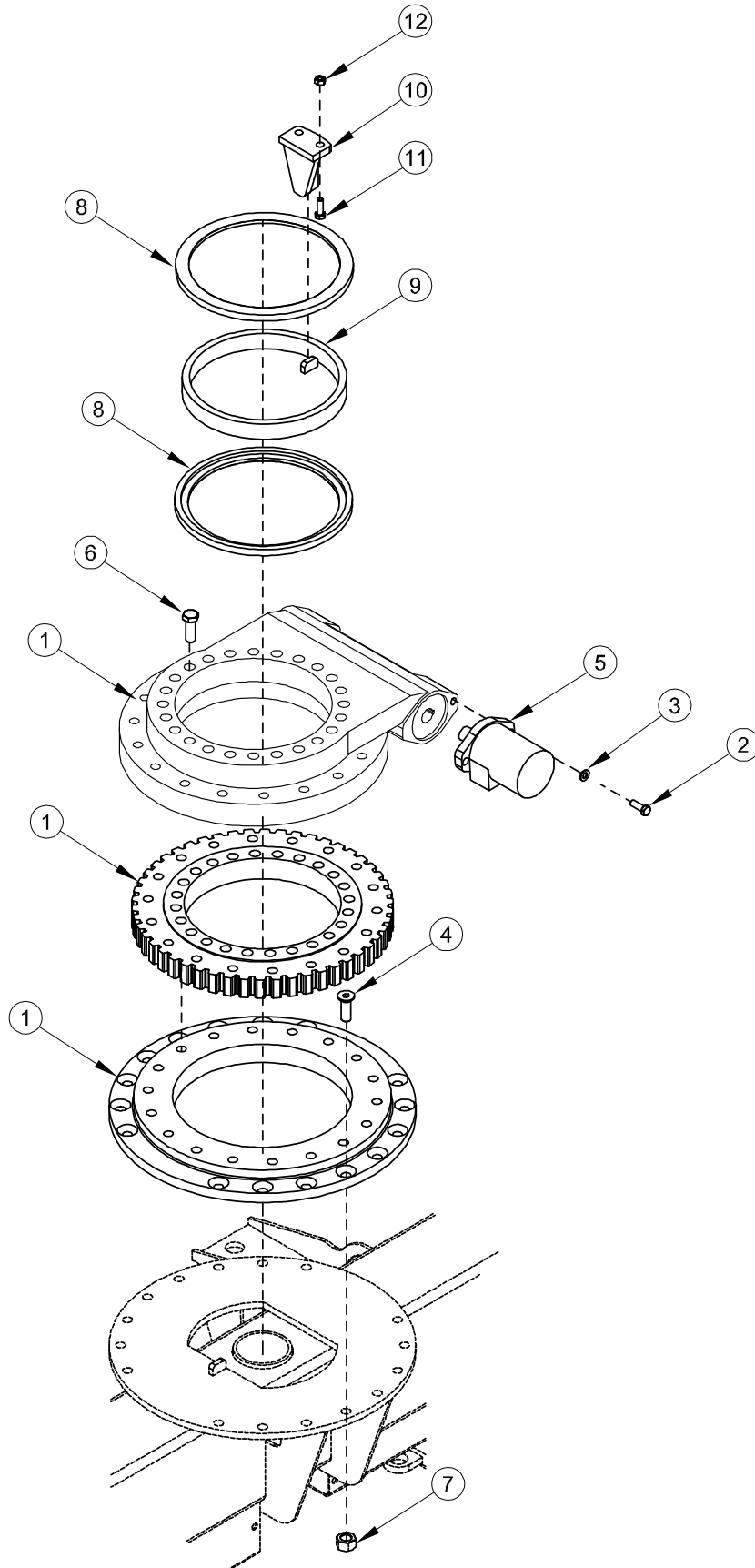

SLEW RING ASSEMBLY PARTS LIST

Item No.	Part No.	Description	Qty.
1	A-02189	Slew Assembly and Adapter	1
2	0090-0461	Cap Screw-1/2-13x2	2
3	0090-0212	Lock Washer-1/2	2
4	0096-0033	FHCS-M16x35	16
5	B02-06-0018	Slew Ring Drive	1
6	0090-0643	Cap Screw-5/8-11x2-3/4-Grade 8	19
7	0090-0044	Hex Nut, Self-Locking-M16	16
8	A-00351	Nylon Ring	2
9	A-00352	Ring	1
10	A-00356	Ring Stop Weldment	1
11	0096-0021	Cap Screw-M12x45	2
12	0096-0042	Hex Nut, Self Locking-M12	2

OUTRIGGER & FOOTPAD ASSEMBLY

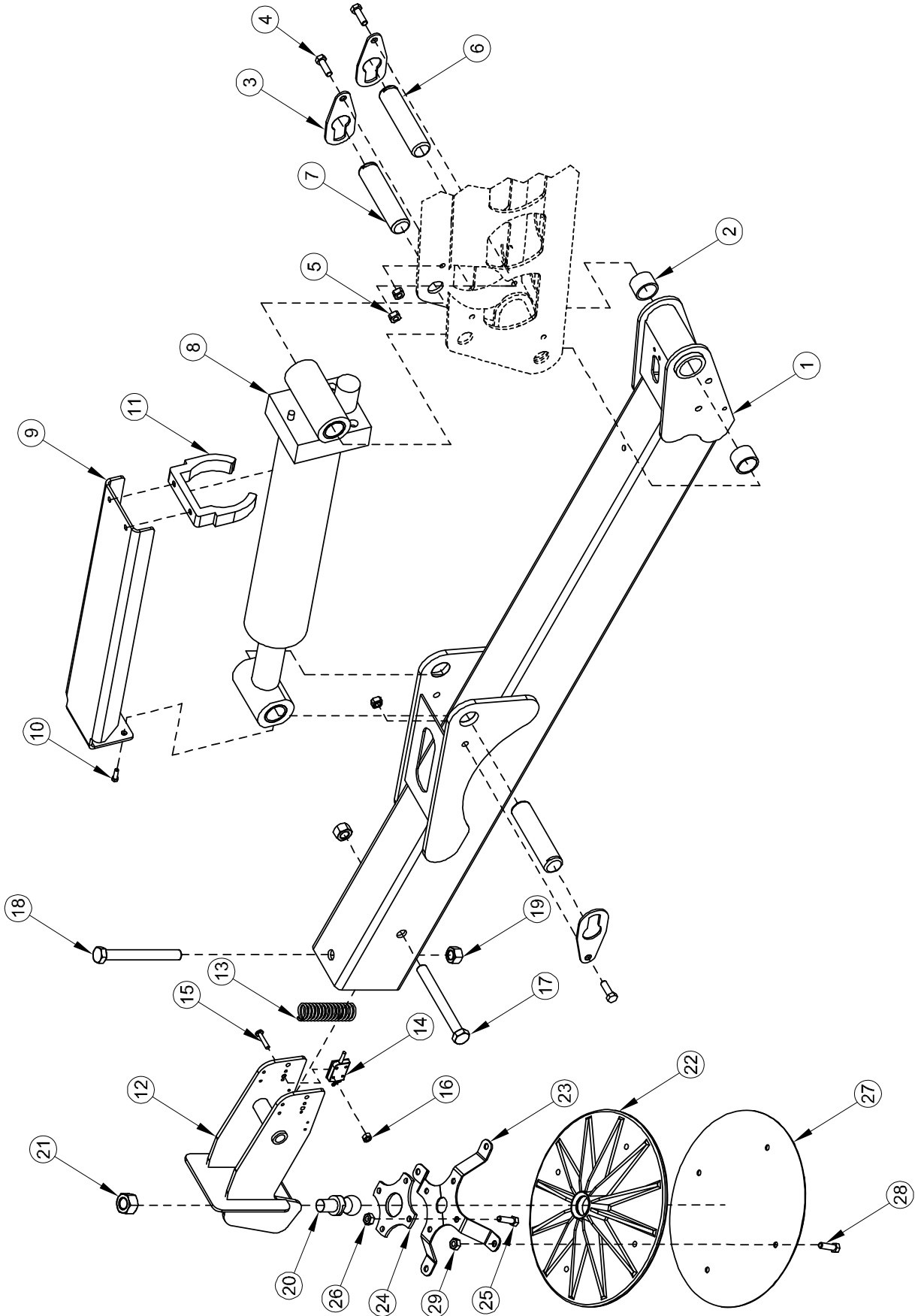

OUTRIGGER & FOOTPAD ASSEMBLY PARTS LIST

Item No.	Part No.	Description	Qty.
1	A-02088	Outrigger Weldment	4
2	A-00032	Bearing 1.25id X 1.25lg X .125thk	8
3	A-00019	Pin Retainer 1.25 In	12
4	0096-0016	Screw-HHCS-M10x25	12
5	0096-0041	Nut-Lock-M10	12
6	A-00063	Pin 1.25 X 5.25	4
7	A-00062	Pin 1.25 X 6.5	8
8	A-02138	Outrigger Cylinders 55	4
9	A-02141	Outrigger Cylinder Guard 55	4
10	0096-0009	Screw-HHCS-M8x10	12
11	A-02142	Guard Slide 3.5	4
12	A-02128	Pad Mount Weldment	4
13	A-00154	Spring Outrigger Sensor	4
14	A-03644	Switch Limit No W/ Tower Delphi	4
15	0090-0232	Screw-10-24x5/8	8
16	0090-0182	Nut-Lock-10-24	8
17	0096-0083	Screw-HHCS-M16x130	4
18	0096-0036	Screw-HHCS-M16x150	4
19	0096-0044	Nut-Lock-M16	8
20	A-00135	Foot Pad Ball	4
21	0096-0045	Nut-Lock-M20	4
22	A-00136	Foot Pad	4
23	A-00127	Footpad Lock	8
24	A-00139	Footpad Cap	4
25	0096-0010	Screw-HHCS-M8x20	16
26	0096-0040	Nut-Lock-M8	16
27	A-00137	Foot Pad Bottom	4
28	0096-0121	Screw-FHSCS-M8x30	16
29	0096-0040	Nut-Lock-M8	16

*Quantities listed reflect the number of parts needed for each outrigger.

REAR SWITCH ASSEMBLY

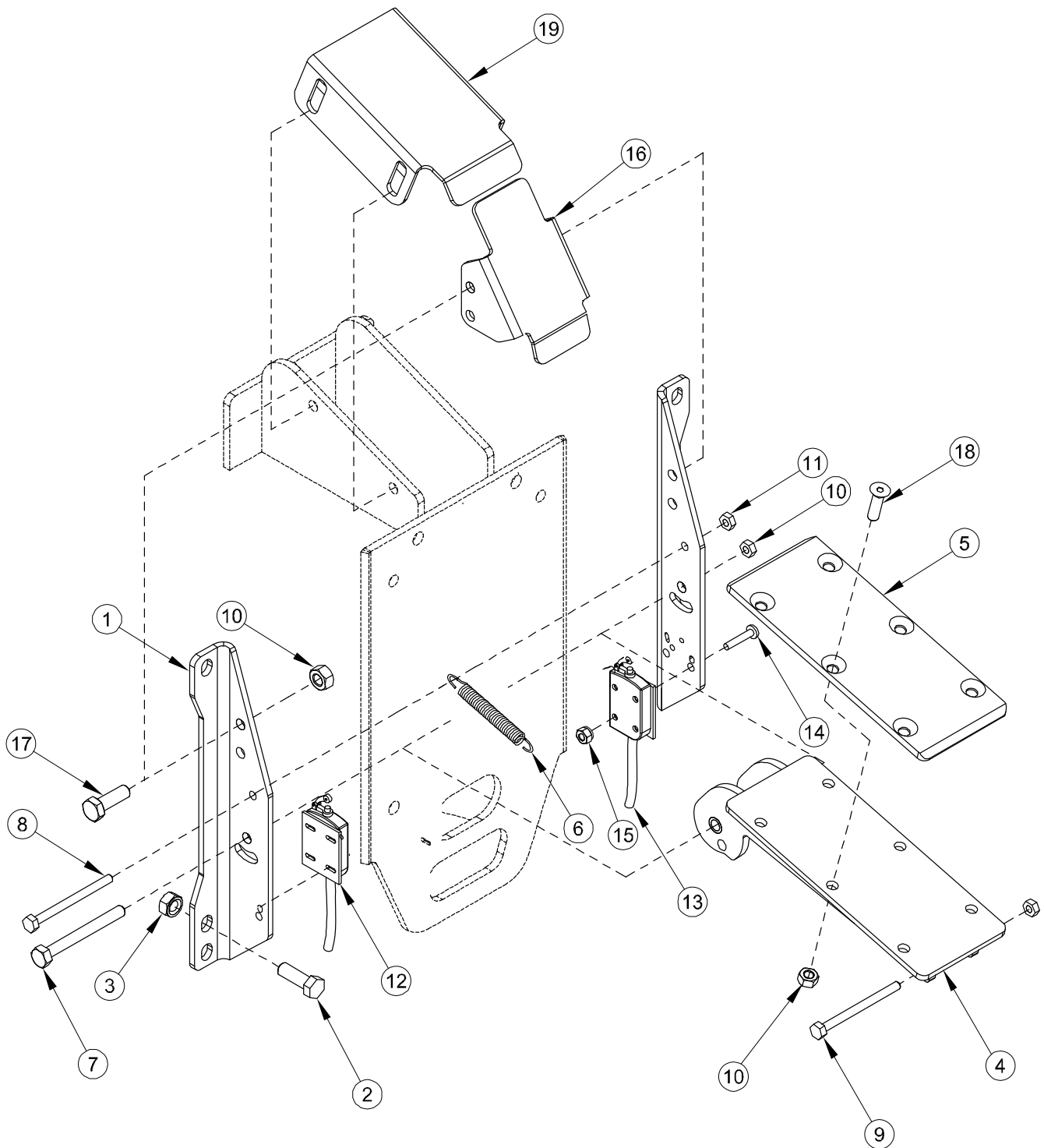

REAR SWITCH ASSEMBLY PARTS LIST

Item No.	Part No.	Description	Qty.
1	A-01190L	Switch Plate- Left	1
	A-01190R	Switch Plate- Right	1
2	0096-0016	Screw-HHCS-M10x25	8
3	0096-0041	Nut-Lock-M10	8
4	A-01191	Switch Cam Weldment	1
5	A-01195	Slide-Switch Cam	1
6	A-01196	Spring Tension Jib Switch	2
7	0096-0081	Screw-HHCS-M8x80	2
8	0096-0078	Screw-HHCS-M6x80	1
9	0096-0085	Screw-HHCS-M6x60	1
10	0096-0040	Nut-Lock-M8	12
11	0096-0039	Nut-Lock-M6	2
12	A-03644	Switch-Limit-NO	1
13	A-03647	Switch-Limit-NC	1
14	0090-0692	Screw-8-32 X 1 ¼"	4
15	0090-0181	Nut-Lock-8-32	4
16	A-01184	Plate-Lower-Jib Slide	1
17	0096-0011	Screw-HHCS-M8x25	4
18	0096-0012	Screw-FHCS-M8x25	6
19	A-01185	Plate-Jib Slide	1

FRONT SWITCH ASSEMBLY

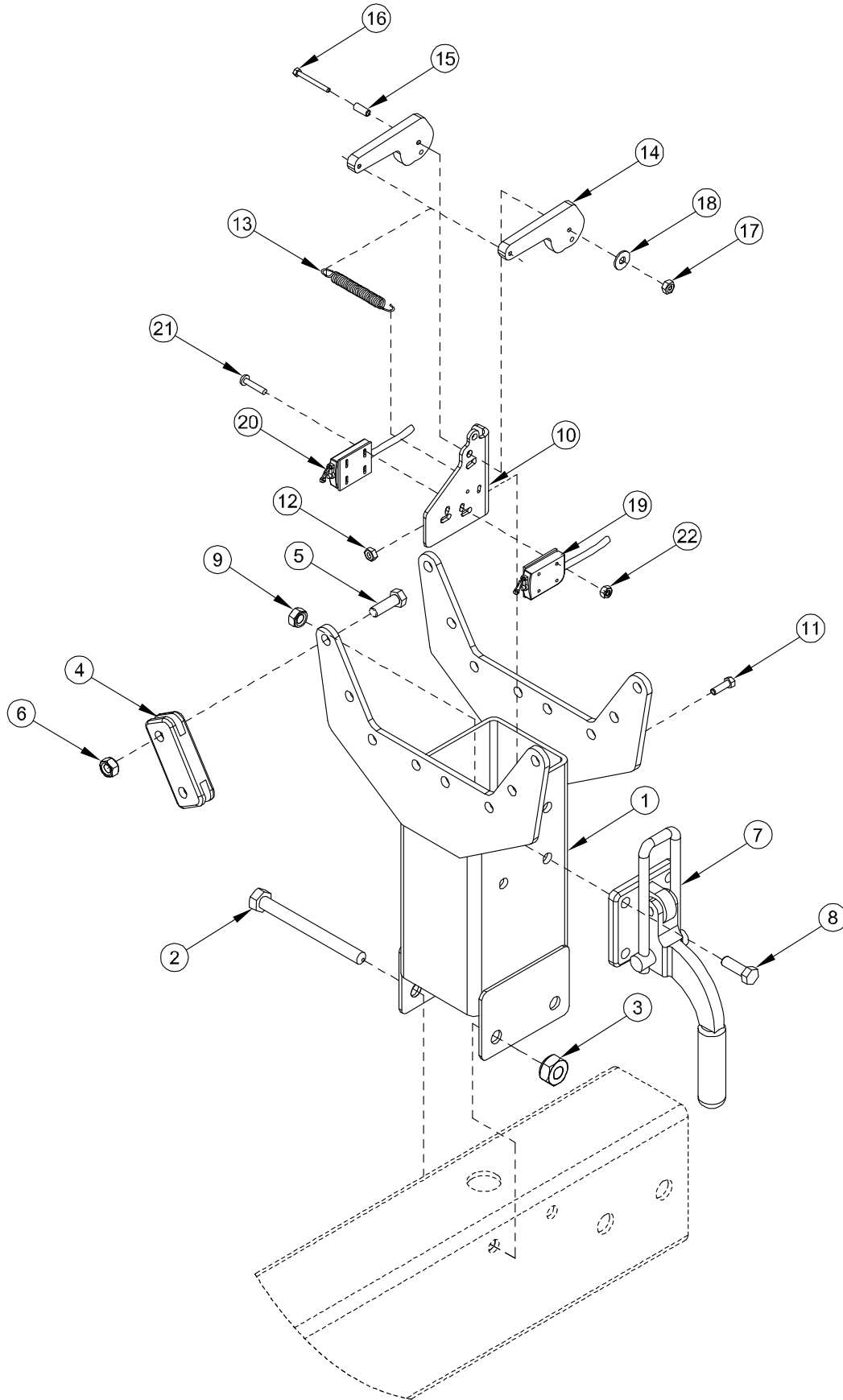

FRONT SWITCH ASSEMBLY PARTS LIST

Item No.	Part No.	Description	Qty.
1	A-02030	Front Rest Weldment	1
2	0096-0026	Screw-Cap-M12x130	2
3	0096-0042	Nut-Lock-M12	2
4	A-00157	Front Rest Pad	8
5	0096-0017	Screw-HHCS-M10x30	16
6	0096-0041	Nut-Lock-M10	16
7	A-00159	Boom Latch	1
8	0096-0016	Screw-HHCS-M10x25	4
9	0096-0041	Nut-Lock-M10	4
10	A-00169	Front Rest Switch Plate	1
11	0096-0002	Screw-HHCS-M6x20	2
12	0096-0069	Nut-Lock-M6	2
13	A-00158	Spring Ext Front Rest	1
14	A-00188	Switch Cam	2
15	A-00190	Switch Cam Spacer	3
16	0096-0106	Screw-HHCS-M4x40	3
17	0096-0073	Nut-Lock-M4	3
18	0090-0419	Washer-Flat-1/4	7
19	A-03644	Switch Limit NO	1
20	A-03647	Switch Limit NC	1
21	0090-0692	Screw-8-32x1 1/4	2
22	0090-0181	Nut-Lock-8-32	2

FRONT AXLE ASSEMBLY

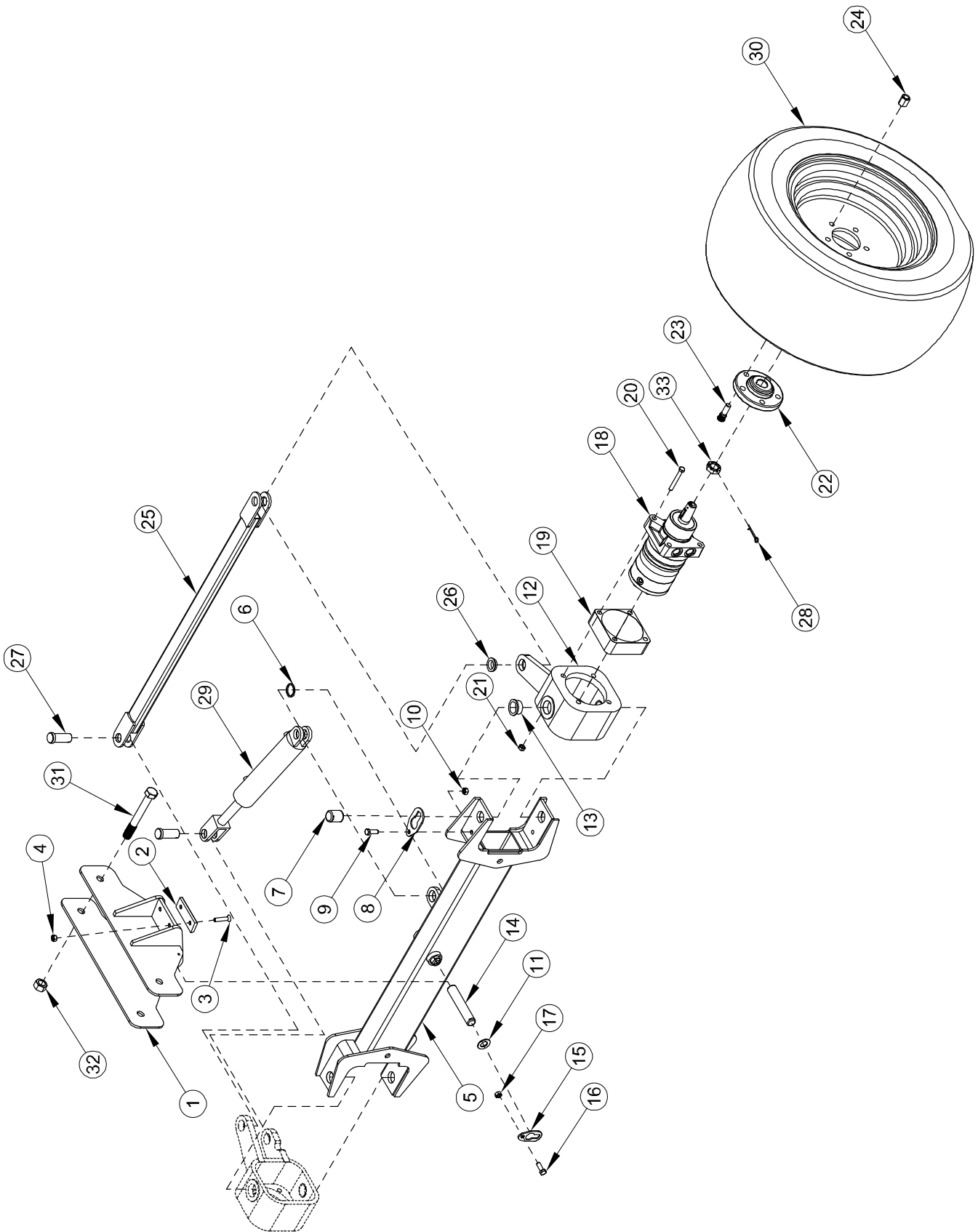

FRONT AXLE ASSEMBLY PARTS LIST

Item No.	Part No.	Description	Qty.
1	A-02034	Front Axle Mt Weldment	1
2	A-01029	Pad-Front Axle	2
3	0096-0068	Screw-FHSCS-M10x45	4
4	0096-0041	Nut-Lock-M10	4
5	A-01010	Front Axle Weldment	1
6	A-00032	Bearing 1.25id X 1.25lg X .125thk	2
7	A-01009	Pin 1 x 5.5	1
8	A-00018	Pin Retainer 1.0 IN	1
9	0096-0016	Screw-HHCS-M10x25	1
10	0096-0041	Nut-Lock-M10	1
11	0090-1132	Washer-Flat 1 In Id	2
12	A-01020	Front Yoke-Left	1
	A-01021	Front Yoke-Right	1
13	A-01097	Bushing FI-1.5 OD	4
14	A-01070	Pin 1.25 x 1.625	4
15	A-00019	Pin Retainer 1.25 IN	4
16	0096-0016	Screw-HHCS-M10x25	4
17	0096-0041	Nut-Lock-M10	4
18	A-02065	Wheel Motor Front	2
19	A-02038	Motor Spacer	2
20	0090-1157	Screw-Cap-1/2-13x4 SHCS	8
21	0090-0192	Nut-Lock 1/2-13	8
22	A-02024	Tire Adapter	2
23	B10-00-0050	Stud-Wheel-1/2-20	10
24	0090-0624	Nut-Lock 1/2-13	10
25	A-01025	Tie Rod Weldment	1
26	A-01096	Bushing FI 1.25 OD	4
27	A-01085	Pin-Front Axle	4
28	0090-0155	Pin-Cotter 3/16 X1 3/4	4
29	A-01030	Steering Cylinder	1
30	A-02058L	Tire - Bar Lug - Left	1
	A-02058R	Tire - Bar Lug - Right	1
	A-02057L	Tire - Turf Thread-Left (Optional)	1
	A-02057R	Tire - Turf Thread-Right (Optional)	1
31	0096-0173	Screw-HHCS-M20x150	2
32	0096-0045	Nut-Lock-M20	2
33	0090-1160	1"-20 Castle Nut	2

REAR AXLE ASSEMBLY

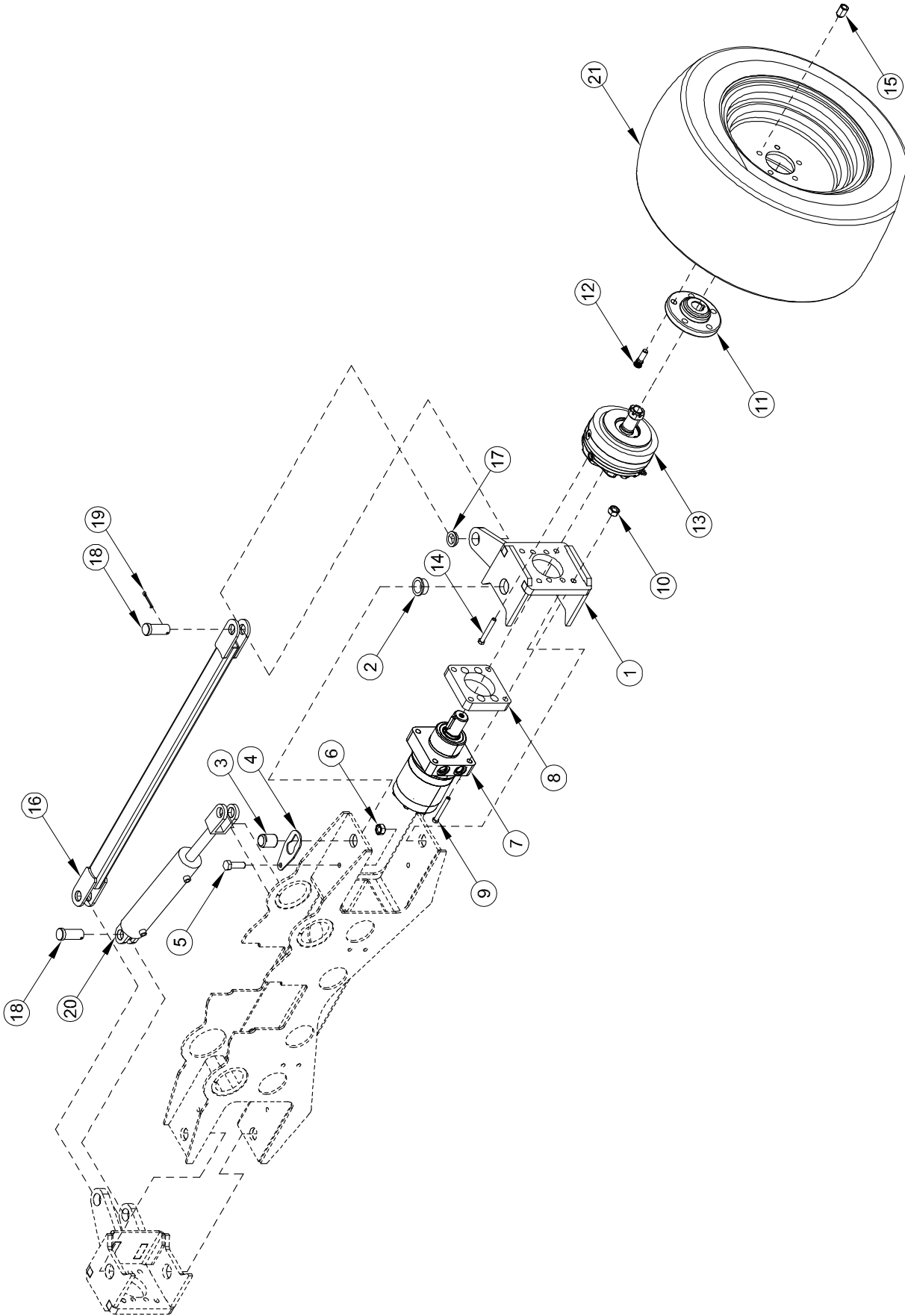

REAR AXLE ASSEMBLY PARTS LIST

Item No.	Part No.	Description	Qty.
1	A-02040	Yoke Rear Weldment -Left	1
	A-02054	Yoke Rear Weldment -Right	1
2	A-01097	Bushing FI-1.5 OD	4
3	A-01070	PIN 1.25X1.625	4
4	A-00053	Pin Retainer 1.25 In Lg	4
5	0096-0016	Screw-HHCS-M10x25	4
6	0096-0041	Nut-Lock-M10	4
7	A-02064	Wheel Motor Rear	2
8	A-02037	Brake Adapter	2
9	0090-1157	Screw-Cap-1/2-13x4 SHCS	8
10	0090-0192	Nut-Lock 1/2-13	8
11	A-02024A	Tire Adaptor	2
12	B10-00-0050	Stud-Wheel-1/2-20	10
13	A-02066	Brake	2
14	0090-1158	Screw-SHCS-1/2-13 X1 3/4"	8
15	0090-0624	Nut-Lug 1/2-13	10
16	A-01025	Tie Rod Weldment	1
17	A-01096	Bushing FI 1.25 OD	4
18	A-01085	Pin-Front Axle-4wd	4
19	0090-0155	Pin-Cotter 3/16 X1 3/4	4
20	A-01030	Steering Cylinder	1
21	A-02058L	Tire - Bar Lug - Left	1
	A-02058R	Tire - Bar Lug - Right	1
	A-02057L	Tire - Turf Thread-Left (Optional)	1
	A-02057R	Tire - Turf Thread-Right (Optional)	1

ENGINE COMPARTMENT ASSEMBLY

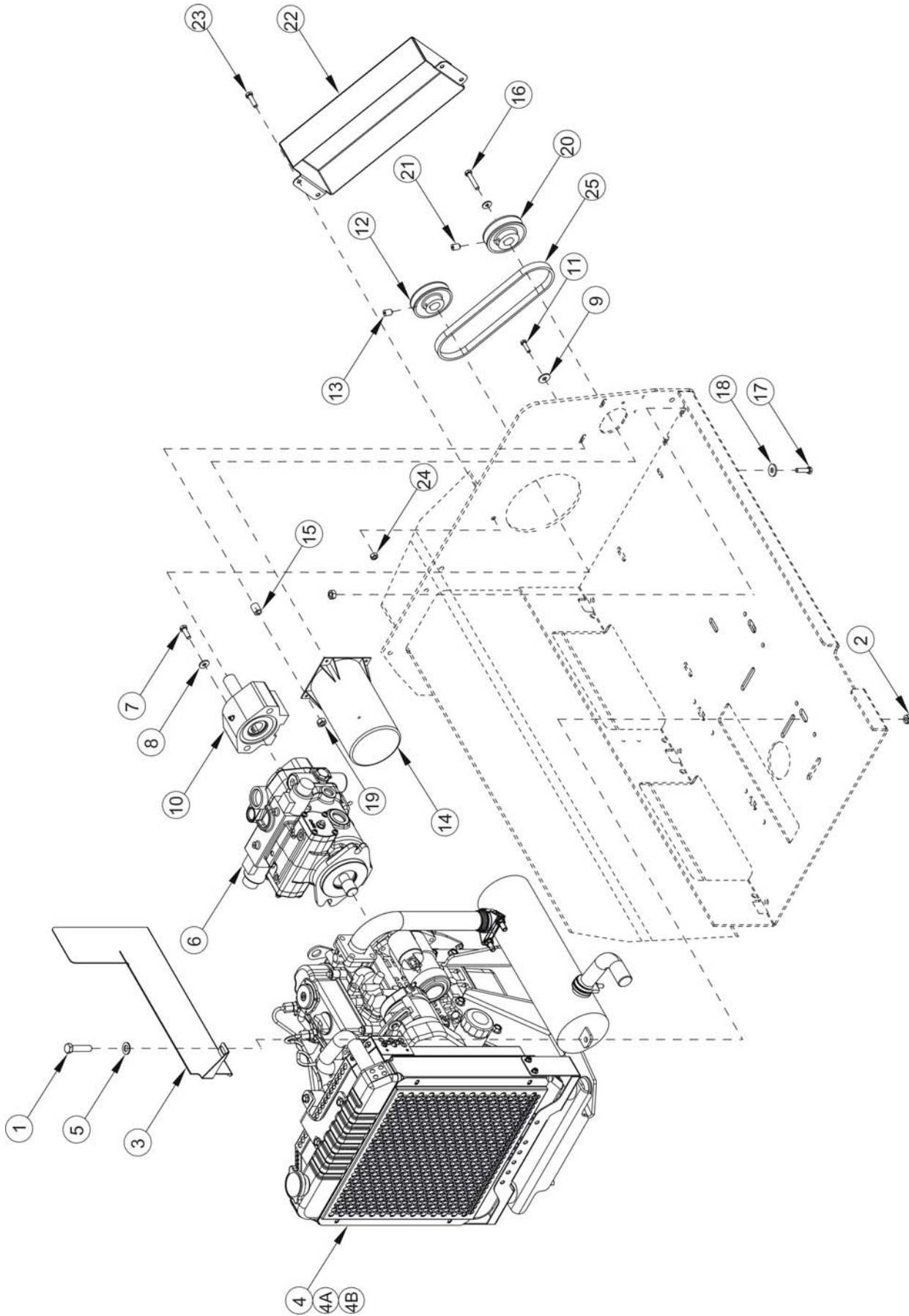

ENGINE COMPARTMENT ASSEMBLY PARTS LIST

Item No.	Part No.	Description	Qty.
1	0096-0021	Screw-HHCS-M12x45	4
2	0096-0042	Nut-Lock-M12	4
3	A-02056	Heat Shield	1
4	A-02060	Engine-Gas (Parts breakdown pages 72 – 75)	1
	A-02061	Engine-Diesel (option) (Parts breakdown pages 76 – 79)	
4A	A-02733	Harness-Engine	1
4B	A-02049	Fuel Line Kit-Gas Engine	1
	A-02050	Fuel Line Kit-Diesel Engine Option	
5	0096-0046	Washer-Flat-M12	8
6	A-02067	Pump	1
7	0096-0176	Screw-HHCS-Shoulder Bolt	2
8	0096-0177	Washer-Lock-M12	2
9	0096-0046	M12 Flat Washer	2
10	A-02068	Overhung Load Adapter	1
11	0090-0054	Screw-Cap-3/8 -16 X 3 1/2	2
12	A-02095	V-Belt Pulley-3.6 x 1 ID	1
13	0090-0363	Screw-Set-Socket 1/4 -20 X 3/4	3
14	A-00761	Generator Assembly 60 Hz Belt Drive	1
15	A-01060	Spacer Generator	2
16	0096-0118	Screw-HHCS-M8x55	2
17	0096-0056	Screw-HHCS-M8x30	2
18	0096-0093	Washer-Flat-M10	4
19	0096-0040	Nut-Lock-M8	4
20	A-02094	V-Belt Pulley-3.2 x 7/8 ID (110V System)	1
	A-02073	V-Belt Pulley-3.8 x 7/8 ID (220V System)	
21	0090-0363	Screw-Set-Socket 1/4 -20 X 3/4	3
22	A-02035	Belt Guard 4wd	1
23	0096-0010	Screw-HHCS-M8x20	3
24	0096-0040	Nut-Lock-M8	3
25	A-02096	V-Belt B25 (110V System)	1
	A-02039	V-Belt B27 (220V System)	

GAS ENGINE ASSEMBLY

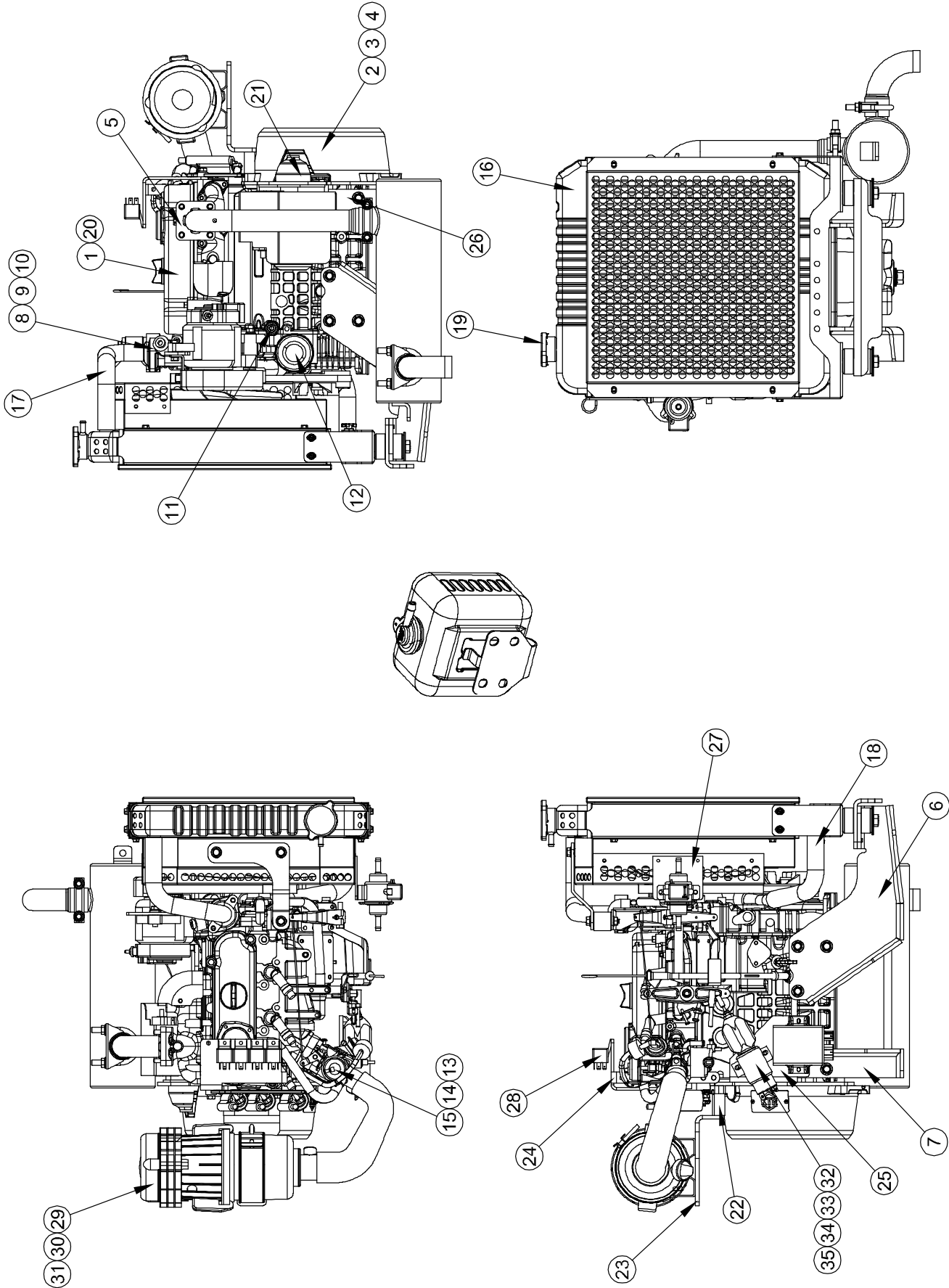

GAS ENGINE ASSEMBLY PARTS LIST

Item No.	Part No.	Description	Qty.
1	A-02060	Gas Engine-Kubota (Model # WG972E-1)	1
2	B20-00-0064	Drive Flange Disc	1
3	B20-00-0065	Drive Hub B Spline 31T	1
4	B20-00-0063	Pump Mount Housing SAE B	1
5	B20-00-0031	Exhaust Flange Gasket	1
6	B20-00-0037	Radiator Mount Kit	1
7	B20-00-0038	Rear Leg Kit	1
8	B20-00-0043	Temperature Switch	1
9	B20-00-0057	Thermostat	1
10	B20-00-0058	Thermostat Gasket	1
11	B20-00-0056	Oil Pressure Switch	1
12	B20-00-0024	Oil Filter Replacement	1
13	B20-00-0045	Carburetor(W/Auto Choke)	1
14	B20-00-0046	Carburetor Mount Gasket	2
15	B20-00-0047	Carburetor to Airhorn Gasket	1
16	B20-00-0036	Radiator	1
17	B20-00-0039	Radiator Upper Hose	1
18	B20-00-0040	Radiator Lower Hose	1
19	B20-00-0041	Radiator Cap	1
20	B20-00-0048	Valve Cover Gasket	1
21	B20-00-0055	Starter	1
22	B20-00-0092	Air Cleaner Bracket Spacer	2
23	B20-00-0091	Air Cleaner Mount Bracket	1
24	B20-00-0093	Relay Bracket	1
25	B20-00-0094	2 Speed Solenoid Mount Bracket	1
26	B20-00-0066	Starter Heat Shield	1
27	B20-00-0067	Electric Fuel Pump Mount Bracket	1
28	B01-06-0060	Relay-24V 50 Amp	4
29	B20-00-0027	Air Cleaner Assembly	1
30	B20-00-0028	Air Cleaner Housing	1
31	B20-00-0029	Air Cleaner Element	1
32	B20-00-0044	Throttle Solenoid	1
33	B20-00-0096	In Line Swivel	1
34	B20-00-0097	Rod End Swivel	1
35	B20-00-0098	Threaded Rod ¼-20 x 2"	1

GAS ENGINE ASSEMBLY (CONTINUED)

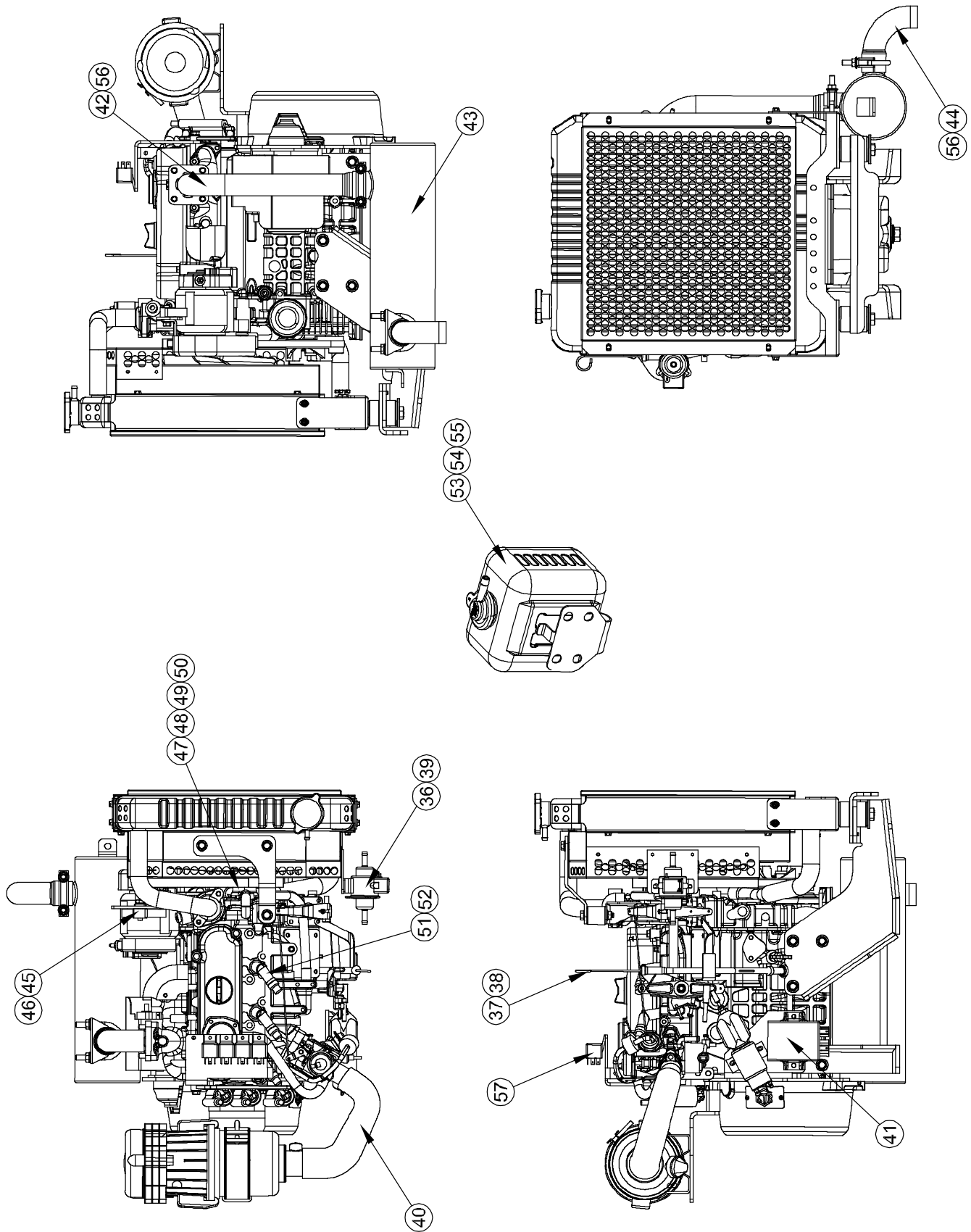

GAS ENGINE ASSEMBLY PARTS LIST (CONTINUED)

Item No.	Part No.	Description	Qty.
36	B20-00-0025	Fuel Filter Element	1
37	B20-00-0035	Oil Dipstick	1
38	B20-00-0095	Dip Stick Guide	1
39	B20-00-0051	Electric Fuel Pump	1
40	B20-00-0026	Intake Hose	1
41	B20-00-0099	Ignition Module	1
42	B20-00-0032	Exhaust Pipe W/Flange	1
43	B20-00-0030	Muffler	1
44	B20-00-0033	Tail Pipe 90 degree	1
45	B20-00-0053	Alternator	1
46	B20-00-0054	Alternator Stay	1
47	B20-00-0059	Water Pump	1
48	B20-00-0060	Water Pump Gasket	1
49	B20-00-0061	Cooling Fan	1
50	B20-00-0062	Fan Belt	1
51	B20-00-0049	Spark Plug	3
52	B20-00-0050	Spark Plug Wire & Caps	3
53	B20-00-0042	Coolant Overflow Bottle	1
54	B20-00-0100	Hose(Radiator-Overflow Bottle)(13")	1
55	B20-00-0101	Hose(Overflow-Base)(30")	1
56	B20-00-0102	Clamp-Exhaust 3/8" x1.75"	2
57	B20-00-0103	Harness-Engine Relays	1

DIESEL ENGINE ASSEMBLY (OPTIONAL)

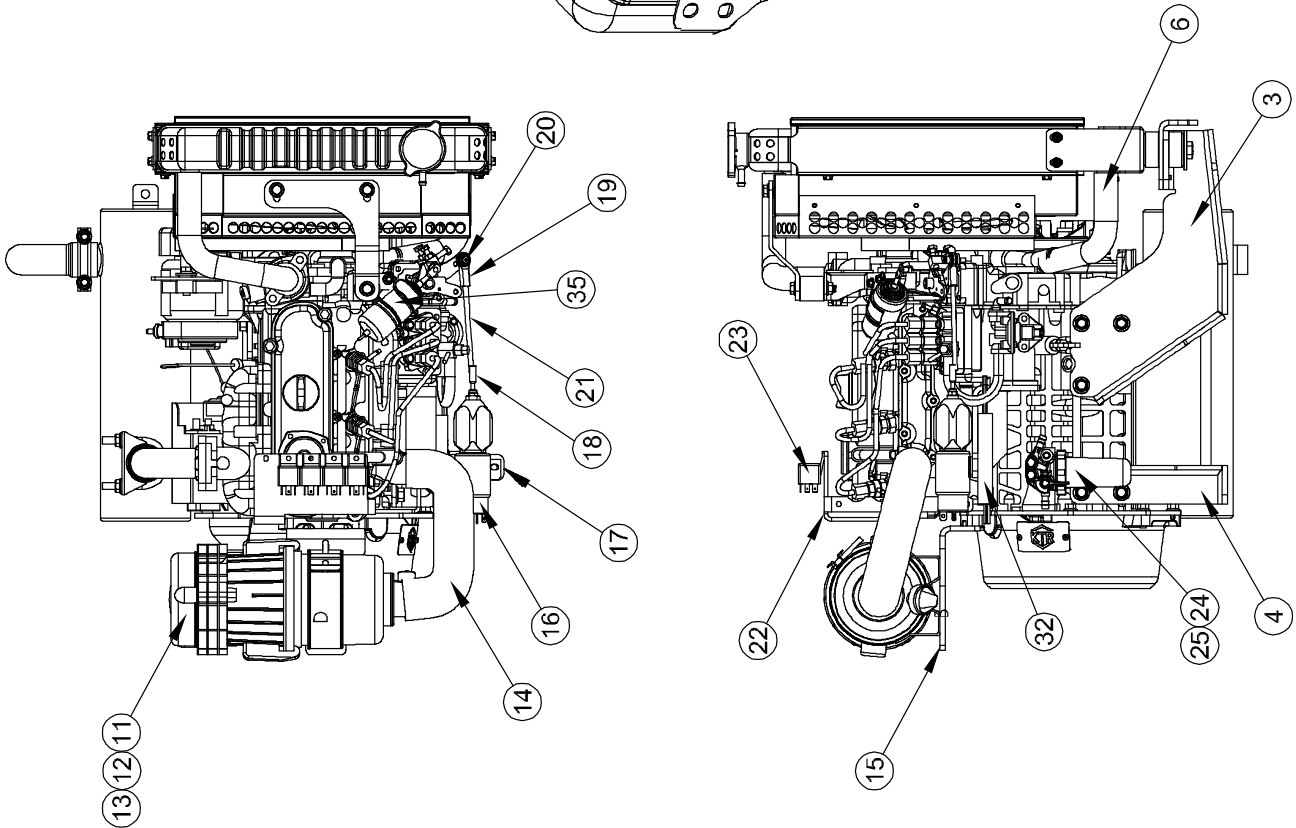
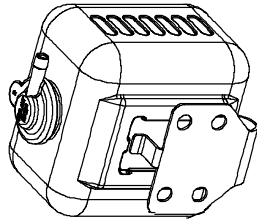
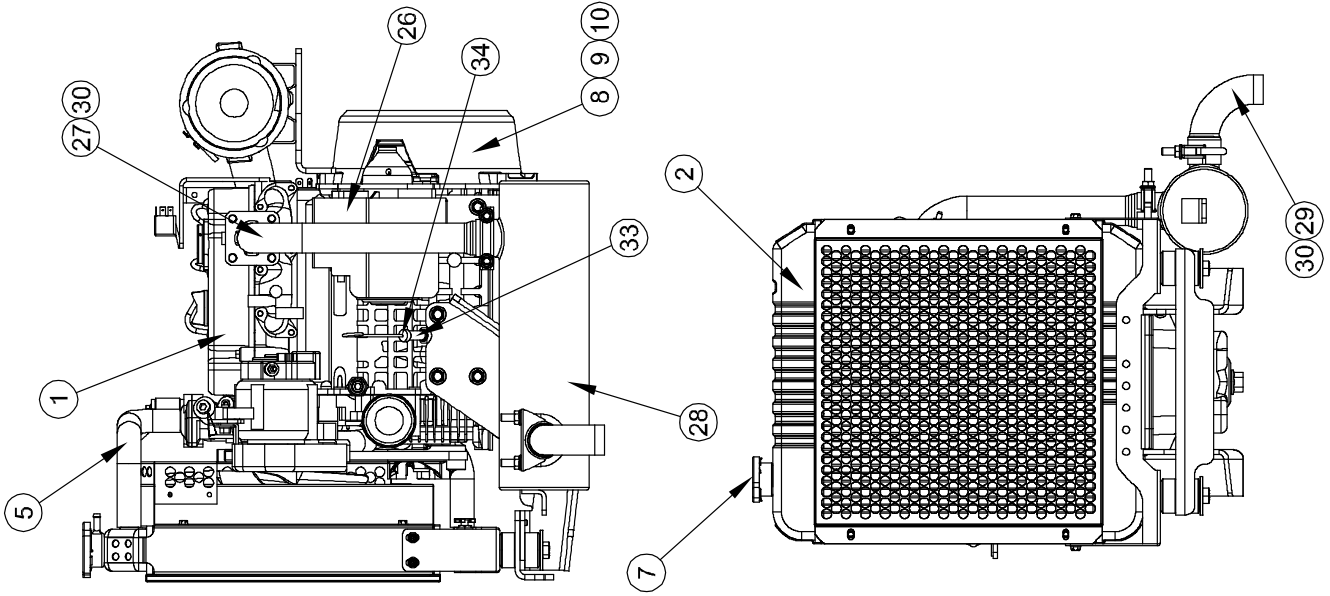

DIESEL ENGINE ASSEMBLY PARTS LIST

Item No.	Part No.	Description	Qty.
1	A-02061	Diesel Engine-Kubota (Model # D902E-1)	1
2	B20-00-0036	Radiator	1
3	B20-00-0037	Radiator Mount Kit	1
4	B20-00-0038	Rear Leg Kit	1
5	B20-00-0039	Radiator Upper Hose	1
6	B20-00-0040	Radiator Lower Hose	1
7	B20-00-0041	Radiator Cap	1
8	B20-00-0064	Drive Flange Disc	1
9	B20-00-0065	Drive Hub B Spline 15T	1
10	B20-00-0063	Pump Mount Housing SAE B	1
11	B20-00-0027	Air Cleaner Assembly	1
12	B20-00-0028	Air Cleaner Element-Outer	1
13	B20-00-0029	Air Cleaner Element-Inner	1
14	B20-00-0104	Intake Hose	1
15	B20-00-0091	Air Cleaner Mounting Bracket	1
16	B20-00-0044	Solenoid - 2 Speed	1
17	B20-00-0105	Mount Bracket - 2 Speed Solenoid	1
18	B20-00-0096	Inline Swivel	1
19	B20-00-0106	Rod End	1
20	B20-00-0107	Shoulder Bolt	1
21	B20-00-0108	¼-20 x 4.5" all Thread	1
22	B20-00-0093	Relay Bracket	1
23	B01-06-0060	Relay-24V 50 Amp	4
24	B20-00-0068	Fuel Filter Assembly	1
25	B20-00-0069	Fuel Filter Element	1
26	B20-00-0066	Starter Heat Shield	1
27	B20-00-0032	Exhaust Pipe W/Flange	1
28	B01-06-0030	Muffler	1
29	B20-00-0033	Tail Pipe 90 Degree	1
30	B20-00-0103	Clamp-Exhaust 3/8" x1.75"	2
31		Harness-Engine Relays(Diesel)	1
32	B20-00-0084	Coil Commander	1
33	B20-00-0109	Guide - Dipstick	1
34	B20-00-0110	Dipstick	1
35	B20-00-0073	Solenoid Engine Stop	1

DIESEL ENGINE ASSEMBLY (CONTINUED)

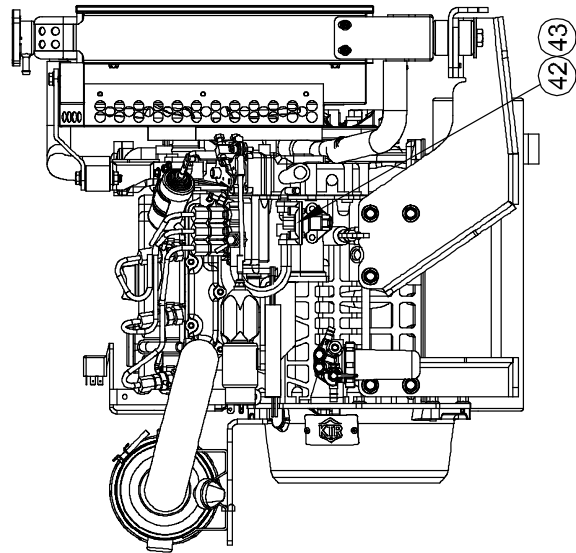
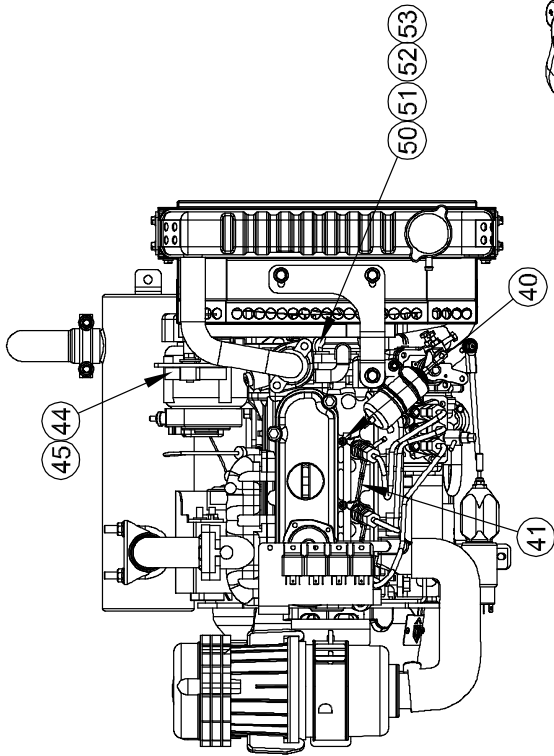
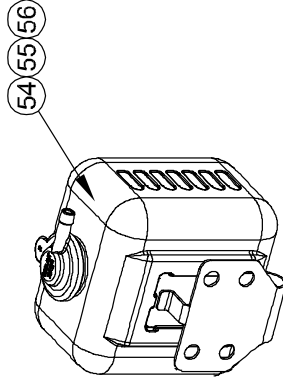
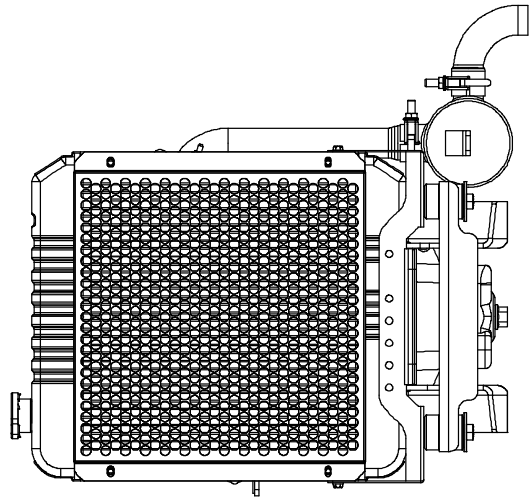
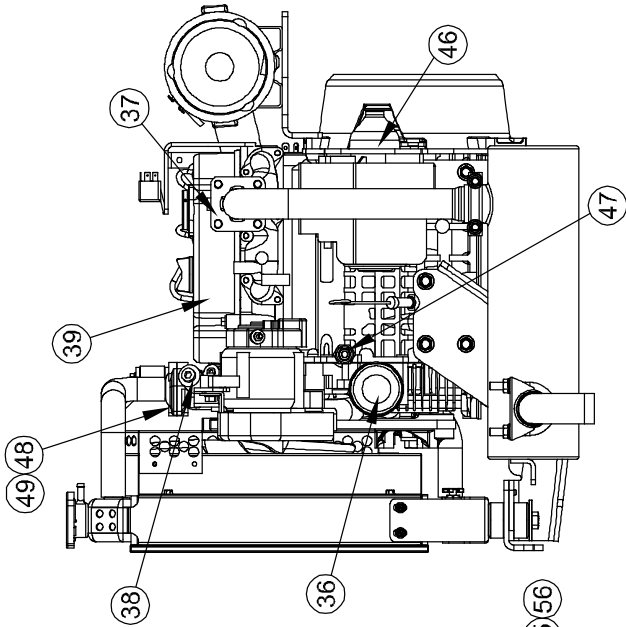

DIESEL ENGINE ASSEMBLY PARTS LIST (CONTINUED)

Item No.	Part No.	Description	Qty.
36	B20-00-0024	Oil Filter Replacement	1
37	B20-00-0031	Exhaust Gasket	1
38	B20-00-0043	Temperature Switch	1
39	B20-00-0048	Valve Cover Gasket	1
40	B20-00-0076	Glow Plugs	3
41	B20-00-0077	Fuel Overflow Pipe	1
42	B20-00-0078	Fuel Pump-Mechanical	1
43	B20-00-0079	Fuel Pump- Gasket	1
44	B20-00-0053	Alternator	1
45	B20-00-0054	Alternator Stay	1
46	B20-00-0080	Starter	1
47	B20-00-0056	Oil Pressure Switch	1
48	B20-00-0081	Thermostat	1
49	B20-00-0058	Thermostat Gasket	1
50	B20-00-0082	Water Pump	1
51	B20-00-0060	Water Pump Gasket	1
52	B20-00-0061	Fan-Pusher	1
53	B20-00-0062	Fan Belt	1
54	B20-00-0042	Coolant Overflow Bottle	1
55	B20-00-0100	Hose(Radiator-Overflow Bottle)(13")	1
56	B20-00-0101	Hose(Overflow Bottle-Base)(30")	1

HYDRAULIC COMPARTMENT ASSEMBLY

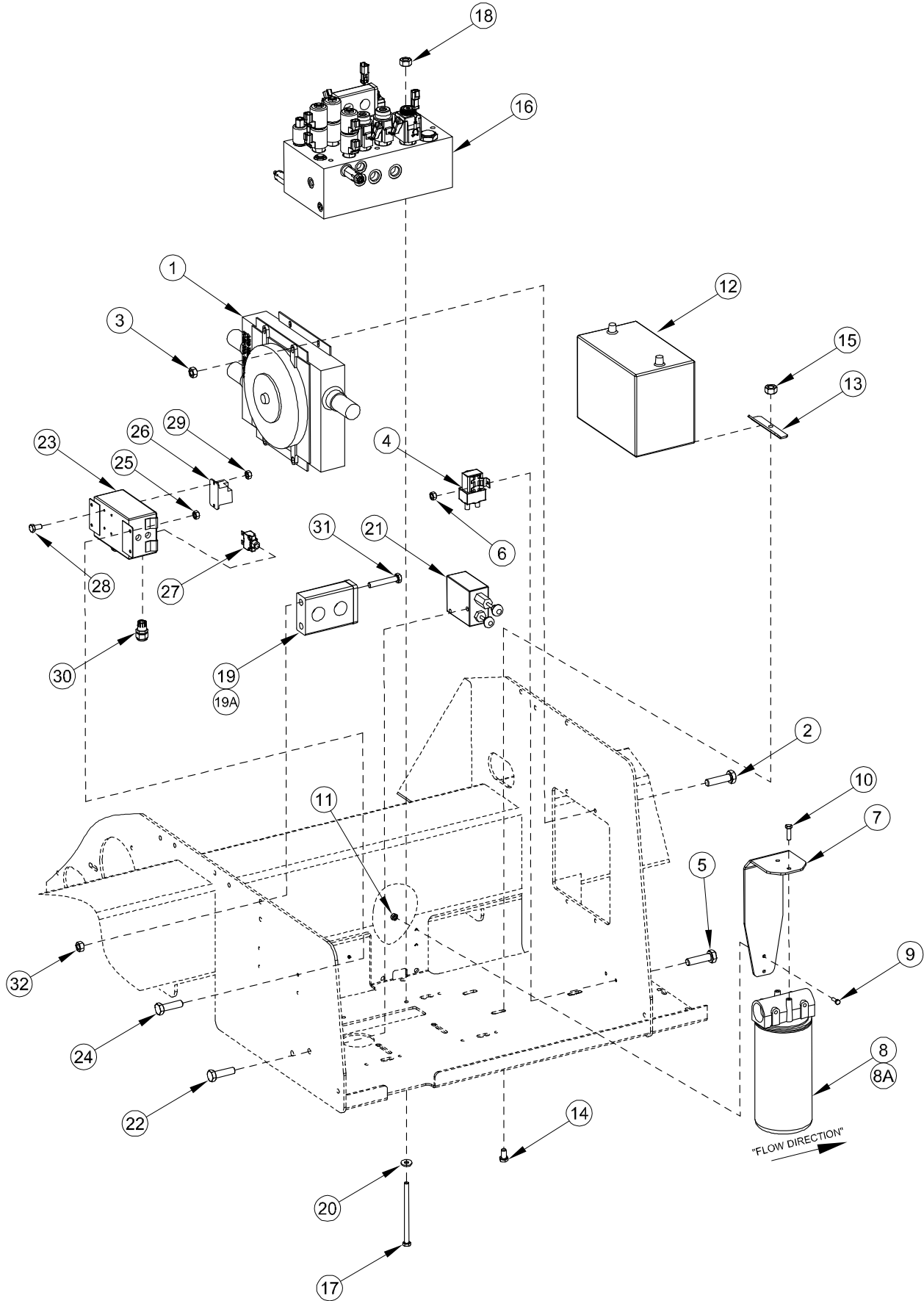

HYDRAULIC COMPARTMENT ASSEMBLY PARTS LIST

Item No.	Part No.	Description	Qty.
1	A-02069	Oil Cooler	1
2	0096-0010	Screw-HHCS-M8x20	4
3	0096-0040	Nut-Lock-M8	4
4	B01-06-0058	Contactora-24V DC	1
5	0096-0125	Screw-HHCS-M5x16	2
6	0096-0126	Nut-Lock-M5	2
7	A-02033	Filter Bracket	1
8	A-02070	Filter Assy	1
8A	B02-00-0084	Replacement Filter	1
9	0090-0028	Screw-Cap-5/16-18x3/4	2
10	0096-0002	Screw-HHCS-M6x20	2
11	0096-0039	Nut-Lock-M6	2
12	B01-04-0004	Battery 12V	1
13	A-02032	Battery Clamp	2
14	0096-0016	Screw-HHCS-M10x25	2
15	0096-0041	Nut-Lock-M10	2
16	A-02063	Drive Manifold (Refer to Page 96)	1
17	0096-0180	Screw-HHCS-M10x150	3
18	0096-0041	Nut-Lock-M10	3
19	B04-07-0143	Clamp Type	4
19A	B04-07-0144	Cover Plate	1
20	0096-0093	Washer-Flat-M10	3
21	A-01038	Pump-Hand-Brake Release	1
22	0090-0040	Screw-Cap-3/8-16x3/4	2
23	A-02015	Switcher Box	1
24	0096-0002	Screw-HHCS-M6x20 (Switcher Box)	4
25	0096-0039	Nut-Lock-M6	4
26	B01-06-0059	Relay-20 Amp	2
27	B01-10-0354	Circuit Breaker-20 Amp	2
28	0096-0112	Screw-HHCS-M4x12	4
29	0096-0076	Nut -Lock-M4	4
30	B01-09-0029	Cord Grip Plastic	4
31	0096-0095	Bolts-M10x130	2
32	0096-0041	Nut-Lock-M10	2

CONTROL COMPARTMENT ASSEMBLY

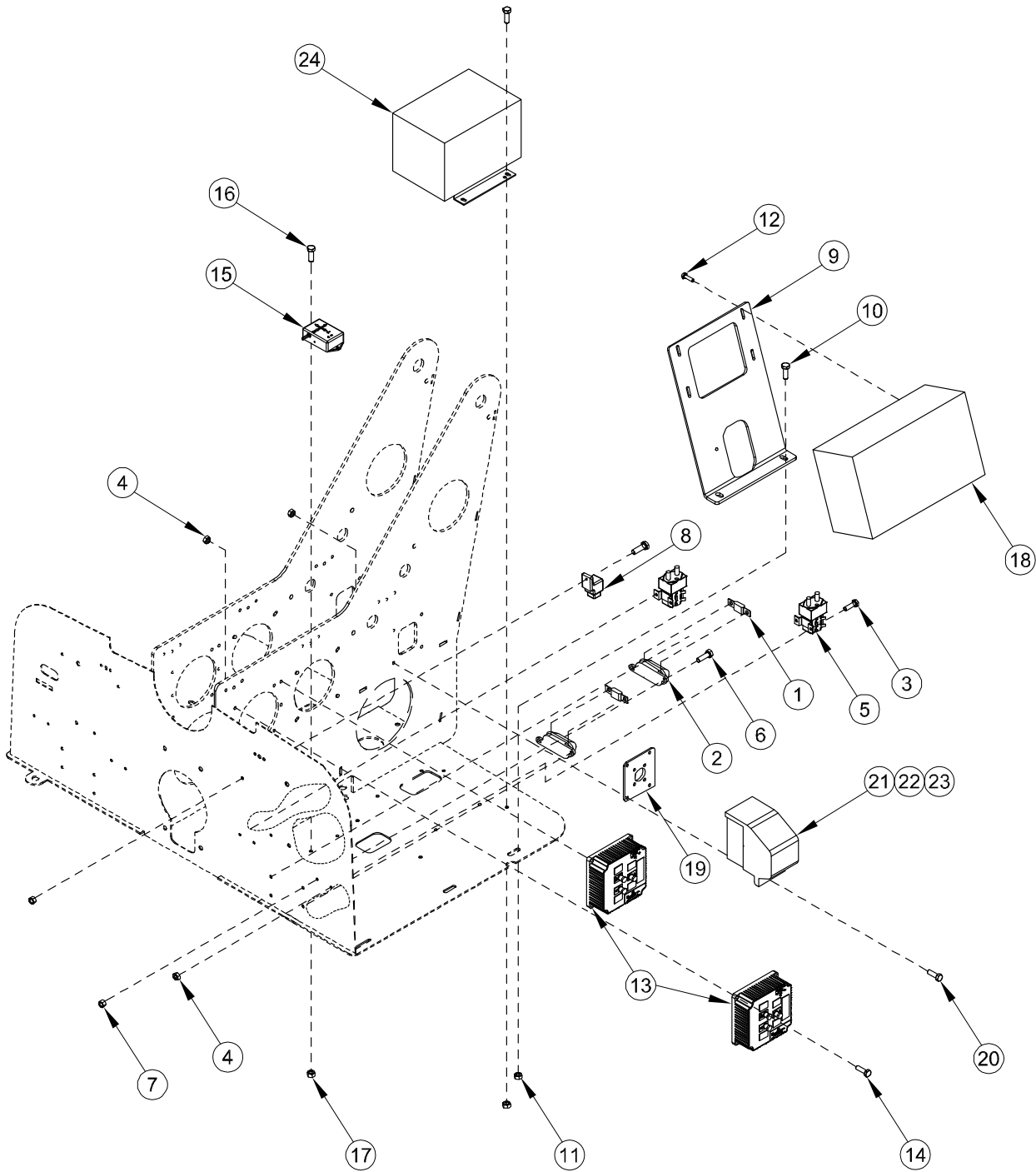

CONTROL COMPARTMENT ASSEMBLY PARTS LIST

Item No.	Part No.	Description	Qty.
1	B01-10-0330	Fuse 200 Amp	2
2	B01-10-0331	Fuse Holder-200 Amp	2
3	0096-0001	Screw-HHCS-M6x16	4
4	0096-0039	Nut-Lock-M6	15
5	B01-06-0058	Contactator-24V DC	2
6	0096-0125	Screw-HHCS-M5x16	4
7	0096-0126	Nut-Lock-M5	4
8	B01-06-0053	Relay-24 VDC 20 A	2
9	A-02233	Lower Control Mount	1
10	0096-0016	Screw - HHCS - M10x25	2
11	0096-0041	Nut-Lock-M10	2
12	0096-0001	Screw-HHCS-M6x16	4
13	A-00297	Motor Controller	2
14	0096-0131	Screw-HHCS-M6x30	4
15	A-00295	Level Sensor-5 Deg 0-5v	1
16	0096-0113	Screw-HHCS-M4x16	2
17	0096-0073	Nut-Lock-M4	2
18	A-03546	Lower Control Box	1
19	A-00287	Mount Plate-GFI	1
20	0096-0002	Screw-HHCS-M6x20	7
21	B01-10-0046	Box-Weather Tite	1
22	B-01-10-0034	Receptacle-GFI	1
23	A-00288	Plastic Cover	1
24	B-01-05-0056	Charger-Battery-24 Volt/40 Amp	1

TRIANGLE WELDMENT ASSEMBLY

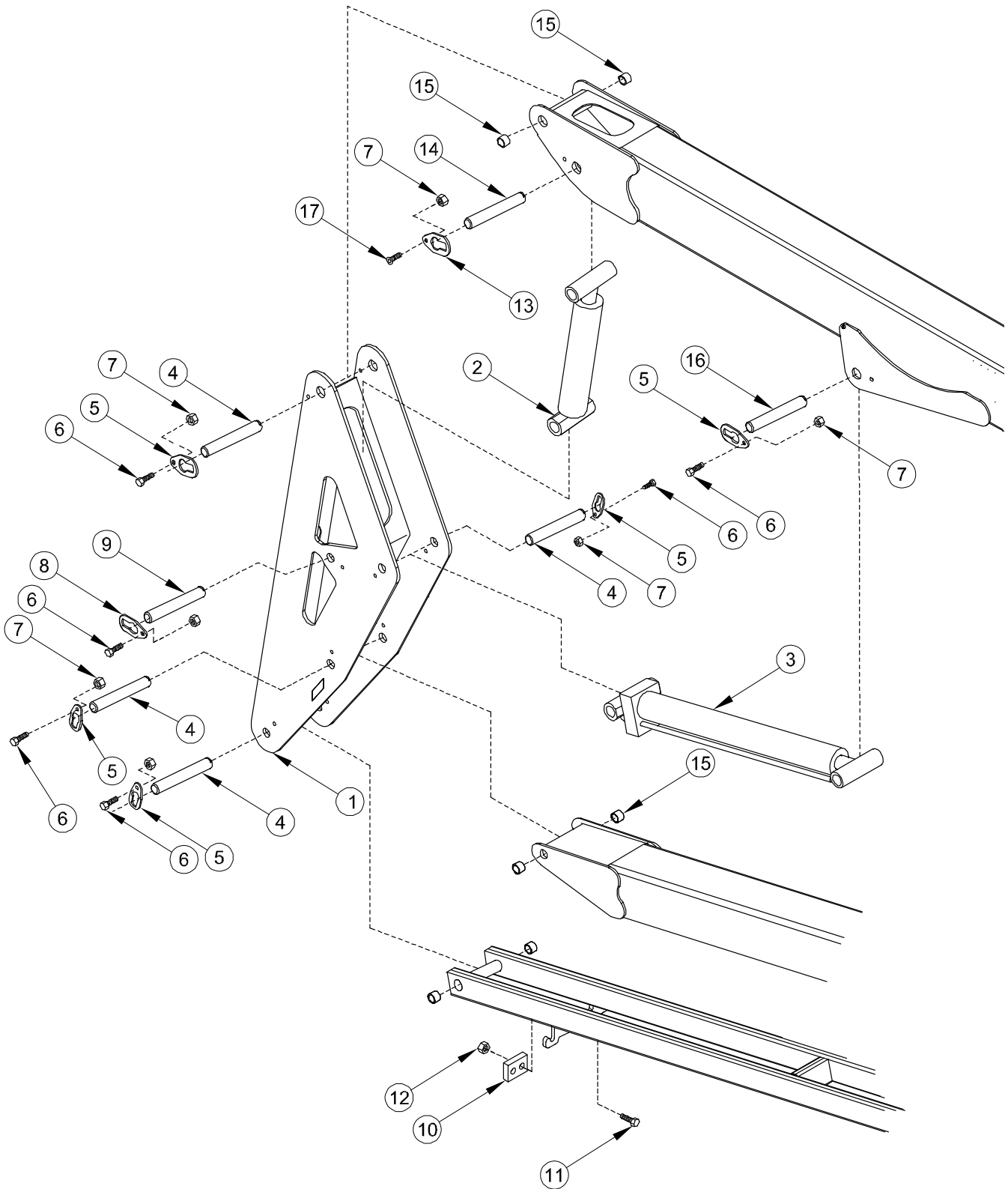

TRIANGLE WELDMENT ASSEMBLY PARTS LIST

Item No.	Part No.	Description	Qty.
1	A-02320	Triangle Weldment	1
2	A-01552	Master Cylinder	1
3	A-02551	Lift Cylinder	1
4	A-00021	Pin,-1.25 x 8.5	4
5	A-00019	Pin Retainer,-1.25	7
6	0096-0016	Screw-HHCS-M10 x25	8
7	0096-0041	Nut-Lock-M10	9
8	A-00018	Pin Retainer,-1.0	1
9	A-00049	Pin,-1.0 x8.5	1
10	A-00537	Switch Block	1
11	0096-0049	Screw-HHCS-M8 x45	2
12	0096-0040	Nut -Lock-M8	2
13	A-00054	Pin Retainer,-1.0 FH	1
14	A-00051	Pin,-1.0 x7.0, DB	1
15	A-00032	Bearing	6
16	A-00059	Pin,-1.25 x7.25	1
17	0096-0091	Screw-FHCS-M10x25	1

UPPER BOOM ASSEMBLY

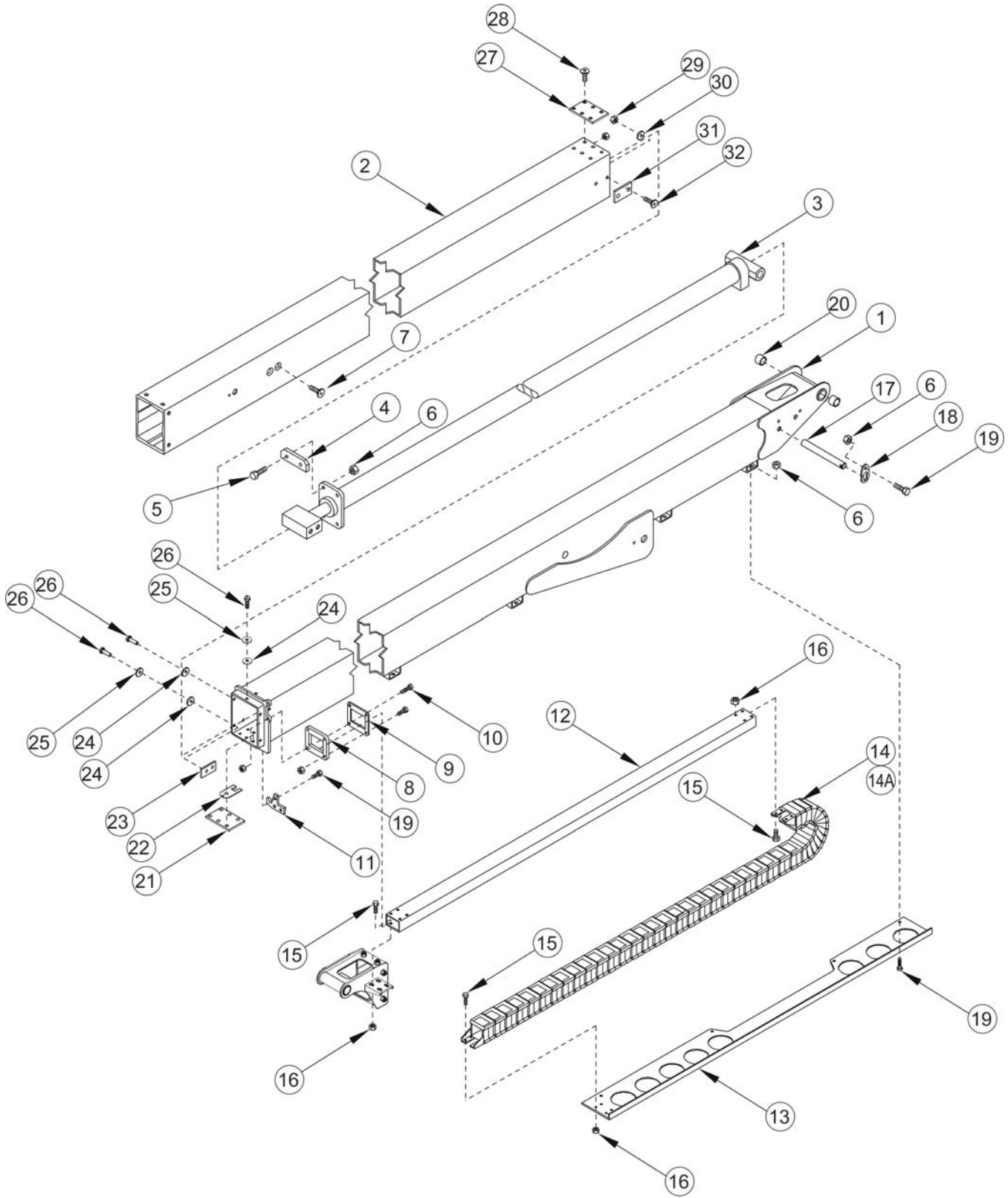

UPPER BOOM ASSEMBLY PARTS LIST

Item No.	Part No.	Description	Qty.
1	A-02502	Upper Boom Weldment	1
2	A-02510	Telescopic Boom Tube	1
3	A-02550	Extension Cylinder	1
4	A-00535	Slider	2
5	0096-0017	Screw-HHCS-M10x30	4
6	0096-0041	Nut-Lock-M10	16
7	0096-0033	Screw-FHCS-M16x35	4
8	A-00532	Tube Slider	1
9	A-00529	Tube Slider Back	1
10	0096-0018	Screw-HHCS-M10x40	4
11	A-01554	Boom Latch Hook	1
12	A-02531	Cable Track Tube	1
13	A-02536	Cable Track Tray	1
14	A-02530	Cable Track, Dual Piece Mounting, Both Ends (Prior to June 2010)	1
14A	A-02520	Cable Track, Single Piece Mounting, Both Ends (June 2010 onwards) . Also uses: 0096-0012 M8 x 25 Flat Head Cap Screw (Qty of 2) to attach to Item 13	
15	0096-0010	Screw-HHCS-M8x20 (Qty used decreases by 6 when Item 14A is used)	18
16	0096-0040	Nut-Lock-M8 (Qty used decreases by 4 when Item 14A is used)	18
17	A-00035	Pin,-0.75 x 6.5	1
18	A-00034	Pin Retainer,-0.75	1
19	0096-0016	Screw-HHCS-M10x25	8
20	A-00032	Bearing	4
21*	A-00542	Wear Pad Front Bottom	1
22*	A-00534	Wear Pad Shim	4
23*	A-00533-2	Wear Pad Boom Gray	4
24*	0096-0047	Washer-Nylon	14
25*	0096-0119	Washer-Flat-M10 Standard	10
26*	0096-0132	Screw-HHCS-M10x16 Alum	14
27+	A-00540	Wear Pad Top Rear	2
28+	0096-0006	Screw-FHSCS-M6x25	12
29+	0096-0039	Nut Lock-M6	12
30+	0096-0077	Washer Flat-M6	12
31+	A-00541	Wear Pad Side	2
32	0096-0003	Screw-FHSCS -M6x20	4

* B22-00-0069 Outer Wear Pad Kit (Includes Items 21-26).

+ B22-00-0070 Inner Wear Pad Kit (Includes Items 27-31).

JIB BOOM ASSEMBLY

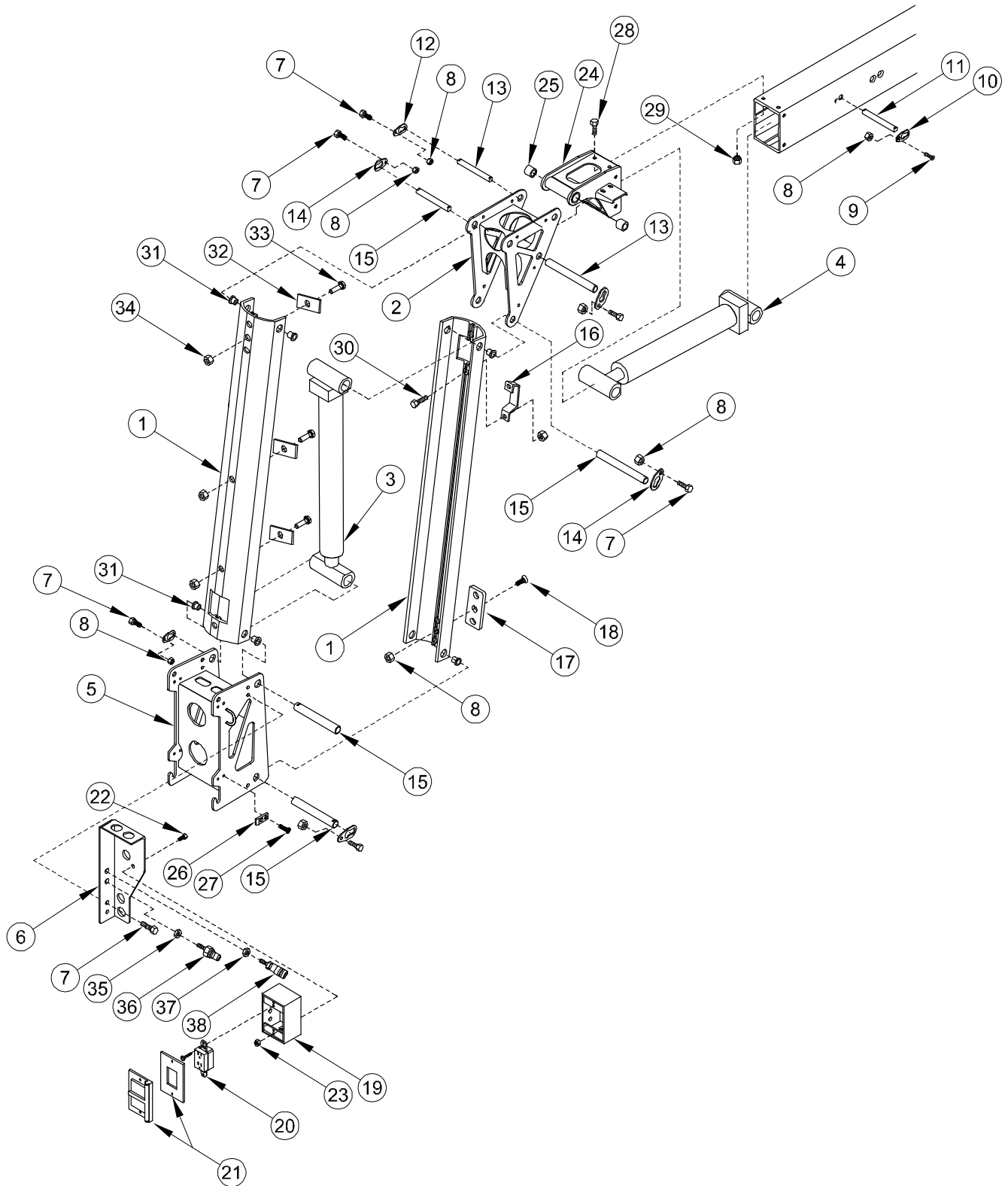

JIB BOOM ASSEMBLY PARTS LIST

Item No.	Part No.	Description	Qty.
1	A-00657	Jib Link Weldment	2
2	A-00651	End Pivot Weldment	1
3	A-00660	Jib Cylinder	1
4	A-01553	Slave Cylinder	1
5	A-00662	Jib End Weldment	1
6	A-01979	Bulkhead	1
7	0096-0016	Screw-HHCS-M10 x 25	7
8	0096-0041	Nut-Lock-M10	12
9	0096-0091	Screw-FHCS-M10 x 25	2
10	A-00054	Pin Retainer,-1.0-Flat Head	2
11	A-00052	Pin,-1.0x5.25	1
12	A-00018	Pin Retainer,-1.0	2
13	A-00061	Pin, -1.0 x7.375	2
14	A-00925	Pin Retainer,-0.75	4
15	A-00050	Pin,-0.75 x7.375	4
16	A-00674	Valve Guard	1
17	A-00667	Jib Bumper	1
18	0096-0068	Screw-FHCS-M10 x45	5
19	B01-10-0046	Outlet Box	1
20	B01-10-0034	GFI Outlet	1
21	B01-10-0392	Outlet Box Cover	1
22	0096-0001	Screw-HHCS-M6 x16	2
23	0096-0039	Nut-Lock-M6	10
24	A-00522	Boom End Weldment	1
25	A-00031	Bearing	2
26	A-00038	Ramp	4
27	0096-0002	Screw-FHCS-M6x20	8
28	0096-0019	Screw-HHCS-M12x25	8
29	0096-0042	Nut-Lock-M12	8
30	0096-0018	Screw-HHCS-M10x40	2
31	A-00056	Bearing, 0.75 ID x 0.5 Long	8
32	A-00669	Jib Hose Clamp	3
33	0096-0100	Screw-HHCS-M6x35	3
34	0096-0036	Nut-Lock-M6	3
35	B09-00-0052	#4MJIC-#4MNPT Str Bulkhead	1

JIB BOOM ASSEMBLY (CONTINUED)

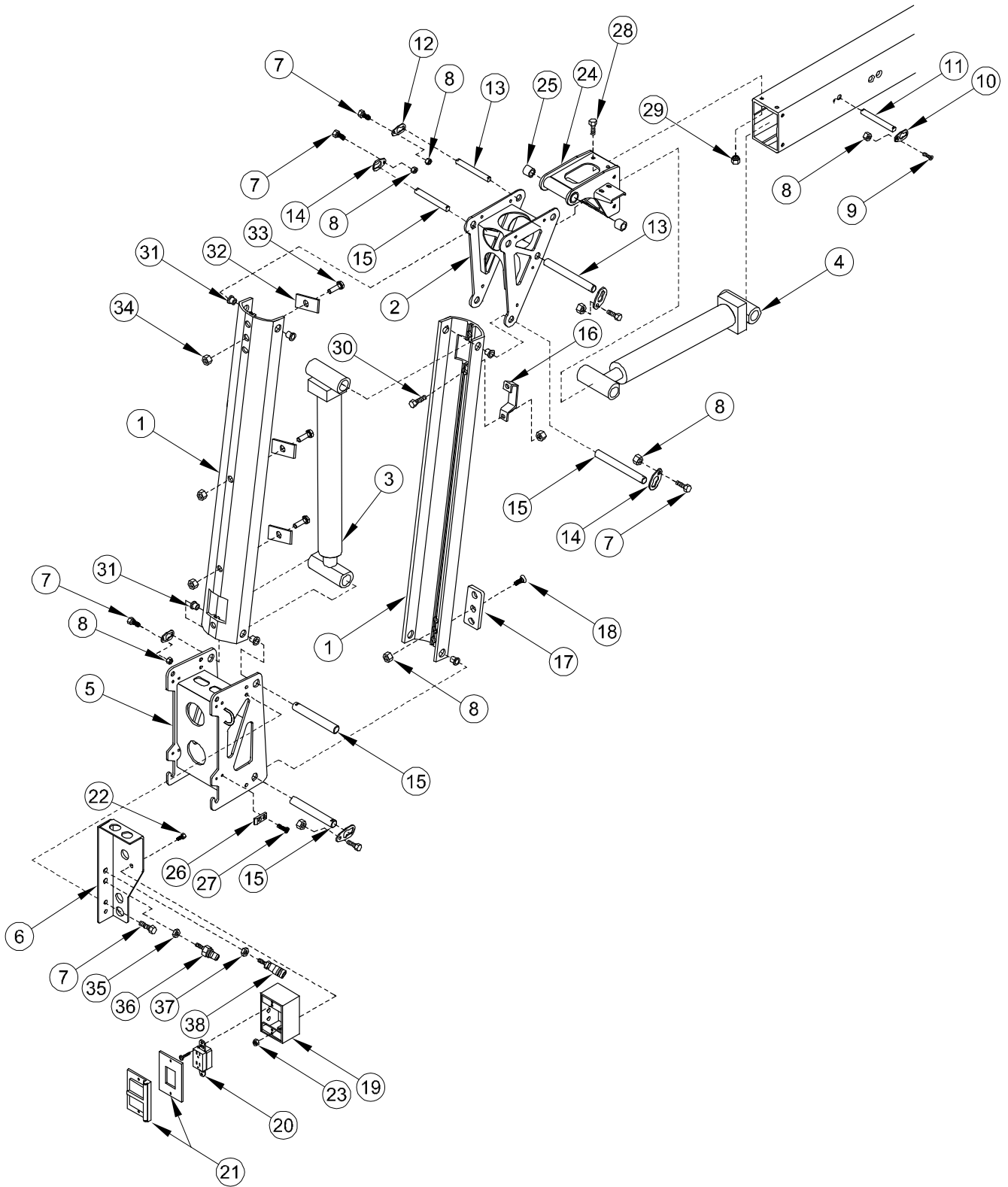

JIB BOOM ASSEMBLY PARTS LIST (CONTINUED)

Item No.	Part No.	Description	Qty.
36	B09-00-0054	#4 QD Coupler-#4 FMNPT	1
37	B09-00-0058	#6MJIC-#6MNPT Str Bulkhead	1
38	B09-00-0057	#6 QD Nipple-#6FMNPT	1

PLATFORM ASSEMBLY

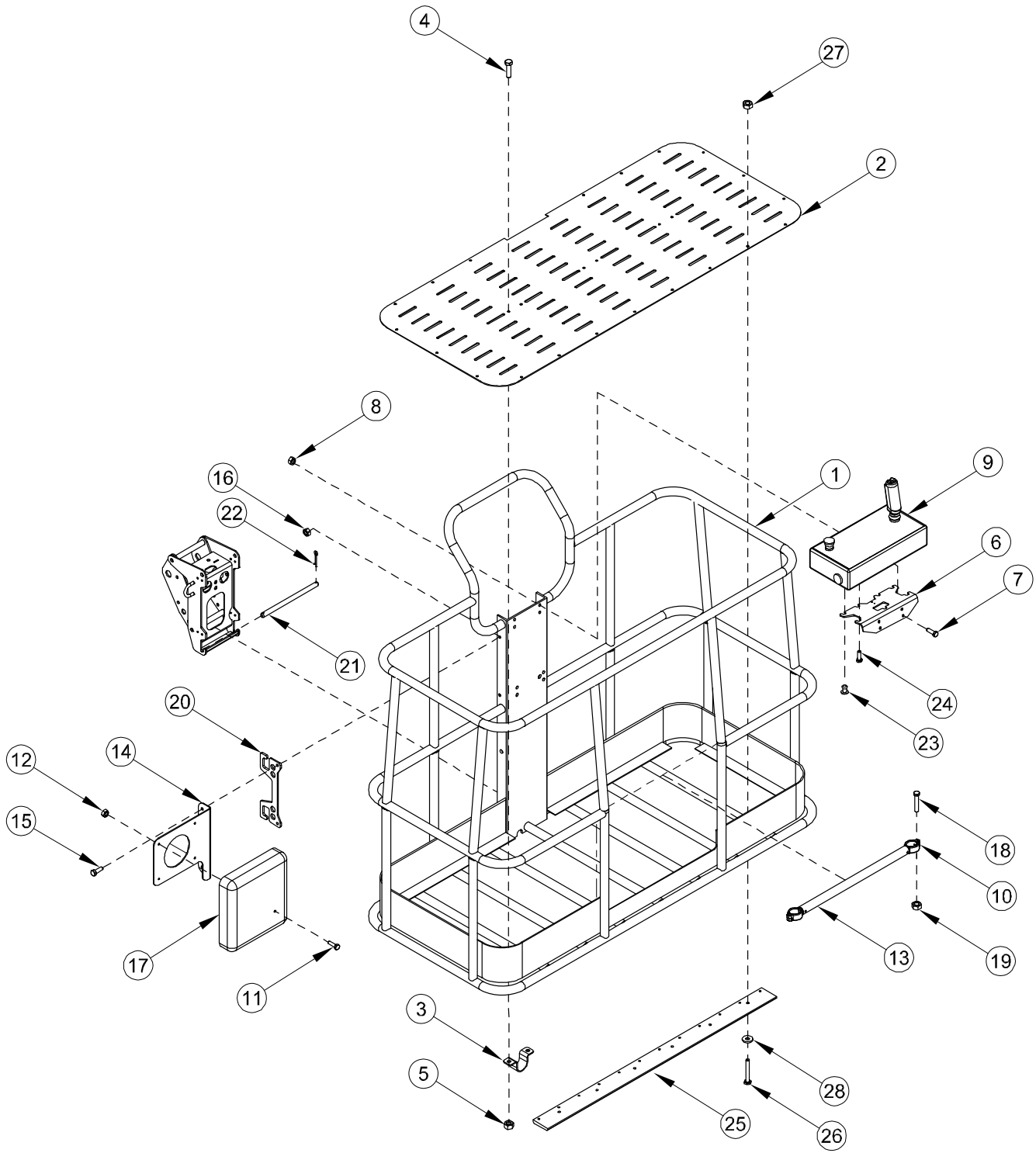

PLATFORM ASSEMBLY PARTS LIST

Item No.	Part No.	Description	Qty.
1	A-03350	Platform Weldment-5 Ft Plt	1
2	A-03359	Platform Bottom 5ft	1
3	A-03376	Clamp-Conduit-Rigid-2 Hole Drilled	3
4	0096-0102	Screw-BHCS- M8 x25mm-gr8.8	26
5	0096-0040	Nut-Lock- M8-Gr 8	26
6	A-03361	Upper Control Mount 5ft Platform	1
7	0096-0016	Screw- HHCS-M10x25mm-gr8.8	4
8	0096-0041	Nut-Lock-M10-Gr 8	4
9	A-03545	Platform Control Box	1
10	A-00463	Platform Midrail End-cage	4
11	0096-0052	Screw-HHCS-M6x40mm-gr8.8	2
12	0096-0039	Nut-Lock- M6-Gr 8	4
13	A-00464	Midrail Tube Boom Cage	1
14	A-00468	Manual Mount Plate	1
15	0096-0017	Screw- HHCS-M10 X 30mm-gr8.8	2
16	0096-0041	Nut-Lock-M10-Gr 8	2
17	A-00475	Manual Storage Box-gasketed	1
18	0096-0001	Screw- HHCS- M6 x16mm-Gr8.8	4
19	0096-0039	Nut-Lock- M6-Gr 8	4
20	A-00474	Cord Wrap Bracket	1
21	A-00071	Pin-platform-.5 x8.875	1
22	0090-0147	Pin-cotter-1/8 x1 1/4-zinc	2
23	0090-0679	Rivet-pop-5/32 x.250 Grip	2
24	0096-0115	Screw- SHCS-M6 x20mm-gr8.8	2
25	A-00488	Skid Pad-articulating Booms	1
26	0096-0080	Screw-FHCS-M8x70mm-gr8.8	4
27	0096-0040	Nut-Lock- M8-Gr 8	4
28	0090-0420	Washer-SAE-flat- 5/16-zinc	4

JOYSTICK ASSEMBLY

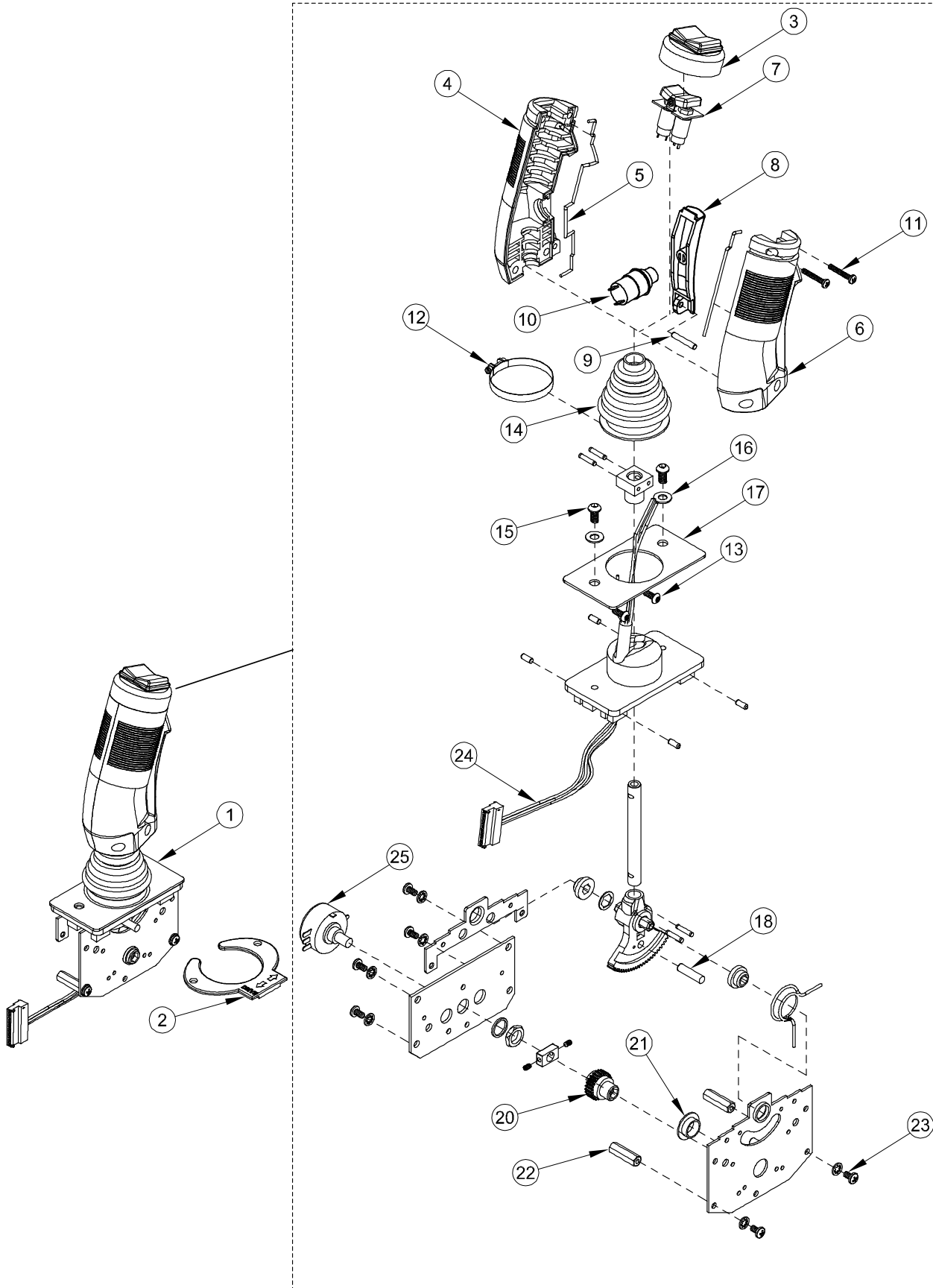

JOYSTICK PARTS LIST

Item No.	Part No.	Description	Qty.
1	B01-10-370	Joystick	1
2	B01-10-318	Plate, Drive Direction	1
3	B01-10-0311	Rubber Cup, Thumb Switch	1
4	B01-10-0312-1	Handle, Joystick, Left Half	1
5	B01-10-0313	Rubber Cord	2
6	B01-10-0312-2	Handle, Joystick, Right Half	1
7	B01-10-0315	Switch, Thumb Actuator	1
8	B01-10-0314	Lever, Enable Switch	1
9	B01-10-0305	Pin, Dowel, 1/8 x ¼ in.	1
10	B01-10-0316	Pushbutton, Enable Switch	1
11	0090-0500	Screw, Machine #4-40 x ¾ in.	2
12	B01-10-0218	Clamp	1
13	B01-10-0217	Screw, Machine, Torx, #6-32 x 3/8 in.	2
14	B01-10-0210	Boot, Rubber	1
15	0090-0243	Screw, Machine, #10-32 x ½ in.	2
16	B01-10-0209	Washer, Plastic	2
17	B01-10-0208	Gasket, Foam	1
18	B01-10-0306	Pin, Dowel, 3/16 x ¼ in.	1
19	B01-10-0308	Spring, Torsion	1
20	B01-10-0307	Gear, 24 Tooth, Switch Activation	1
21	B01-10-0310	Bushing, Flanged	1
22	B01-10-0309	Standoff, Hex	2
23	0030-1087	Screw, Machine, Panhead, #6-32 x ¼ in.	2
24	B01-10-0393	Harness, Rocker/Lever Switch	1
25	B01-10-0394	Potentiometer W/Nut and Washer	1

DRIVE MANIFOLD ASSEMBLY

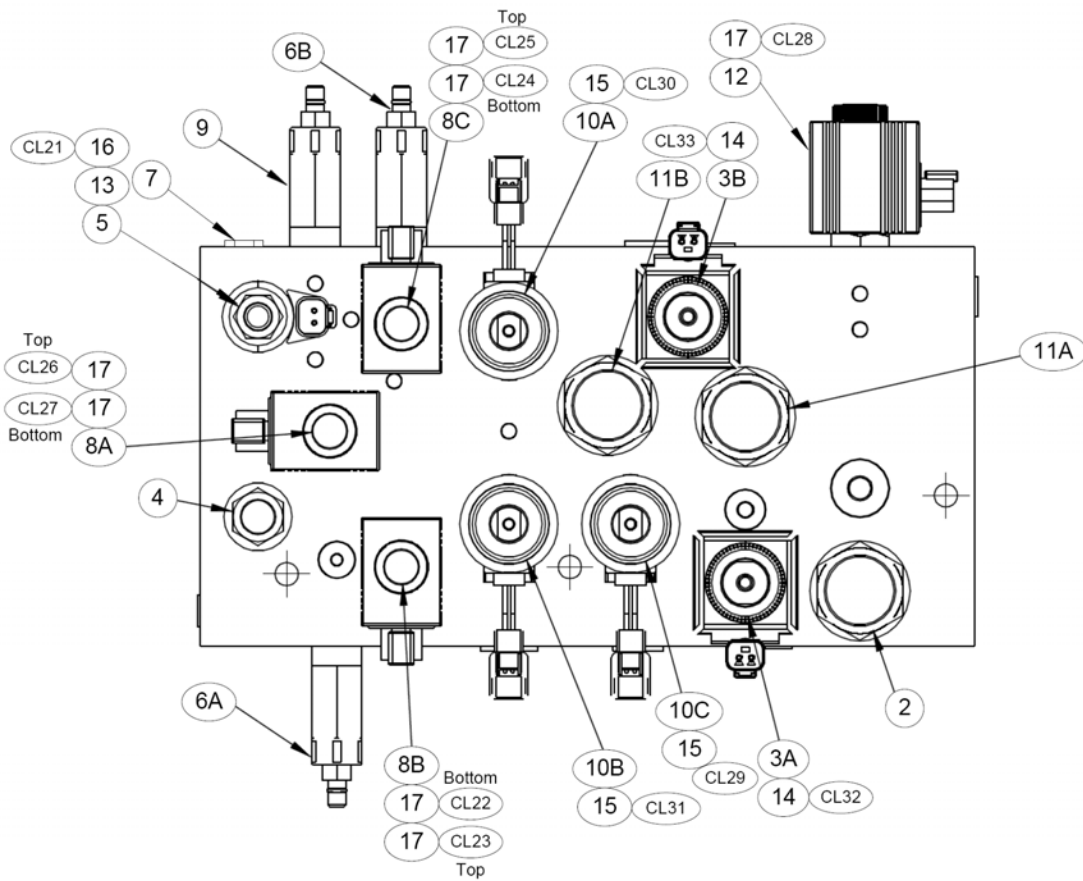
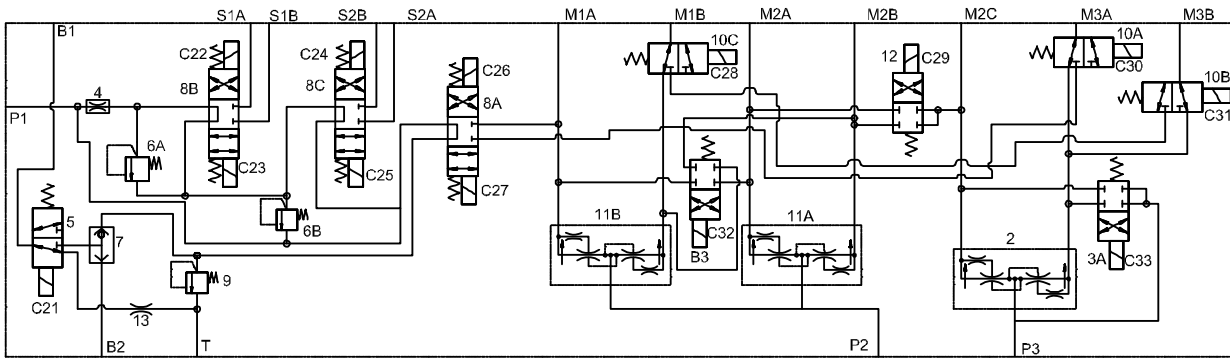

DRIVE MANIFOLD ASSEMBLY PARTS LIST

Item No.	Part No.	Description	Qty.
1	A-02063	Manifold Complete	1
2	B02-04-0125	Valve-Flow Divider Combiner	1
3A, 3B	B02-04-0126	Valve-Directional 4 Way-2 Position	2
4	B02-04-0127	Valve-Flow Regulator Set at 2.5gpm	1
5	B02-04-0128	Valve-Directional 3 Way-2 Position	1
6A	B02-04-0129	Valve-Relief (Set at 2400 PSI)	1
6B	B02-04-0130	Valve-Relief (Set at 1500 PSI)	1
7	B02-04-0131	Valve-Shuttle	1
8A, 8B, 8C	B02-04-0132	Valve-Directional 4 Way-3 Position	3
9	B02-04-0133	Valve-Relief (Set at 360PSI)	1
10A, 10B,10C	B02-04-0134	Valve-Directional 3 Way-2 Position	3
11A, 11B	B02-04-0135	Valve-Flow Divider Combiner	2
12	B02-04-0136	Valve-Directional 4 Way-2 Position	1
13	B02-04-0137	Orifice Disc (0.030")	1
14	B01-08-0026	Coil-24V W/Deutsch Conn (For Valves 3A & 3B)	2
15	B01-08-0027	Coil-24V W/Deutsch Conn (For Valves 10A,10B,10C)	3
16	B01-08-0028	Coil-24V W/Deutsch Conn (For Valve 5)	1
17	B01-08-0029	Coil-24V W/Deutsch Conn (For Valves 8A, 8B, 8C,12)	7

PUMP ASSEMBLY (A-02254HS) PARTS LIST

Item No.	Part No.	Description	Qty.
1	B02-15-0496	Manifold, Valve Housing	1
2	B02-14-0108	Valve, Cartridge (Telescope)	2
3	B02-15-0472	Manual Pump, Extend/Retract/Rotate	1
4	B02-14-0089	Valve, Cartridge (Outrigger Check)	1
5	B02-14-0109	Valve, Cartridge (Outrigger)	2
6	B02-14-0091	Valve, Check	1
7	B02-14-0110	Valve, Check	1
8	B02-14-0094	Valve, Proportional	1
9	B02-14-0095	Coil Sterling, Proportional Valve	1
10	B02-14-0111	Valve, Relief	1
11	B02-14-0097	Valve, Relief	1
12	B02-14-0098	Valve, Shuttle	1
13	B02-14-0099	Valve, Cartridge (Rotator)	1
14	B02-14-0100	Valve, Counterbalance	2
15	B02-14-0101	Valve, Cartridge (Basket Compensate)	1
16	B02-14-0	Valve, Flow Control (Rotator)	1
17	B02-02-0245	Fitting, Plug, #2 ORB	11
18	B02-02-0246	Fitting, Hex Plug	1
19	B02-02-0277	Fitting, Plug, #4 ORB	5
20	B02-14-0112	Coil, 20 VDC, #8	5
21	B02-14-0113	Coil, 20 VDC, #10	4
22	B02-15-0497	Stud, 1/4-20 x 5/8	4
23	B02-15-0498	Expansion Plug	1
24	B02-02-0283	Fitting, Plug, #6 ORB	2
25	B02-15-0478	Seal Ring	1

PUMP ASSEMBLY (A-02254HS) (CONTINUED)

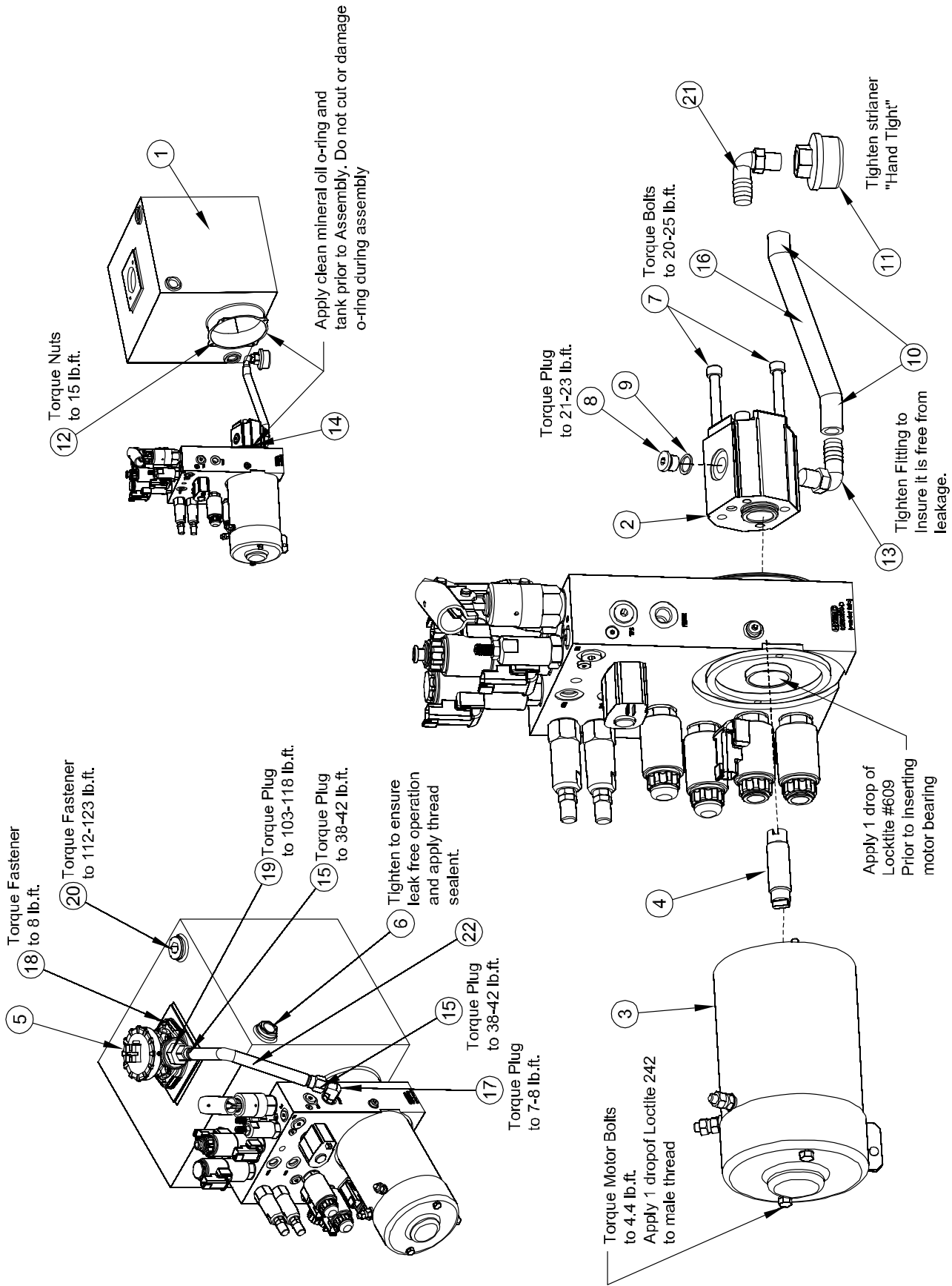

PUMP ASSEMBLY (A-02254HS) PARTS LIST (CONTINUED)

Item No.	Part No.	Description	Qty.
1	B02-15-0511	Reservoir	1
2	B02-15-0512	Pump Assembly, 3.15CCM	1
3	B02-15-0471	Motor, Pump, 24 V DC	1
4	B02-15-0500	Coupling, .875 x 2.795	1
5	B02-15-0501	Filter, Hydraulic	1
6	B02-15-0476	Sight Glass	1
7	B02-15-0509	Socket Head Cap Screw, M8 x 95	2
8	B02-02-0247	Fitting, Plug, M14 x 1.5 x 5.8	1
9	B02-15-0478	Seal Ring	1
10	B02-15-0485	Clamp, Band, #10-16	2
11	B02-15-0480	Filter, Suction, Pump	1
12	B02-15-0504	Allen Nut, 1/4-20	4
13	B02-02-0255	Fitting, M18 x HB-90 MxHB-90	1
14	B02-15-0503	O-Ring, 110.72 x 3.53 NBR 70D	1
15	B02-02-0279	Fitting, JIC-8 x Push On FsxPO	2
16	B02-15-0510	Hose, Black, 1/2 x 10"	1
17	B02-02-0280	Fitting JIC-8 x #6 90 MxM	1
18	B02-15-0506	Cap Screw, #5/16-18 x 1 1/4	2
19	B02-02-0278	Fitting, JIC-8 x G 3/4 MxM	1
20	B02-02-0281	Fitting, Plug, #12 ORB	2
21	B02-02-0282	Fitting, 3/8 NPT x 1/2 MxHB	1
22	B02-15-0507	Hose, Black, 1/2 x 15"	1

HYDRAULIC SCHEMATIC PARTS LIST

Item No.	Part No.	Description	Qty.
1	B02-15-0512	Pump-Gear 3.15cc/Rev	1
2	B02-15-0471	Motor-24VDC 3KW 3300rpm	1
3	B02-15-0472	Pump-Hand .5cc/pump	1
4	B02-14-0091	Valve-Check	1
5	B02-15-0480	Strainer-Suction	1
6	B02-15-0501	Filter & Housing	1
7	B02-00-0070	Filter-Replacement	1
8	B02-14-0094L	Valve-Prop	1
9	B02-14-0095	Coil-Prop	1
10	B02-14-0111	Valve-Relief(Set at 3000psi)	1
11	B02-14-0109	Valve-Outtrigger-Pump	1
12	B02-14-0113	Coil 20V DC	4
13	B02-14-0089	Valve-Check-Outtrigger-Pump	1
14	B02-14-0112	Coil 20V DC	5
15	B02-14-0110	Valve-Check-PO	1
16	B02-14-0099	Valve-Cart-Rotate	1
17	B02-14-0097	Valve-Relief (800psi)(Rotate)	1
18	B02-14-0114	Valve-Flow Control	1
19	B02-14-0098	Valve-Shuttle	1
20	B02-14-0108	Valve-Cart-Ext Cylinder	1
21	B02-14-0101	Valve-Cart-Basket Level	1
22	B02-14-0100	Valve-Counter Balance	1
23	B02-15-0511	Reservoir-5.6 gal capacity useable	1
24	A-02138	Cylinder-Outtrigger-4642 & 5533	1
24A	B02-13-0154	Seal Kit-For A-02138	1
25	B02-04-0118	Valve-Double Check	1
26	B01-08-0022	Coil-20V DC	8
27	B02-14-0087	Orifice disc - .037	1
28	A-02550	Cylinder -Extension 5533A	1
28A	B02-13-0164	Seal Kit - A-02550	1
29	B02-04-0105	Valve-Counter Balance(CABG-LHN)	1
30	B02-04-0106	Valve-Counter Balance(CBCA-LHN)	1
31	A-01552	Cylinder-Master	1
31A	B02-13-0150	Seal Kit - For A-01552 & A-01553	1
32	A-01553	Cylinder-Slave	1
33	B02-04-0095	Valve-Counter Balance(CABG-LHN)	1

HYDRAULIC SCHEMATIC (CONTINUED)

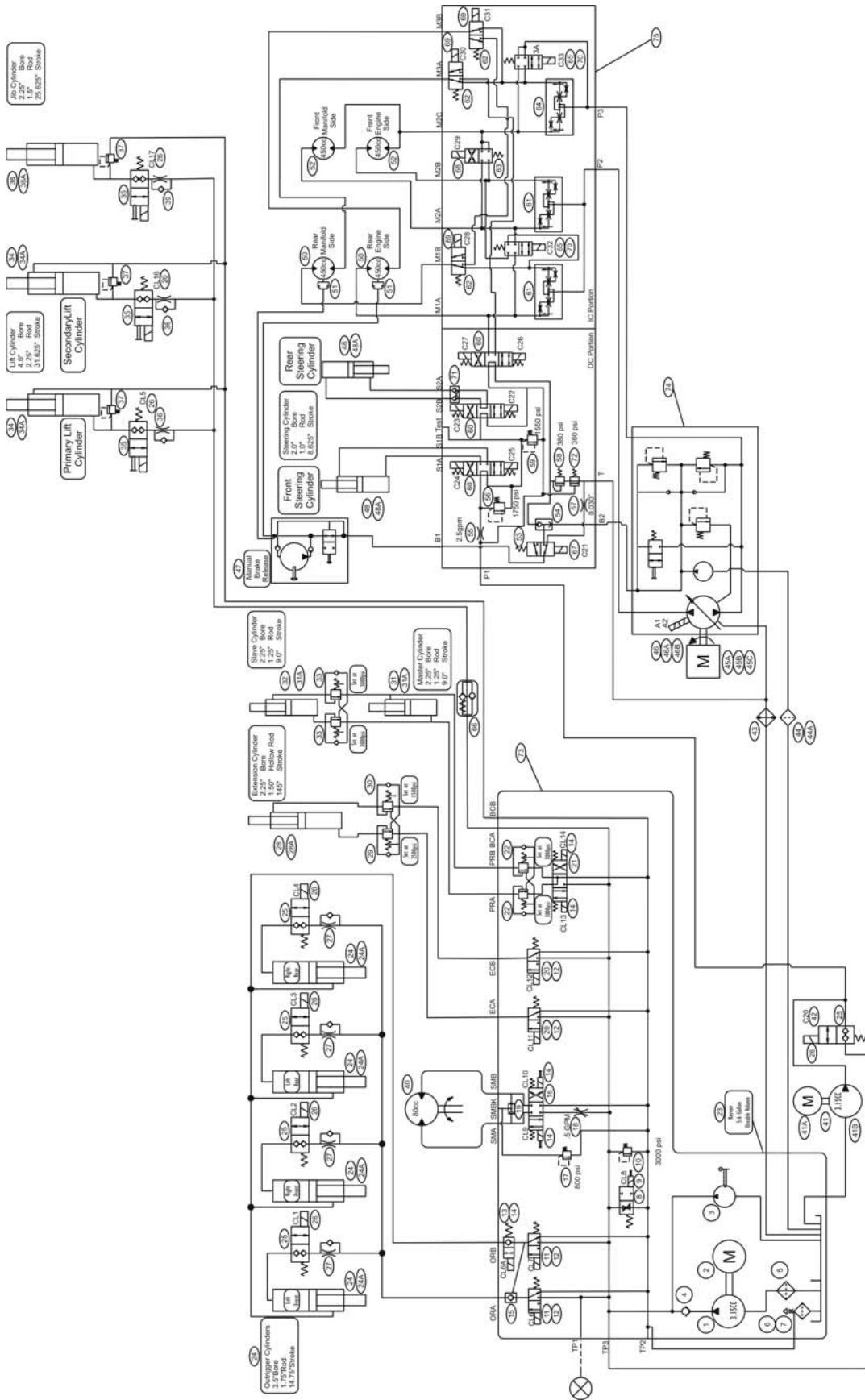

HYDRAULIC SCHEMATIC PARTS LIST (CONTINUED)

Item No.	Part No.	Description	Qty.
34	A-02551	Cylinder - Lift	1
34A	B02-13-0162	Seal Kit - For A-02551	1
35	B02-04-0119	Valve-Double Check W/Manual	1
36	B02-14-0106	Orifice .056	1
37	B02-04-0109	Relief-Thermal(set at 4000psi)	1
38	A-00660	Cylinder - Jib	1
38A	B02-13-0152	Seal Kit - For A-00660	1
39	B02-14-0104	Orifice .042	1
40	B02-06-0018	Slew Drive - 80CC	1
41	A-02235	Auxiliary Pump	1
41A	B02-15-0530	Pump-Gear 3.15 cc/Rev	1
41B	B02-15-0528	Motor-24Vdc-3KW-330 RPM	1
42	B02-04-0121	Valve Assembly-Double check	1
43	A-02069	Cooler-Oil	1
44	A-02070	Filter-Oil-Suction-Assembly	1
44A	B02-00-0084	Filter-Oil-Element Only(Suction)	1
45A	A-02060	Engine-Gas	1
45B	A-02061	Engine-Diesel	1
45C	A-02062	Engine-Gas/Propane	1
46	B02-04-0138	Valve-Directional/Proportional	1
46A	B01-08-0030	Coil Assembly(Includes Both Coils)	1
46B	B32-00-0020	Gasket(For valve Assembly)	1
47	A-01038	Pump-Hand-Brake Release	1
48	A-01030	Cylinder-Steering	1
48A	B02-13-0159	Seal Kit-For A-01030	1
49	B02-14-0124	Valve-Double PO Check	1
50	A-02064	Motor-Rear	1
51	A-02066	Brake	1
52	A-02065	Motor-Front	1
53	B02-04-0128	Valve-Directional 3way-2position	1
54	B02-04-0131	Valve-Shuttle	1
55	B02-04-0127	Valve-Flow Regulator (2.5gpm)	1
56	B02-04-0129	Valve-Relief (2400psi)	1
57	B02-04-0137	Orifice disc (0.030")	1
58	B02-04-0133	Valve-Relief (360psi)	1
59	B02-04-0130	Valve-Relief (1500psi)	1

HYDRAULIC SCHEMATIC PARTS LIST (CONTINUED)

Item No.	Part No.	Description	Qty.
60	B02-04-0132	Valve-Directional 4way-3position	1
61	B02-04-0135	Valve-Flow Divider Combiner	1
62	B02-04-0134	Valve-Directional 3way-2position	1
63	B02-04-0136	Valve-Directional 4way-2position	1
64	B02-04-0125	Valve-Flow Divider Combiner	1
65	B02-04-0126	Valve-Directional 4way-2position	1
66	B02-00-0066	Double Check valve	1
67	B01-08-0028	Coil-24V	1
68	B01-09-0029	Coil-24V	7
69	B01-08-0027	Coil-24V	3
70	B01-08-0026	Coil-24V	2
71	B02-04-0142	Valve-Dual Piloted Check	1
72	B02-04-0141	Valve-Pressure Sequence (380psi)	1
73	A-02254HS	Pump Unit (3.15cc/Rev)	1
74	A-02067	Pump Unit (37gpm)	1
75	A-02063	Manifold Assembly	1

BOOM AND ROTATION HYDRAULIC LINES

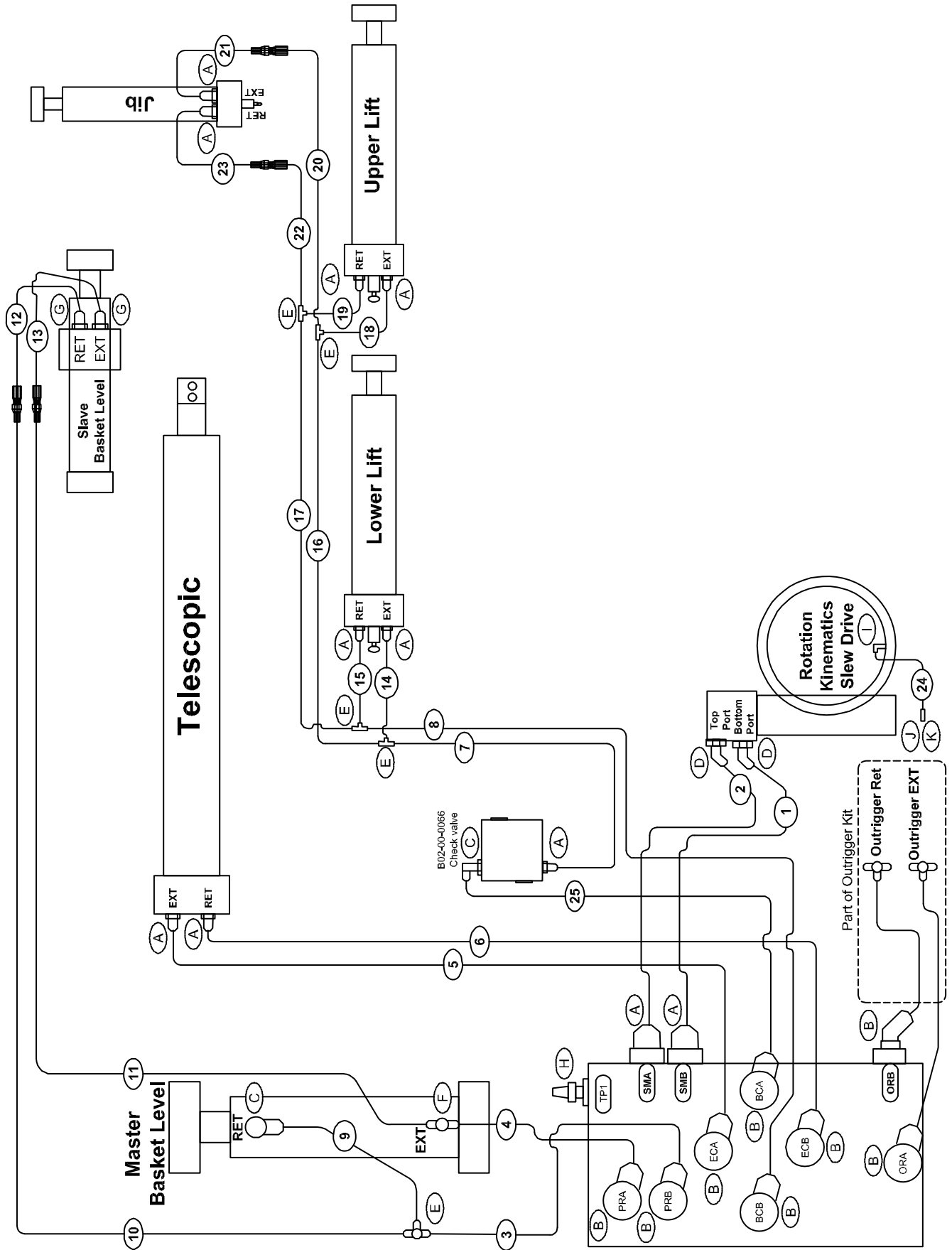

BOOM AND ROTATION HYDRAULIC LINES PARTS LIST

Item No.	Part No.	Description	Qty.
1	B02-01-0281	Hydraulic Hose - #4 x 36"	1
2	B02-01-0280	Hydraulic Hose - #4 x 36 "	1
3	B02-01-0302	Hydraulic Hose - #4 x 240 "	1
4	B02-01-0303	Hydraulic Hose - #4 x 240 "	1
5	B02-01-0304	Hydraulic Hose - #6 x 276 "	1
6	B02-01-0305	Hydraulic Hose - #6 x 276 "	1
7	B02-01-0306	Hydraulic Hose - #6 x 22 "	1
8	B02-01-0307	Hydraulic Hose - #4 x 22 "	1
9	B02-01-0291	Hydraulic Hose - #4 x 15 "	1
10	B02-01-0308	Hydraulic Hose - #4 x 384 "	1
11	B02-01-0309	Hydraulic Hose - #4 x 384 "	1
12	B02-01-0235	Hydraulic Hose - #4 x 16 "	1
13	B02-01-0234	Hydraulic Hose - #4 x 16 "	1
14	B02-01-0294	Hydraulic Hose - #6 x 20 "	1
15	B02-01-0295	Hydraulic Hose - #4 x 20 "	1
16	B02-01-0310	Hydraulic Hose - #6 x 222 "	1
17	B02-01-0311	Hydraulic Hose - #4 x 222 "	1
18	B02-01-0298	Hydraulic Hose - #6 x 20 "	1
19	B02-01-0299	Hydraulic Hose - #4 x 20 "	1
20	B02-01-0312	Hydraulic Hose - #6 x 390 "	1
21	B02-01-0301	Hydraulic Hose - #6 x 60"	1
22	B02-01-0345	Hydraulic Hose - #4 x 390 "	1
23	B02-01-0343	Hydraulic Hose - #4 x 60 "	1
24	B02-01-0282	Hydraulic Hose - #2 x 20"	1
25	B02-01-0260	Hydraulic Hose - #6 x 20"	1

FITTINGS KIT (A-02269F)

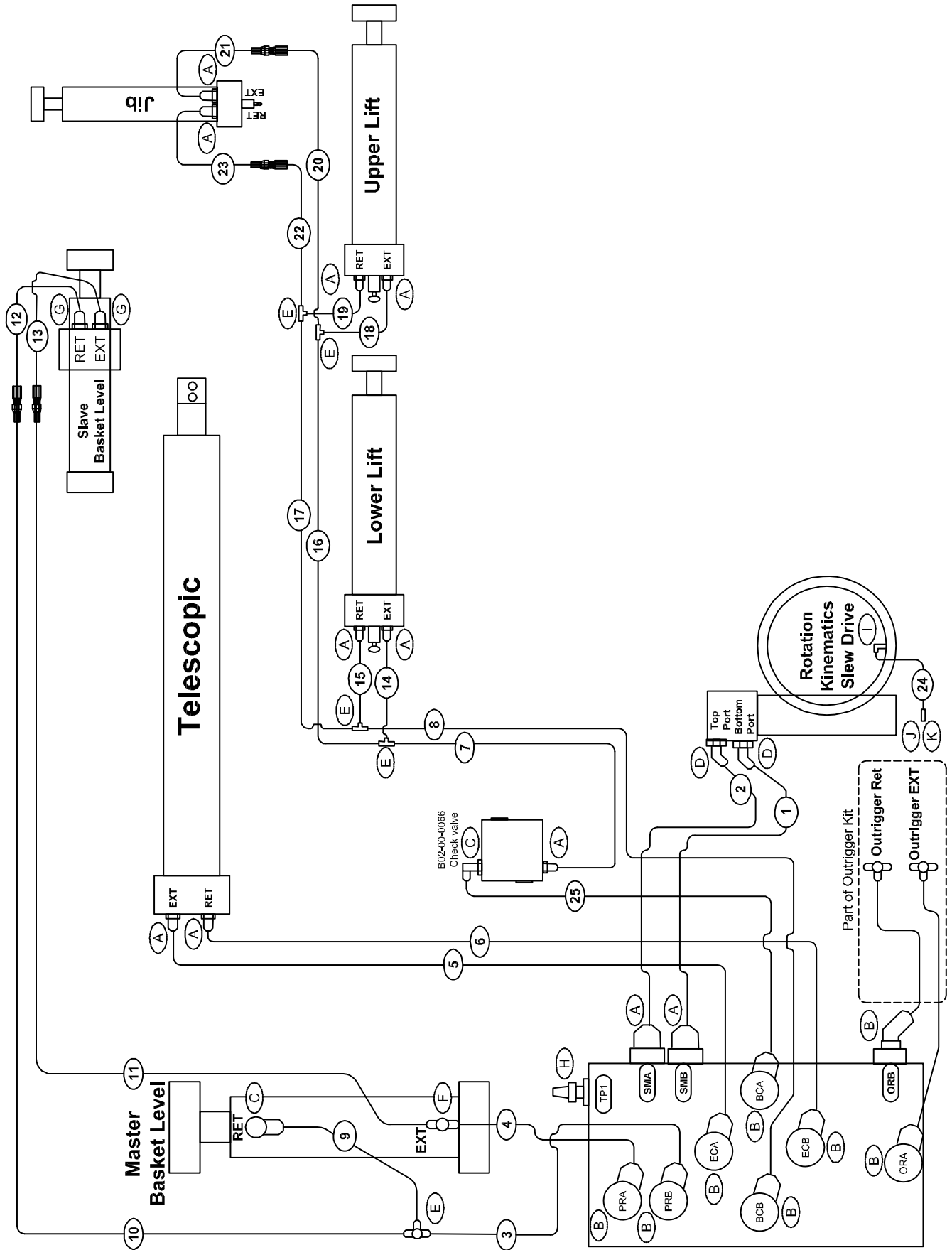

FITTINGS KIT (A-02269F) PARTS LIST

Item No.	Part No.	Description	Qty.
A	B02-02-0259	Fitting-#6MORFS-#6MORB STR	11
B	B02-02-0264	Fitting-#6MORFS-#6MORB 45	8
C	B02-02-0260	Fitting-#6MORFS-#6MORB 90	2
D	B02-02-0262	Fitting-#8MORFS-#10MORB 45	2
E	B02-02-0258	Fitting-#6MORFS Tee	5
F	B02-02-0270	Fitting-#6MORFS-#6MORB-#6MORB Tee	1
G	B02-02-0237	Fitting-#4MORFS-#6MORB STR	2
H	B02-02-0242	Fitting-#QD - #4MORB Diagnostic Nipple	1
I	B02-02-0317	Fitting-#2MNPT - #2FMNPT 90	1
J	B02-00-0081	Zerk-Grease-Bulk Head	1
K	B02-00-0082	Nut-Lock-#2 Bulk Head	1

KIT- HOSE – 55XA DRIVE (A-02075)

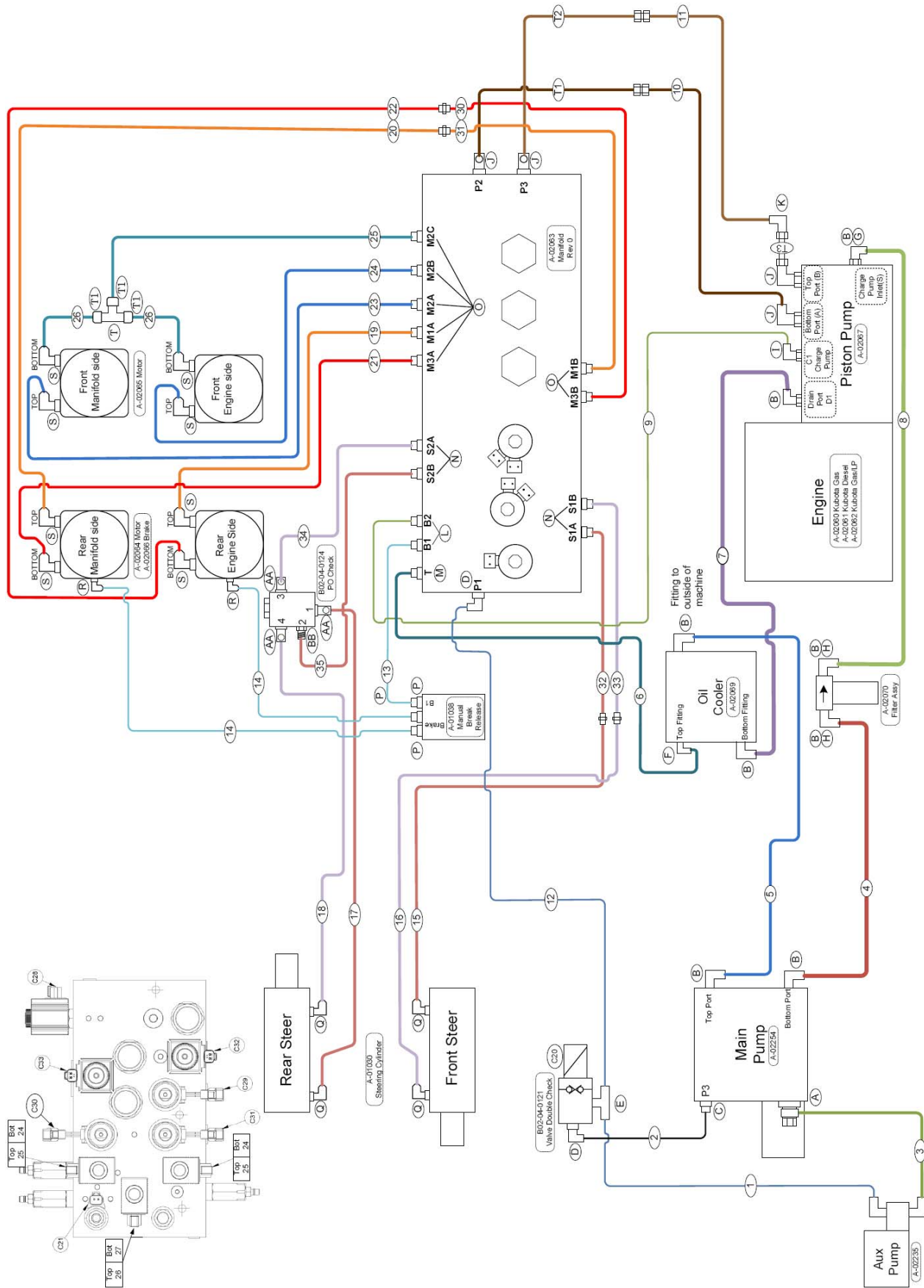

KIT- HOSE – 55XA DRIVE (A-02075) PARTS LIST

Item No.	Part No.	Size	Hose Type	length	Fitting end 1	Label end 1	Fitting end 2	Label end 2	Qty
1	B02-01-0425	6	A	44"	#6FMORFS STR	AUX PUMP	#6FMORFS 90	C 20 TEE	1
2	B02-01-0426	6	A	17"	#6FMORFS STR	P3	#6FMORFS STR	C 20	1
3	B02-01-0353	8	B	28"	#8 01 N-Metric Banjo Str	Tank	#8 FMORFS STR	Aux Pump T	1
4	B02-01-0427	10	A	104"	#10FMORFS STR	#4	#10FMORFS STR	#4	1
5	B02-01-0428	10	A	134"	#10FMORFS STR	#5	#10FMORFS STR	#5	1
6	B02-01-0429	8	A	52"	#8FMORFS STR	MANIFOLD T	#8FMORFS STR	COOLER T	1
7	B02-01-0430	10	A	48"	#10FMORFS STR	#7	#10FMORFS STR	#7	1
8	B02-01-0431	10	A	36"	#10FMORFS STR	#8	#10FMORFS STR	#8	1
9	B02-01-0432	4	A	28"	#4 FMORFS STR	#9 (B2)	#6 FMORFS STR	#9 (C1)	1
10 *	B02-01-0433	16	A	18.25"	#16MORFS STR	#10	#16FMORFS 90l	#10	1
11 *	B02-01-0434	16	A	17.125"	#16MORFS STR	#11	#16FMORFS STR	#11	1
12	B02-01-0435	6	A	94"	#6FMORFS STR	#12	#6FMORFS STR	#12	1
13	B02-01-0436	4	A	18"	#4FMORFS STR	#13	#4FMORFS STR	#13	1
14	B02-01-0437	4	A	108"	#4FMORFS STR	Brake(#14)	#4FMORFS STR	Brake(#14)	2
15	B02-01-0438	6	A	83"	#6FMORFS STR	Front Steer Bore End (#15)	#6FMORFS STR	S1A (#15)	1
16	B02-01-0439	6	A	93"	#6FMORFS STR	Front Steer Rod End (#16)	#6FMORFS STR	S1B (#16)	1
17	B02-01-0440	6	A	93"	#6FMORFS STR	Rear Steer Bore End (#17)	#6FMORFS STR	S2B (#17)	1
18	B02-01-0441	6	A	103"	#6FMORFS STR	Rear Steer Rod End (#18)	#6FMORFS STR	S2A (#18)	1
19	B02-01-0442	10	A	95"	#10FMORFS STR	REAR ENGINE SIDE TOP	#10FMORFS STR	#19 (M1A)	1
20	B02-01-0443	10	A	95"	#10FMORFS STR	REAR MANIFOLD SIDE TOP	#10FMORFS STR	#20 (M1B)	1
21	B02-01-0444	10	A	95"	#10FMORFS STR	REAR MANIFOLD SIDE BOTT	#10FMORFS STR	#21 (M3A)	1
22	B02-01-0445	10	A	95"	#10FMORFS STR	REAR ENGINE SIDE BOTT	#10FMORFS STR	#22 (M3B)	1
23	B02-01-0446	10	A	111"	#10FMORFS STR	FRONT MANIFOLD SIDE TOP	#10FMORFS STR	#23 (M2A)	1
24	B02-01-0447	10	A	111"	#10FMORFS STR	FRONT ENGINE SIDE TOP	#10FMORFS STR	#24 (M2B)	1
25**	B02-01-0448	10	A	63"	#10MUPTC STR	TEE	#10FMORFS STR	#25 (M2C)	1
26**	B02-01-0449	10	A	45"	#10MUPTC STR	#26 (TEE)	#10FMORFS STR	FRONT BOTT	2

KIT- FITTING – 55X DRIVE (A-02075F) PARTS LIST

Item	Part No.	Description	Qty
A	B02-02-0318	#12MSAE-ORB-FM M18 x 1.5	1
B	B02-02-0329	10MORFS-12MSAE-ORB 90	8
C	B02-02-0259	6MORFS-6MSAE-ORB STR	1
D	B02-02-0260	6MORFS-6MSAE-ORB 90	2
E	B02-02-0270	6MORFS-6MORFS-6MSAE-ORB TEE	1
F	B02-02-0312	8MORFS-8MSAE-ORB 90	1
G	B02-02-0319	16MSAE-ORB-12FMSAE-ORB STR	1
H	B02-02-0320	20MSAE-ORB-12FMSAE-ORB STR	2
I	B02-02-0321	6MORFS-8MSAE-ORB 90	1
J	B02-02-0322	16MORFS-16MSAE-ORB 90	4
K	B02-02-0323	#16MORFS-#16MORFS 90	1
L	B02-02-0237	4MORFS-6MSAE-ORB STR	2
M	B02-02-0293	8MORFS-8MSAE-ORB STR	1
N	B02-02-0265	6MORFS-8MSAE-ORB STR	4
O	B02-02-0324	10MORFS-10MSAE-ORB STR	7
P	B02-02-0287	4MORFS-4MSAE-ORB STR	3
Q	B02-02-0325	6MORFS-4MSAE-ORB 90	4
R	B02-02-0288	4MORFS-4MSAE-ORB 90	2
S	B02-02-0326	10MORFS-10MSAE-ORB 90 L (Long)	8
T	B02-02-0327	10MORFS-10MORFS-10MORFS TEE	1
T1	B02-02-0328	#10 UPTC Nut(Universal Push to Connect)	3

OUTRIGGER HYDRAULIC LINES (A-02077)

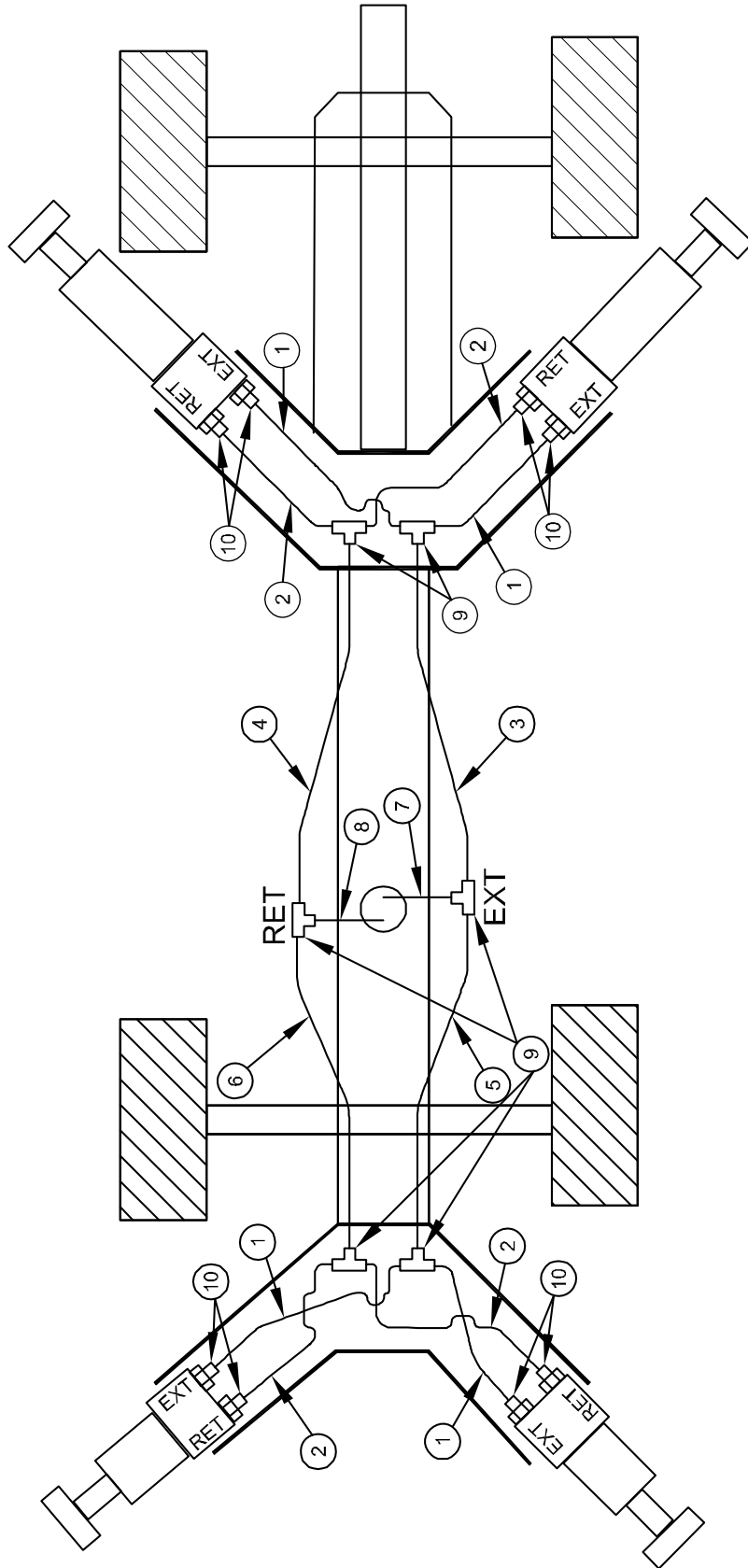

OUTRIGGER HYDRAULIC LINES (A-02077)

Item No.	Part No	Hose Type	Hose Size	Fitting End 1	End 1 Size	Fitting End 2	End 2 Size	Length	Hose Label End 1	Hose Label End 2	Tape Color End 1	Tape Color End 2	Qty
1	B02-01-0331	SAE 100R 17	4	#6FMORFS	6	#6FMORFS	6	40"	EXT	EXT	RED	RED	4
2	B02-01-0332	SAE 100R 17	4	#6FMORFS	6	#6FMORFS	6	40"	RET	RET	BLUE	BLUE	4
3	B02-01-0450	SAE 100R 17	6	#6FMORFS	6	#6FMORFS	6	67"	EXT	EXT	RED	RED	1
4	B02-01-0451	SAE 100R 17	6	#6FMORFS	6	#6FMORFS	6	67"	RET	RET	BLUE	BLUE	1
5	B02-01-0335	SAE 100R 17	6	#6FMORFS	6	#6FMORFS	6	31"	EXT	EXT	RED	RED	1
6	B02-01-0336	SAE 100R 17	6	#6FMORFS	6	#6FMORFS	6	31"	RET	RET	BLUE	BLUE	1
7	B02-01-0337	SAE 100R 17	6	#6FMORFS	6	#6FMORFS	6	54"	EXT	EXT	RED	RED	1
8	B02-01-0338	SAE 100R 17	6	#6FMORFS	6	#6FMORFS	6	54"	RET	RET	BLUE	BLUE	1

FITTING KIT

Item No.	Part No	Description	Qty
9	B02-02-0258	#6 MORFS-#6 MORFS-#6 MORFS TEE	6
10	B02-02-0259	#6 MORFS-#6 MORB STR	8

HARNESS-MANIFOLD-55XA (A-02732)

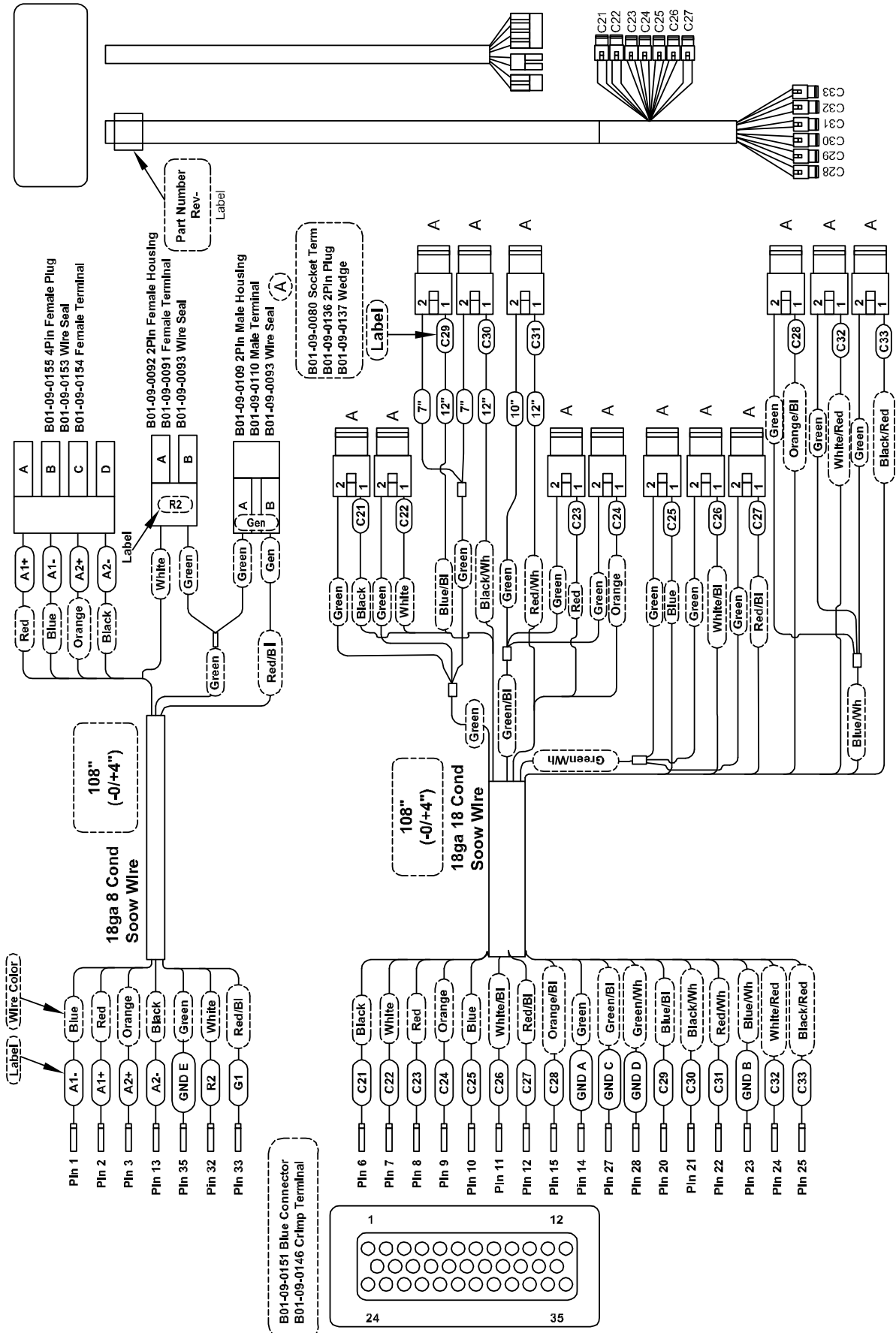

WIRE ASSEMBLY-R2 RELAY (A-02734)

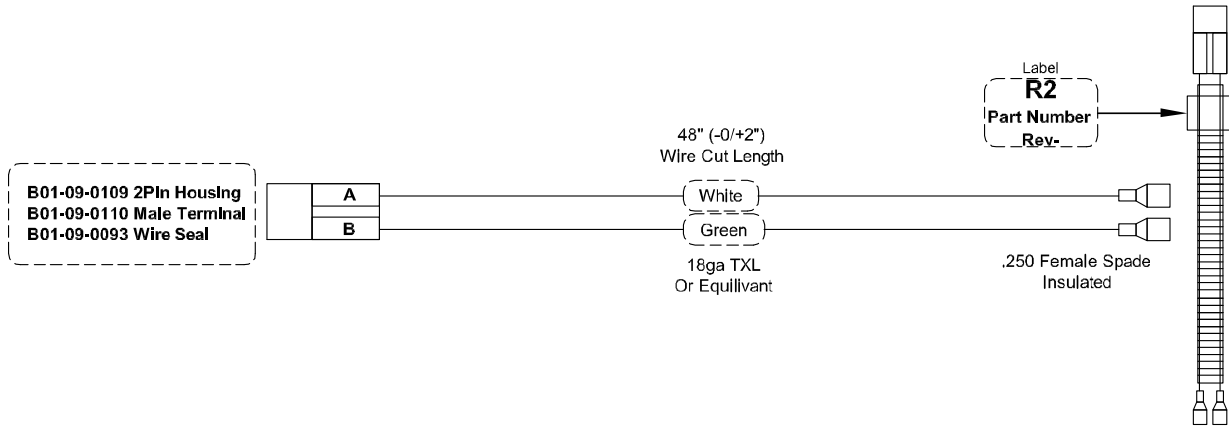

KIT-BATTERY CABLE 55XA (A-02273)

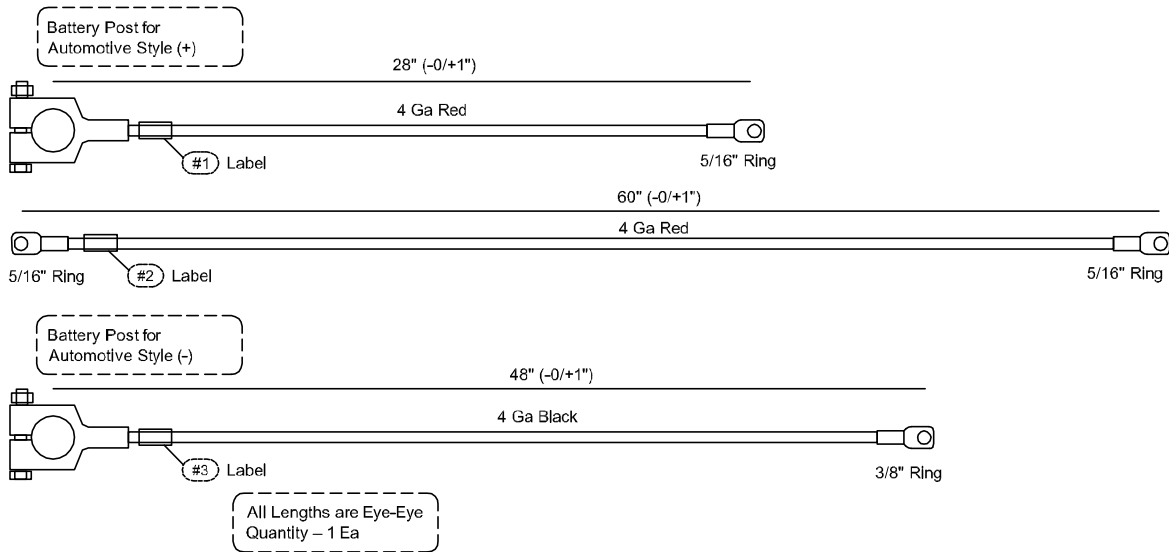

WIRE ASSEMBLY-C20 VALVE (A-02048)

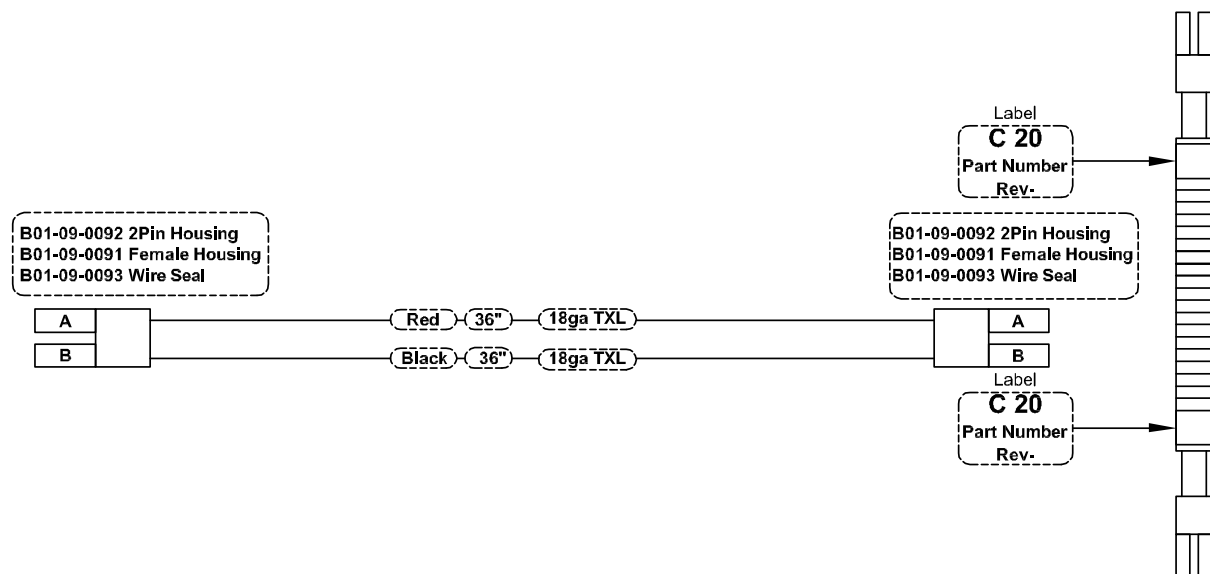

KIT-TUBE 55XA DRIVE (A-02076)

Part No.	Description	Qty
A-02076-T1	Tube Assembly	1
A-02076-T2	Tube Assembly	1
A-02076-T3	Tube Assembly	1
B04-07-0143	Clamp-Tube for 1" OD Steel Tube	4
B04-07-0144	Cover Plate for Tube Clamp	1

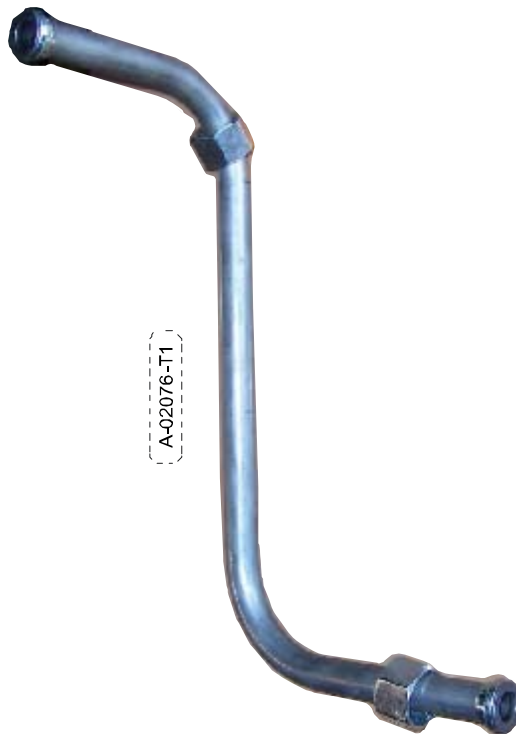

A-02076-T1

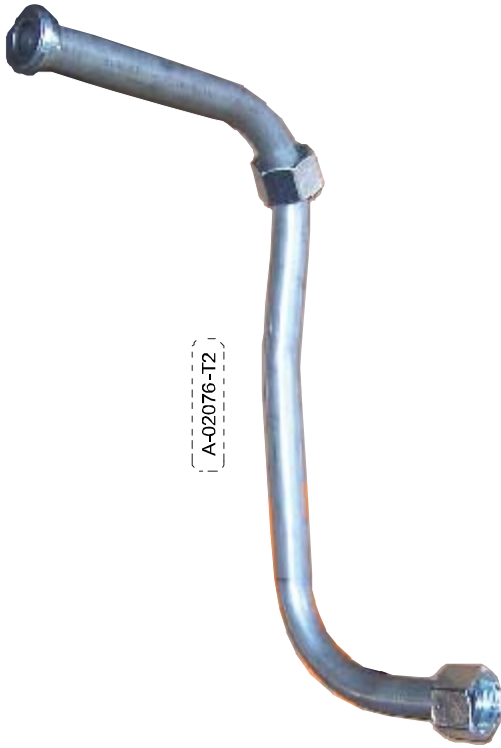

A-02076-T2

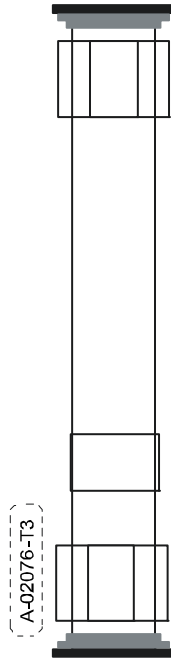

A-02076-T3

B04-07-0143 Tube Clamp Pieces

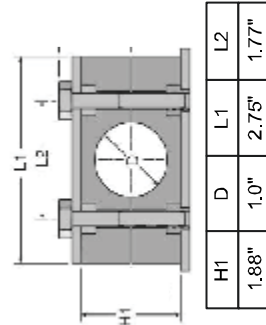

Material: Polypropylene
Color: Black
Designed to clamp 1" Steel Tubing

Dimensions are when 2 pieces are put together

B04-07-0144

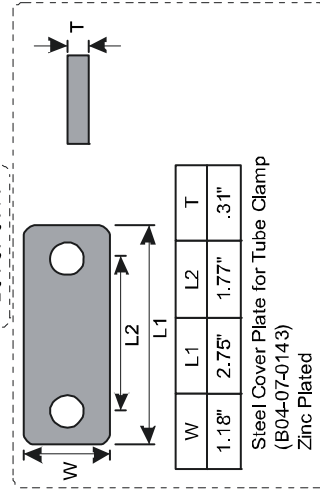

Steel Cover Plate for Tube Clamp
(B04-07-0143)
Zinc Plated

OUTRIGGER COIL WIRE HARNESS (A-02735)

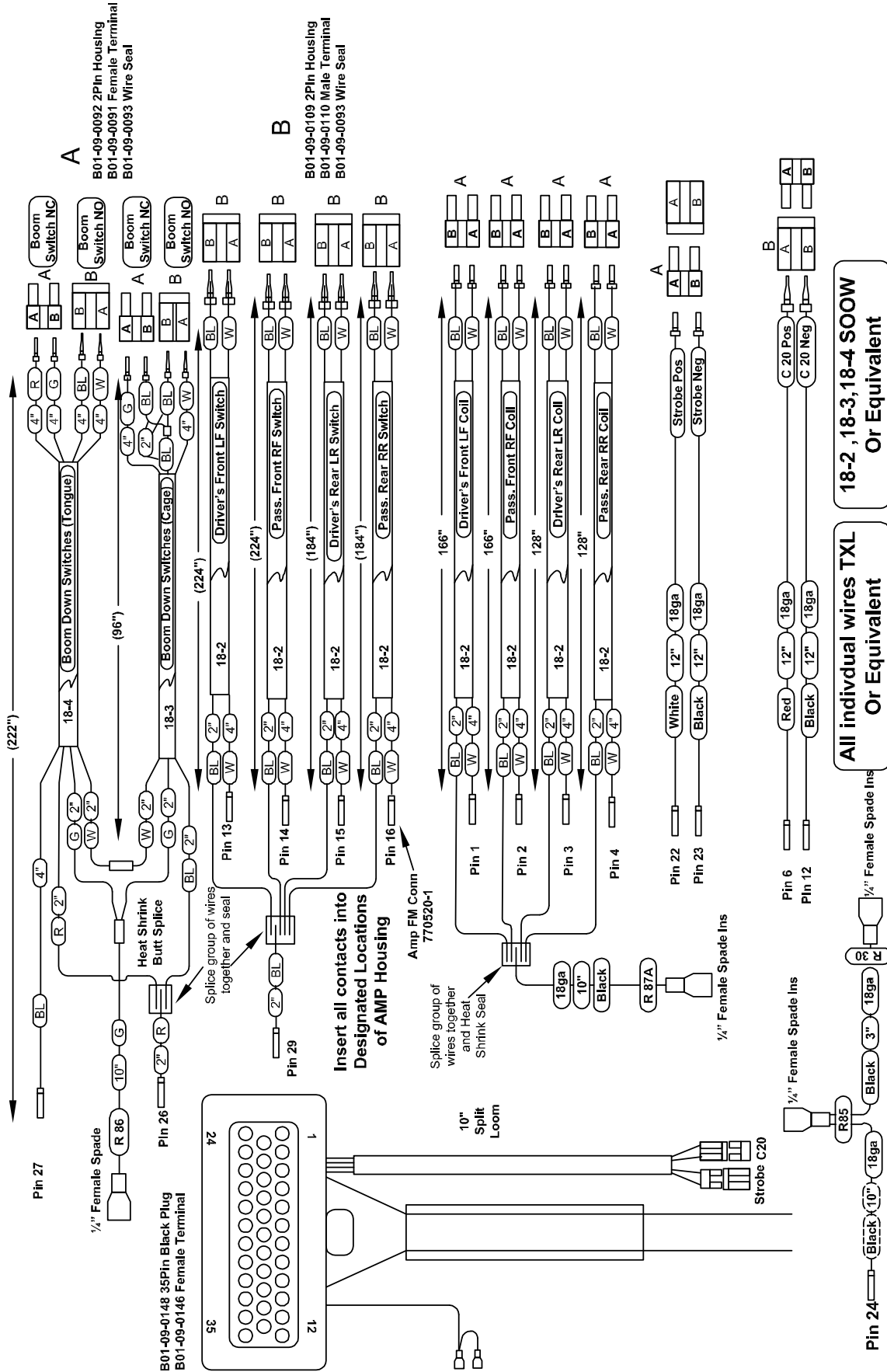

PLATFORM WIRE HARNESS (A-02714)

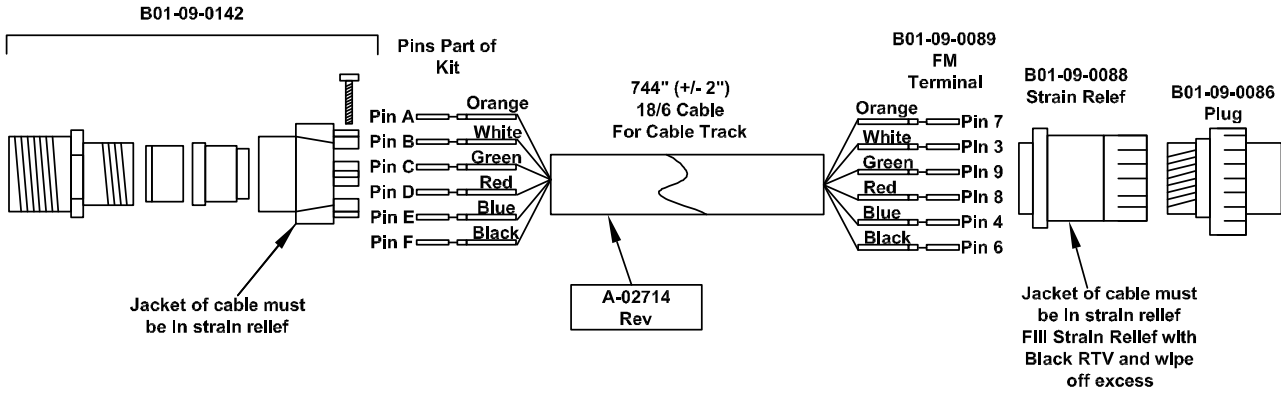

HARNESS-UPPER CONTROL BOX (B01-01-0154)

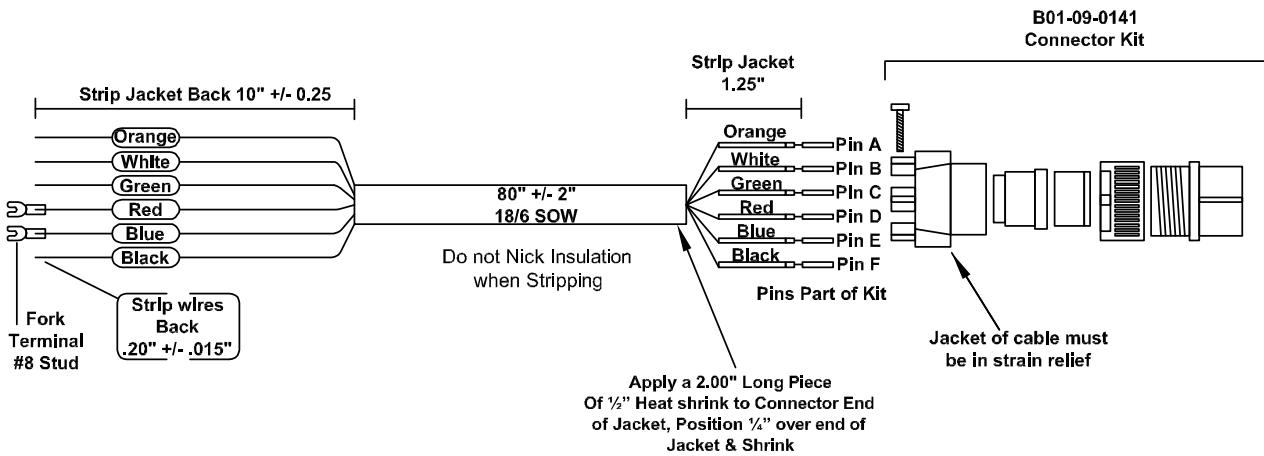

POWER HARNESS (A-02718)

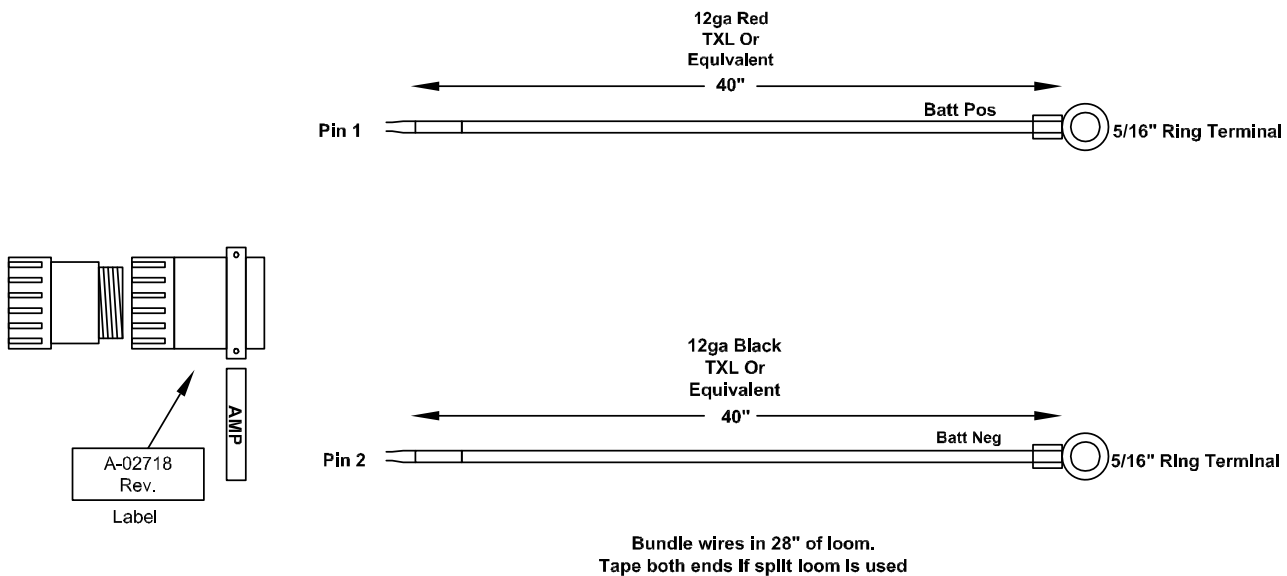

110VAC TOWER-PLATFORM HARNESS (A-02722)

B01-09-0123 3Pin Housing
 B01-09-0110 Male Terminal
 B01-09-0119 Wire Seal

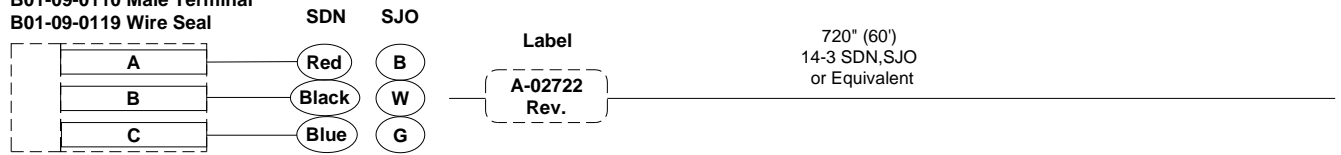

SECONDARY CYLINDER WIRE (A-02724)

B01-09-0092 Pin Housing
 B01-09-0091 Female Terminal
 B01-09-0093 Wire Seal

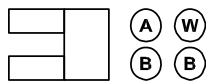

Sec Cyl Wire

23'6"
 18-2 SJO or Equivalent

Label Both ends

Sec Cyl Wire

B01-09-0109 Pin Housing
 B01-09-0110 Male Terminal
 B01-09-0093 Wire Seal

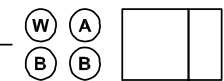

JIB WIRE (A-02725)

B01-09-0092 Pin Housing
 B01-09-0091 Female Terminal
 B01-09-0093 Wire Seal

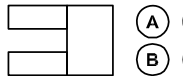

Label
 Part Number
 Rev-

7'26" (+/-2")
 18-2 SJO or Equivalent

Label
 Part Number
 Rev-

B01-09-0109 Pin Housing
 B01-09-0110 Male Terminal
 B01-09-0093 Wire Seal

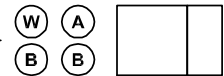

WIRING ASSEMBLY-FAN-COOLER-55XA (A-02041)

B01-09-0092 Pin Housing
 B01-09-0091 Female Terminal
 B01-09-0093 Wire Seal

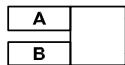

Black
 Blue

B01-09-0109 Pin Housing
 B01-09-0110 Female Terminal
 B01-09-0093 Wire Seal

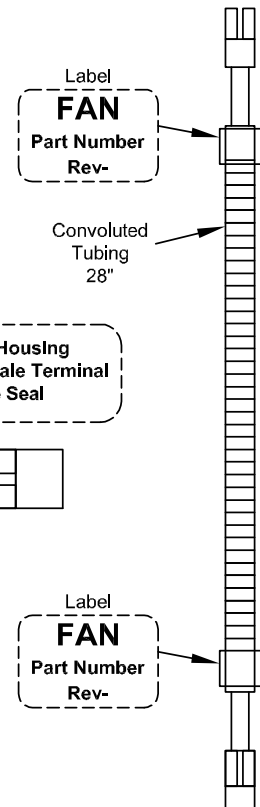
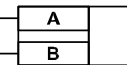

BATTERY CABLE LAYOUT

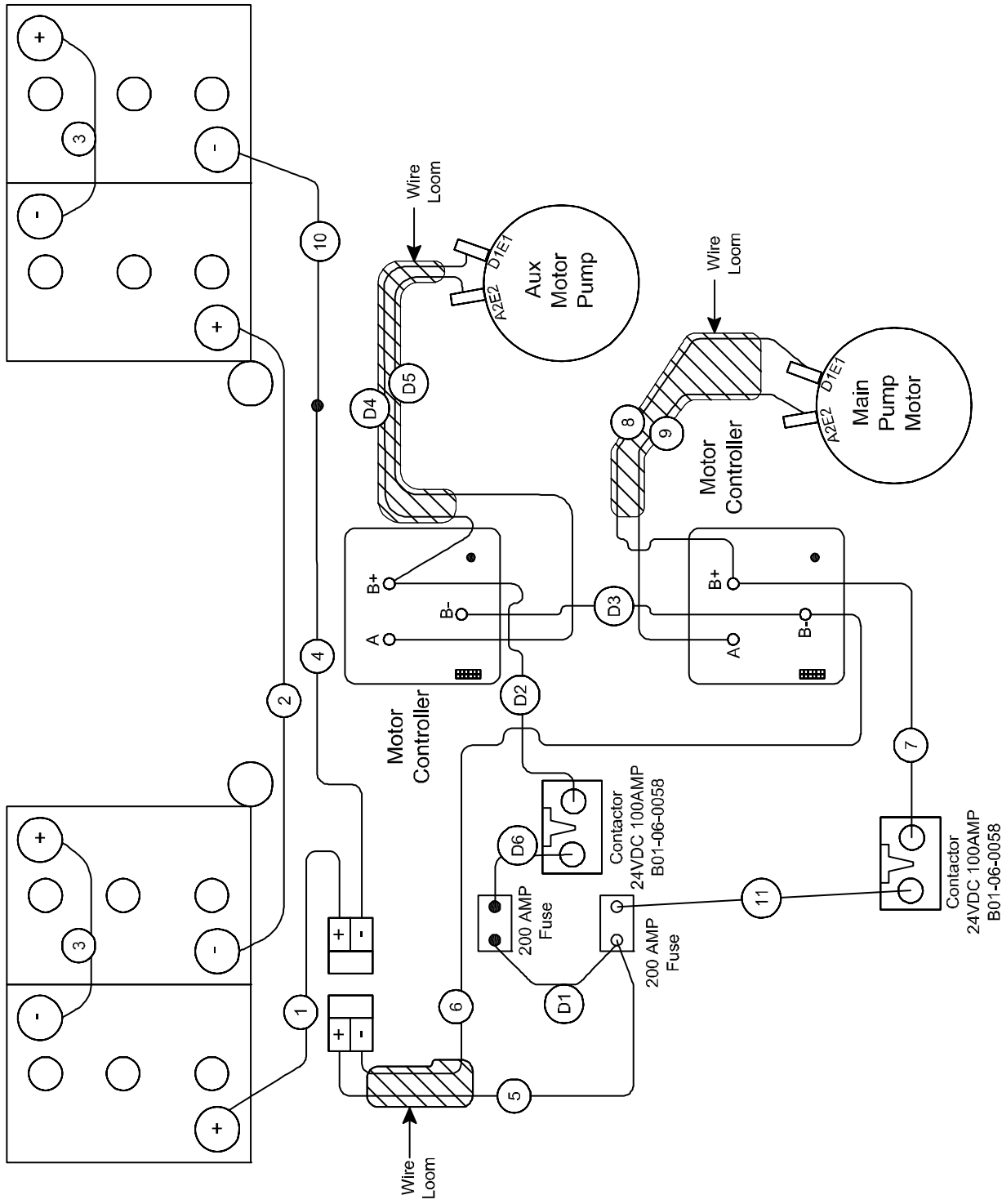

BATTERY CABLE LAYOUT (KIT A-02272)

Item No.	Gauge	Color	Length	End	Label	End	Qty
1	2ga	Red	32"	5/16 Lug	#1	SBC	1
2	2ga	Black	45"	5/16 Lug	#2	5/16 Lug	1
3	2ga	Black	8"	5/16 Lug	#3	SBC	2
4	2ga	Black	20"	5/16 Lug	#4	SBC	1
5	2ga	Red	28"	5/16 Lug	#5	SBC	1
6	2ga	Black	60"	5/16 Lug	#6	5/16 Lug	1
7	2ga	Red	30"	5/16 Lug	#7	5/16 Lug	1
8	2ga	Red	48"	5/16 Lug	#8	5/16 Lug	1
9	2ga	Black	45"	5/16 Lug	#9	5/16 Lug	1
10	2ga	Black	20"	5/16 Lug	#10	5/16 Lug	1
11	2ga	Red	13"	5/16 Lug	#11	5/16 Lug	1

Description	Qty
Terminal Protector (Black)	5
Terminal Protector (Red)	7
SBC Housing (Red) 175 amp	2
A-Frame Handle	1

SECONDARY PUMP AND MOTOR CONTROL (KIT A-00943)

Item No.	Ga	Length	Color	Terminal	Terminal	Qty
D1	2ga	6"	Red	5/16 Lug	5/16 Lug	1
D2	2ga	30"	Red	5/16 Lug	5/16 Lug	1
D3	2ga	13"	Black	5/16 Lug	5/16 Lug	1
D4	2ga	40"	Red	5/16 Lug	5/16 Lug	1
D5	2ga	40"	Black	5/16 Lug	5/16 Lug	1
D6	2ga	20"	Red	5/16 Lug	5/16 Lug	1

7 EQUIPMENT OPTIONS

The Haulotte Group | BilJax Model 55XA may be equipped with one or more optional components designed for the convenience and safety of operators when using the equipment to accomplish specific tasks.

Always use only those components manufactured and/or authorized by Haulotte Group | BilJax. Never make any adjustments or modifications or otherwise alter the equipment in any way that is not expressly recommended by the manufacturer.

When operating a machine equipped with optional components, observe all safety precautions set forth by the manufacturer, as well as all government codes and regulations regarding this equipment and its components.

Consult rental agency or equipment manufacturer regarding which optional components may be installed on the boom lift. For questions regarding safe use, contact your regional Haulotte Group | BilJax dealer before attempting operation.

Assembly Description	Page
MATERIAL LIFT ASSEMBLY (OPTION A-01846)	132
MATERIAL LIFT ASSEMBLY PART LIST	133
MATERIAL LIFTING HOOK INSTALLATION PROCEDURE	136
LOAD CELL CALIBRATION PROCEDURE	138
MANUAL PLATFORM ROTATOR ASSEMBLY (OPTION A-00300)	140
MANUAL PLATFORM ROTATOR ASSEMBLY PARTS LIST	141
PLATFORM ROTATOR INSTRUCTIONS	142
WATER LINE TO PLATFORM (OPTION A-02701)	143
AIR LINE TO PLATFORM (OPTION A-02700).....	143
HARNESMANUAL OUTRIGGER CONTROL (A-00819) OPTION	144
HYDRAULIC PRESSURE GAUGE (B02-16-0020) OPTION	145

MATERIAL LIFT ASSEMBLY (OPTION A-01846)

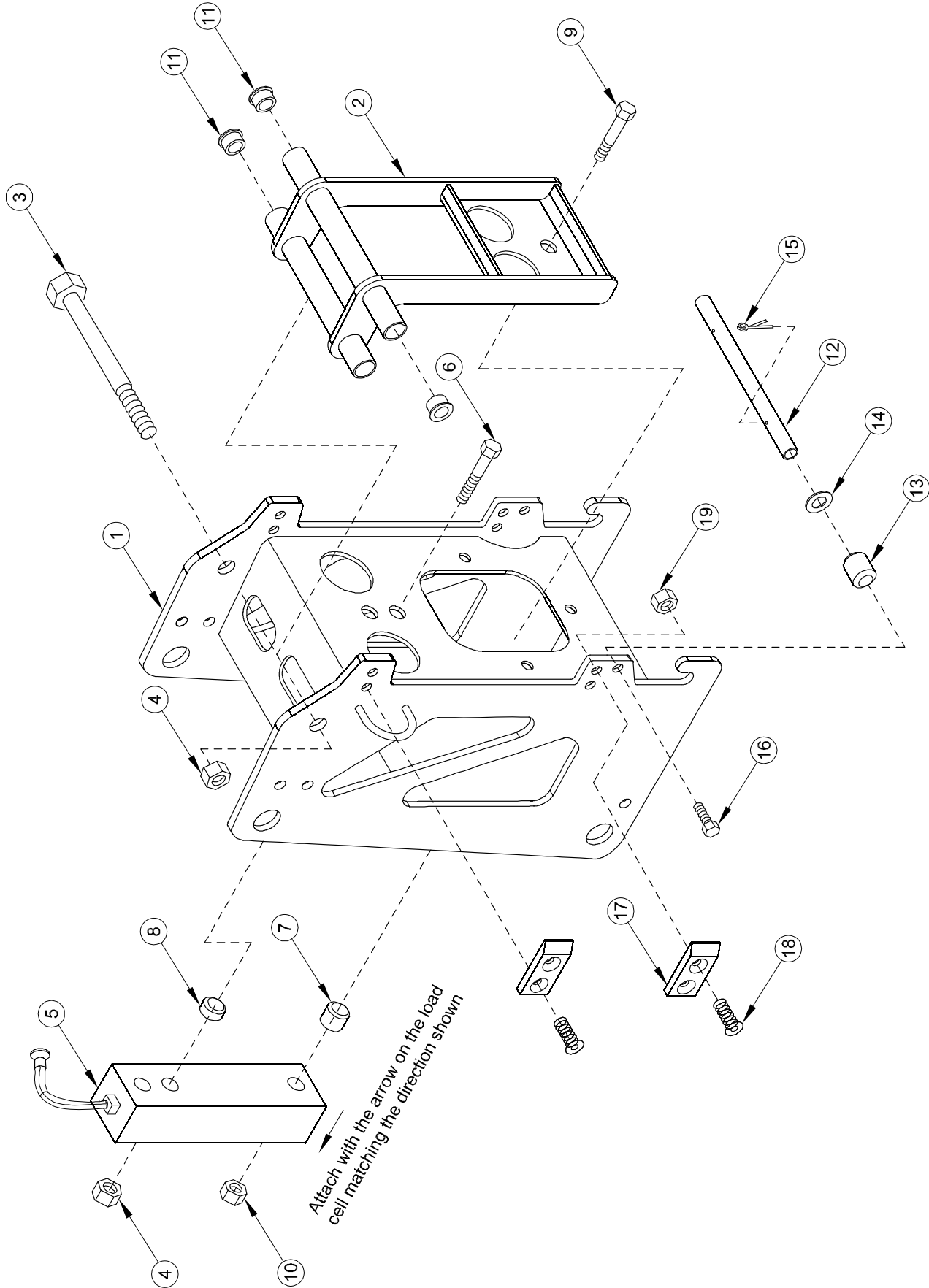

MATERIAL LIFT ASSEMBLY PARTS LIST

Item No.	Part No.	Description	Qty.
1	A-01977	Jib End Weldment - LS	1
2	A-00982	Load Sense Weldment	1
3	0096-0055	Cap Screw-M12x190	1
4	0096-0042	Hex Nut-Self-Locking M12	3
5	A-00988-1	Load Cell	1
6	0096-0089	Cap Screw-M12x65	2
7	A-00990A	Load Sense Spacer A	2
8	A-00990B	Load Sense Spacer B	1
9	0096-0069	Cap Screw-M10x75	1
10	0096-0041	Hex Nut-Self-Locking M10	1
11	A-00033	Bearing	4
12	A-00994	LS Roller Bar	1
13	A-00995	LS Roller	2
14	0096-0046	Washer-Flat-M12	10
15	0090-0147	Cotter Pin	2
16	0096-0009	Cap Screw-M8x10	2
17	A-00038	Ramp	4
18	0096-0003	Screw-FHCS-M6x20	8
19	0096-0039	Hex Nut-Self-Locking M6	8
20	A-00992	Load Sense Interface (Not Pictured)	1
21	0096-0085	Cap Screw-M6x60	3
22	0096-0039	Hex Nut- Self-Locking -M6	3

MATERIAL LIFT ASSEMBLY

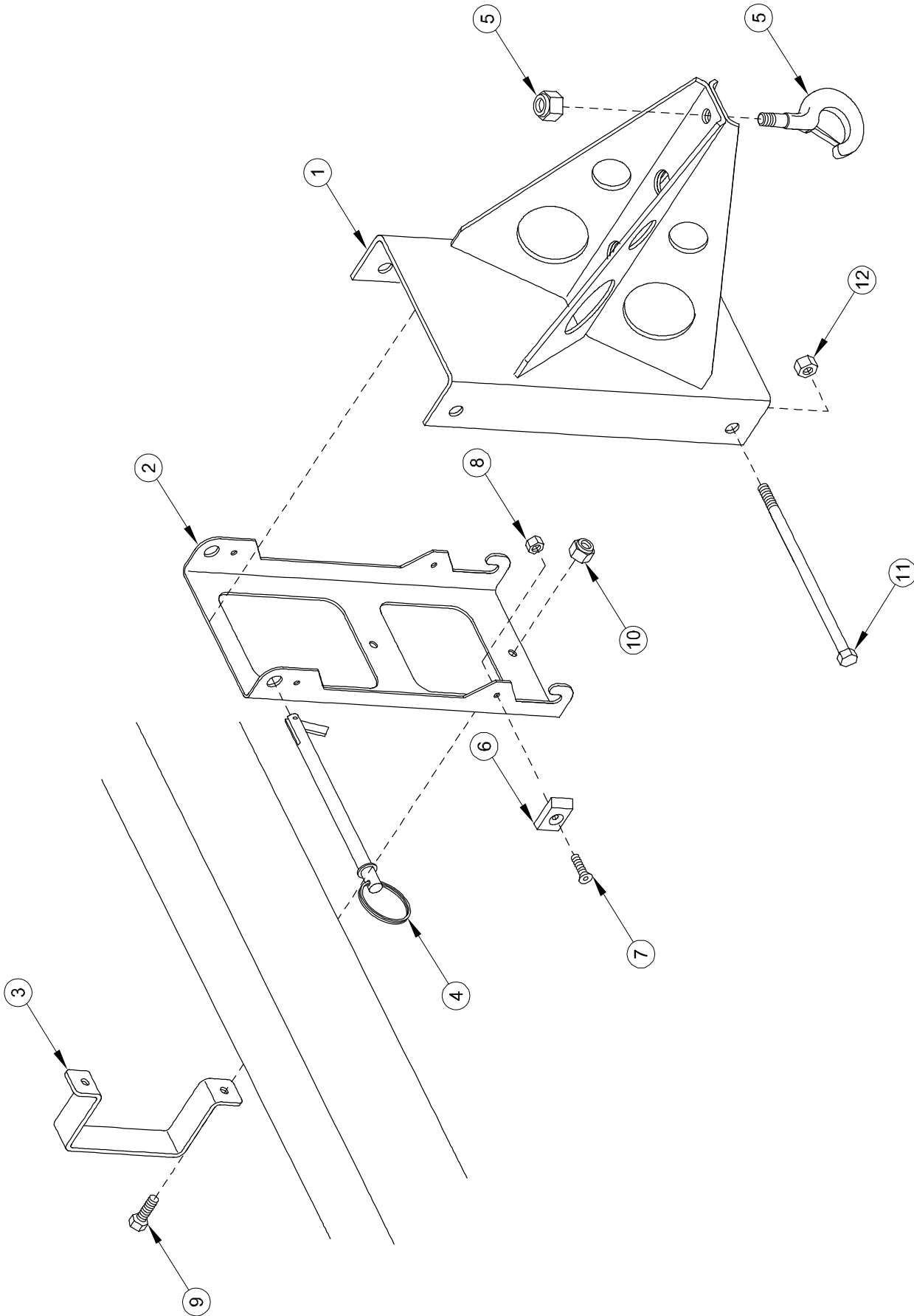

MATERIAL LIFT ASSEMBLY PARTS LIST

Item No.	Part No.	Description	Qty.
1	A-00480	Material Lift Weldment	1
2	A-00155	Lift Hook Storage Bracket	1
3	A-01156	Bracket Clamp	1
4	A-00028	Pin	1
5	A-00485	Lift Hook Assembly	1
6	A-00037	Ramp, Short	4
7	0096-0003	FHCS-M6x20	4
8	0096-0039	Hex Nut- Self-Locking M6	4
9	0096-0016	Cap Screw- M10x25	2
10	0096-0041	Hex Nut-Self-Locking -M10	2
11	0096-0029	Cap Screw-M12x220	1
12	0096-0042	Hex Nut- Self-Locking -M12	1

MATERIAL LIFTING HOOK INSTALLATION PROCEDURE

If the boom lift is equipped with a material lifting hook, observe the following procedure for material lift operation:

- Remove platform controls from the work platform by releasing the latch on the back of the platform control box
- Disconnect platform control box from the load sense module located on the boom lift bulkhead
- Remove the electric loopback plug from the receptacle on the bottom right of the ground control panel (Figure 7-1) and insert the platform control cable into the open receptacle

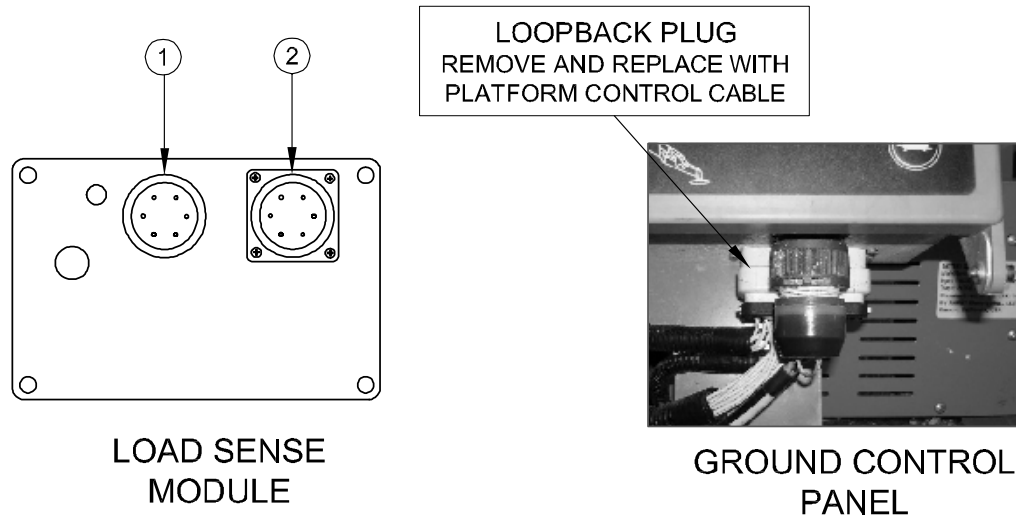

Figure 7-1 Material Lifting Hook Configuration

1. To Boom Cable.

- a. Do Not Remove.

2. To Platform Controls.

- a. Disconnect platform controls.
 - b. Replace with loopback plug from ground controls.
 - c. Plug platform controls into open receptacle on the bottom right of ground control panel.
- Insert the removed electric loopback plug into the open receptacle on the load sense module, replacing the platform control cable
 - Remove the retaining pin holding the platform to boom lift. Firmly secure platform to prevent equipment damage
 - Remove the platform from the boom by lifting cage up and away from the mounting bracket on the boom nose.
 - Attach the material lifting hook to the mounting bracket on the boom nose and insert the retaining pin (Figure 7-2)

MATERIAL LIFTING HOOK INSTALLATION PROCEDURE (Continued)

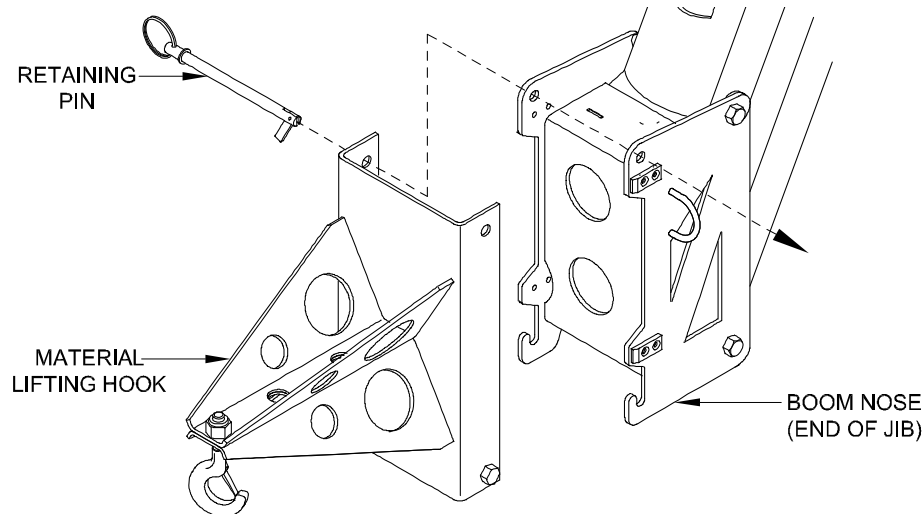

Figure 7-2 Material Lifting Hook Installation

- Operate the material lifting hook remotely, using the platform control box for optimal control

⚠ WARNING

Always observe the manufacturer's weight lifting limitations when using the material lifting hook. Always use lifting straps or wire rope slings that are rated at a minimum 500 lbs lifting capacity. Never stand beneath an elevated load or position an elevated load above personnel. Falling objects can cause serious injury or death.

⚡ DANGER

This machine is not insulated for use near electrical power lines and DOES NOT provide protection from contact with or close proximity to any electrically charged conductor. Operator must maintain safe clearances at all times and always allow for platform movement such as wind-induced sway. Refer to Table 1-1 for minimum safe approach distances between the machine and electrical power lines.

- Reverse the procedure to reattach the work platform

LOAD CELL CALIBRATION PROCEDURE

- (1) Remove quick pull pin securing the basket to the platform mount bracket.
- (2) Enter the maintenance mode by pressing both rotate keys and the outrigger extend key on lower control panel simultaneously and holding for 5 seconds.
- (3) Scroll through the maintenance menu using the turtle key until "Load Sense Zero Calibration Utility" is found.
- (4) Press both mid speed keys on lower control panel simultaneously. Three consecutive beeps will sound and the display will read "Load Sense Has Been Zero Calibrated" confirming the operation. The maintenance mode will then go to "Load Sense Scaling Utility".
- (5) In "Load Sense Scaling Utility", the display should read a ratio of "3.68:1=0". If ratio is not "3.68:1", continue to step 6. If ratio is correct, but load is not "=0", skip to step 7. If both ratio and load are correct, skip to step 8.
- (6) If the ratio is not "3.68:1", press the mid-high or mid-low speed key until the ratio is correct. Continue to step 7.
- (7) Press the rabbit key to return to "Load Sense Zero Calibration Utility" and repeat steps 4 and 5. Display should read "3.68:1=0". If so, continue to step 8.
- (8) Exit maintenance by scrolling through the menu using the turtle key. Display should read "Boom Load=0000 lbs/kg".
- (9) Return basket to upright position and install upper mounting pin (quick pull pin). Display should read 65lbs/30kg (+/-10%).

Note: Display should read 125lbs/57kg for lifts with Platform Rotate.

- (10) Add between 350-400lbs/159-182kg to basket.

Note: Be sure know accurately (within + or -5lbs/2.3kg) how much weight is going into the basket.

- (11) The "Boom Load" on the display should read the added weight plus the initially displayed weight (+/-10%).

$$\text{Minimum Load} = 0.9(W1 + W2)$$

$$\text{Maximum Load} = 1.1(W1 + W2)$$

Where W1=Initial displayed weight and W2=Added weight.

- (12) If displayed load is within tolerances, skip to step 14. If not, return to maintenance mode and scroll **PAST** "Load Sense Zero Calibration Utility" directly to "Load Sense Scaling Utility".
- (13) Adjust displayed weight by pressing mid-high or mid-low speed until weight is within tolerances, then exit maintenance mode. Ratio should be within **3.50:1** to **4.00:1**. If so, continue with step 14. If ratio is not within above values, contact Bil-Jax Service.
- (14) Remove weight from basket. Boom Load should return to initially displayed weight as in step 9.
- (15) Return weight to the basket. Boom Load should read as observed in step 11.
- (16) Repeat steps 14 and 15, then remove weight and turn off machine.
- (17) Turn machine back on and display should read as in step 9.
- (18) Repeat steps 14 and 15 twice making sure that Boom Load is reading properly.
- (19) Operate all functions in all speeds from both upper and lower controls to verify proper operation.
- (20) Recalibration is complete.

MANUAL PLATFORM ROTATOR ASSEMBLY (OPTION A-00300)

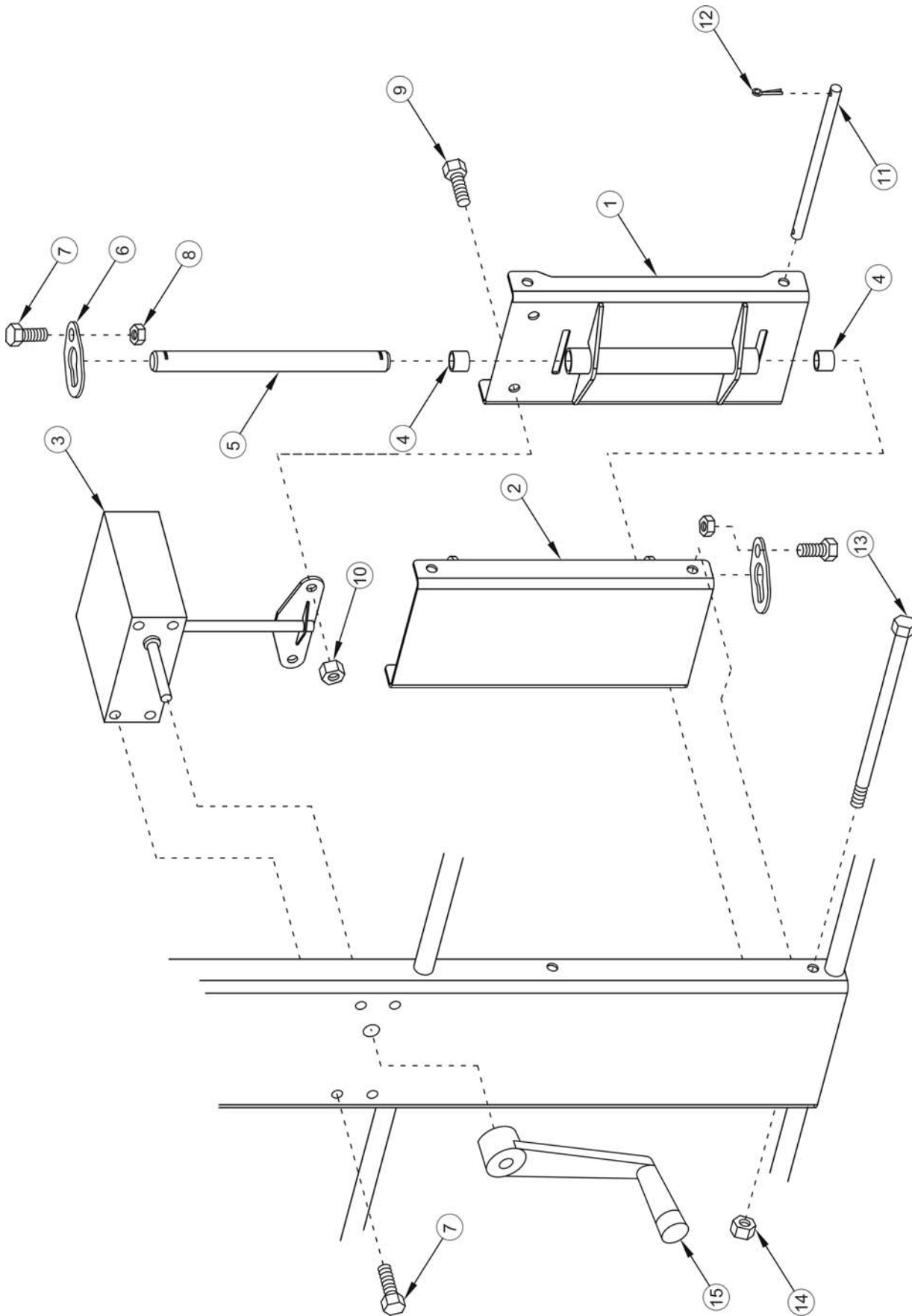

MANUAL PLATFORM ROTATOR ASSEMBLY PARTS LIST

Item No.	Part No.	Description	Qty.
1	A-00301	Platform Mount A Weldment	1
2	A-00308	Platform Mount Weldment	1
3	A-00315	Gearbox – Platform Rotate	1
4	A-00330	Bearing – .75" ID	2
5	A-00329	Pin – 0.75 x 10.25 DB	1
6	A-00017	Pin Retainer – 0.75	2
7	0096-0014	Cap Screw-M10x20	6
8	0096-0041	Hex Nut-Self-Locking -M10	2
9	0096-0019	Cap Screw-M12x25	2
10	0096-0042	Hex Nut-Self-Locking-M12	2
11	A-00071	Pin-Platform	1
12	0090-0147	Cotter Pin	2
13	0096-0103	Cap Screw-M8x140	2
14	0096-0040	Hex Nut-Self-Locking -M8	2
15	A-00325	Handle Assembly – Platform Rotate	1

PLATFORM ROTATOR INSTRUCTIONS

The optional platform rotator allows the operator to rotate the elevated work platform 90° around a vertical axis by actuating a rotator handle found below the platform control panel.

To operate manual platform rotator, turn the rotator handle in the direction of desired rotation (clockwise or counterclockwise). Motion continues in the desired direction until rotator handle is released or the platform reaches a safe travel limit.

WARNING

Installation of a manual platform rotator will reduce the rated load limit of the work platform to 440 lbs. (200 kg). Follow all manufacturer's recommendations and safety precautions when operating a boom lift equipped for platform rotation.

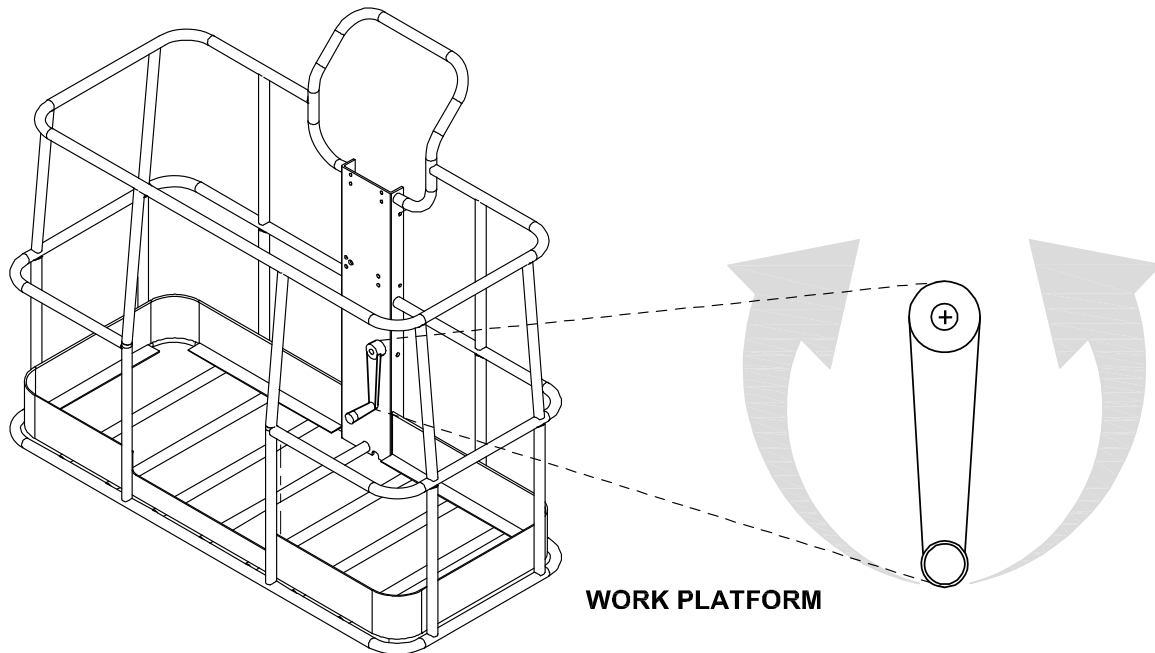

Figure 7-3 Manual Platform Rotator

WATER LINE TO PLATFORM (OPTION A-02701)

Part No.	Description
B09-00-0042	#6 x 146" W/1-6-6FMP, 1-6-6MP 3000 PSI Pressure Washer Hose
B09-00-0043	#6 x 628" W/2-6-6MPSW 3000 PSI Pressure Washer Hose
B09-00-0041	#6 x 78" W/1-6-6FMP, 1-6-6MP 3000 PSI Pressure Washer Hose
B09-00-0032	Fitting, QD E Series FM-#6FMNPT
B09-00-0033	Fitting, QD E Series M-#6FMNPT

AIR LINE TO PLATFORM (OPTION A-02700)

Part No.	Description
B09-00-0037	#6 x 146" W/1-6-6FMPSW, 1-6-6MP 300 PSI Air Hose
B09-00-0038	#6 x 628" W/2-6-6MP 300 PSI Air Hose
B09-00-0036	#6 x 78" W/1-6-6FMPSW, 1-6-6MP 300 PSI Air Hose
B02-02-0108	Fitting, #6FMNPT-#4FMNPT STR
B09-00-0025	Fitting, Univ QD FM-#4MNPT
B09-00-0026	Fitting, QD IND Series M-#4MNPT
B09-00-0027	Fitting, QD ARO Series M-#4MNPT
B09-00-0028	Fitting, Univ QD FM-#6FMNPT
B09-00-0029	Fitting, QD DF Series M-#6FMNPT
B09-00-0030	Fitting, QD J Series M-#6FMNPT

HARNESS-MANUAL OUTRIGGER CONTROL (A-00819) OPTION

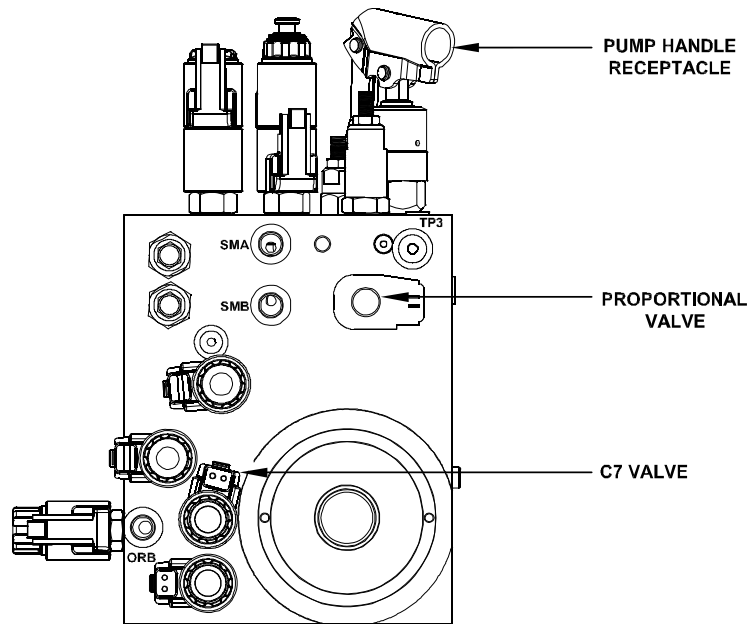
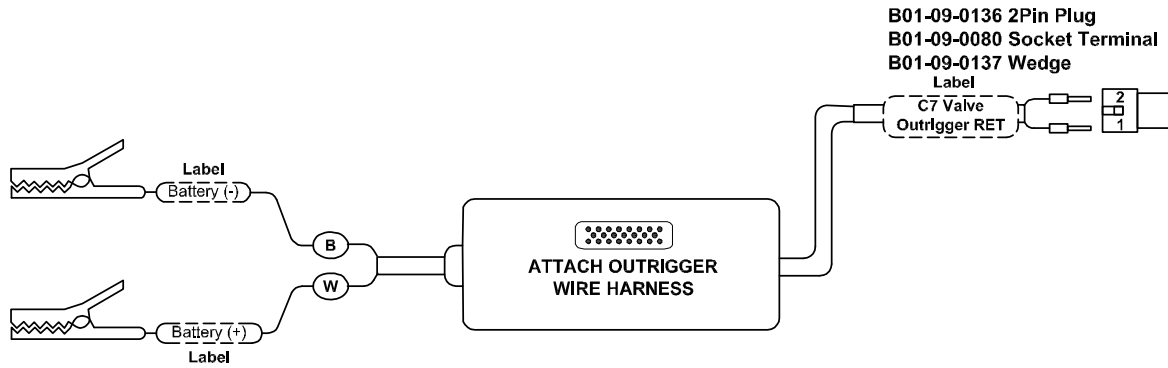

MANUAL OUTRIGGER CONTROL OPERATING INSTRUCTIONS

1. Completely lower boom(s) to stowed position. Use manual controls if necessary. See Operator's Manual.
2. Disconnect Outrigger Wire Harness from lower control box and plug cable into receptacle on Outrigger Control Box.
3. Disconnect wire harness from C7 Valve on the hydraulic manifold and replace with Outrigger controls cable.
4. Attach battery +/- clips to battery. If the battery on the lift has no charge, use an alternate 12v power source.
5. On the hydraulic manifold, completely open the proportional valve by turning counter-clockwise.
6. Insert tire Iron into receptacle on hydraulic manifold and pump to raise outriggers

HYDRAULIC PRESSURE GAUGE (B02-16-0020) OPTION

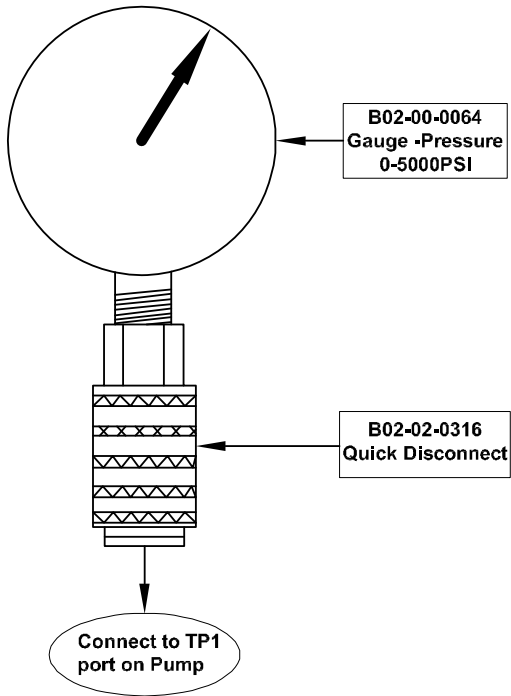

Part No.	Description	Qty
B02-00-0064	Gauge-Pressure 0-5000 PSI	1
B02-02-0316	Quick Disconnect	1

8 ANSI REPRINT

The following sections are reprinted from the ANSI A92.5-2006 code in effect at the time of manufacture and govern the safe use of the Haulotte Group | BilJax Model 55XA Articulating Boom Lift.

Permission to reprint this material has been granted by the Scaffold Industry Association.

5 RESPONSIBILITIES OF DEALERS

5.1 Basic Principles

Sound principles of safety, training, inspection, maintenance, application, and operation consistent with all data available regarding the parameters of intended use and expected environment shall be applied in the training of operators, in maintenance, application, safety provisions and operation of the aerial platform with due consideration of the knowledge that the unit will be carrying personnel.

5.2 Manuals

5.2.1 Machine Manual(s)

Dealers shall keep and maintain a copy(ies) of the:

- (1) Operating manual
- (2) Maintenance manual
- (3) Parts manual
- (4) Repair manual

The operating manual and maintenance manual shall be provided with each rental, lease, or sale delivery and shall be stored in the weather resistant storage compartment on the aerial platform. Manual(s) are considered an integral part of the aerial platform and are vital to communicate necessary safety information to owners, users and operators. In addition, repair and parts manuals should be provided with each sale delivery.

5.2.2 Manual of Responsibilities

The current Manual of Responsibilities for dealers, owners, users, operators, lessors, lessees and brokers of boom-supported elevating work platforms shall be provided and stored in the weather resistant storage compartment.

5.3 Pre-delivery Preparation

Aerial platforms shall be inspected, serviced and adjusted to manufacturer's requirements prior to each delivery by sale, lease, or rental.

5.4 Maintenance, Inspection and Repair

5.4.1 Maintenance

When a dealer accomplishes preventive maintenance on the aerial platform, it shall be in accordance with the manufacturer's recommendations and based on the environment and severity of use.

5.4.2 Inspection

When the dealer accomplishes frequent and annual inspections, they shall be in accordance with the manufacturer's manuals and instructions.

5.4.3 Repairs

Repairs accomplished to correct malfunctions and problems shall be in accordance with the manufacturer's manuals and instructions.

5.5 Maintenance Safety Precautions

Before adjustments and repairs are started on an aerial platform, the following precautions shall be taken as applicable:

- (1) Power plant stopped and starting means rendered inoperative
- (2) All controls in the "Off" position and all operating systems secured from inadvertent motion by brakes, blocks, or other means
- (3) Boom and platform lowered to the full down position, if possible, or otherwise secured by blocking or cribbing to prevent dropping
- (4) Hydraulic oil pressure relieved from all hydraulic circuits before loosening or removing hydraulic components
- (5) Safety props or latches installed where applicable as prescribed by the manufacturer

5.6 Replacement Parts

When parts or components are replaced, they shall be identical or equivalent to original aerial platform parts or components.

5.7 Training

The dealer shall offer appropriate training to facilitate owners, users, and operators to comply with requirements set forth in this standard regarding the inspection, maintenance, use, application, and operation of the aerial platform.

5.8 Familiarization upon Delivery

Upon delivery by sale, lease, rental or any form of use, the dealer shall have the responsibility with the person designated by the receiving entity for accepting the aerial platform to:

- (1) Identify the weather resistant compartment (for manual(s) storage)
- (2) Confirm that the manual(s), as specified by the manufacturer, are on the aerial platform
- (3) Review control functions
- (4) Review safety devices specific to the model aerial platform being delivered

5.9 Dealer as User

Whenever a dealer directs personnel to operate an aerial platform (loading, unloading, inspecting, sales demonstrations, or any form of use), the dealer shall assume the responsibilities of users as specified in Section 7 of this standard. All personnel authorized to operate the aerial platform shall have been:

- (1) Trained
- (2) Familiarized with the aerial platform to be operated
- (3) Made aware of the responsibilities of operators as outlined in Section 8 of this standard

5.10 Assistance to Owners and Users

If a dealer is unable to answer an owner's or user's question(s) relating to rated capacity, intended use, maintenance, repair, inspection, or operation of the aerial platform, the dealer shall obtain the proper information from the manufacturer or a qualified person if the manufacturer is no longer in business and provide that information to the owner or user.

5.11 Record Retention and Dissemination

5.11.1 Record Retention

The dealer shall retain the following records for at least four years:

- (1) Name and address of the purchaser of each aerial platform by serial number and date of delivery
- (2) Records of the pre-delivery preparation performed prior to each delivery
- (3) Records of frequent and annual machine inspections accomplished
- (4) Records of repairs accomplished to correct malfunctions and problems
- (5) Name of the person(s) trained
- (6) Name of the person(s) providing the training
- (7) Date of Training
- (8) Name of person(s) receiving familiarization with the aerial platform upon each delivery unless this individual has been provided with familiarization on the same model, or one having characteristics consistent with the one being delivered, within the prior 90 days

5.11.2 Proof of training

The dealer should provide trainees who successfully complete training a means to evidence they are trained.

The dealer shall provide such proof if requested by the trainee. The document evidencing training shall include the following information:

- (1) Name of trainee
- (2) Name of entity providing training or retraining
- (3) Name of trainer(s)
- (4) Clear identification that training covered Boom-Supported Elevating Work Platforms
- (5) Date of training

5.11.3 Record dissemination

Upon request, the dealer shall provide the following information:

- (1) To the owner of the aerial platform, a copy of frequent or annual inspections performed
- (2) To the owner of the aerial platform, a copy of repairs accomplished
- (3) To a user, proof of training for an operator, including name of trainer and date of training
- (4) To a user, the name of the person(s) receiving familiarization upon delivery of the aerial platform

5.12 Modifications

Modification, alteration or remanufacture of an aerial platform shall be made only with prior written permission of the manufacturer.

5.13 Manufacturer's safety bulletins

The dealer shall comply with safety related bulletins as received from the manufacturer.

5.14 Responsibilities upon sale

When the aerial platform is sold, the dealer:

- (1) Shall, upon delivery, ensure the operating and maintenance manuals are conveyed to the owner
- (2) Shall, upon delivery, provide a copy of the current Manual of Responsibilities
- (3) Should, within 60 days of sale, provide repair and parts manuals
- (4) Shall, within 60 days of the sale, notify the manufacturer or its successor (if existing) of the sale, providing the full name and address of the purchaser
- (5) Should, if the aerial platform is used, accomplish an annual machine inspection prior to delivery and provide a copy to the purchaser within 60 days of the sale
- (6) Shall, upon delivery, familiarize the person designated by the receiving entity with the aerial platform being acquired.

6 RESPONSIBILITIES OF OWNERS

6.1 Basic Principles

Sound principles of safety, training, inspection, maintenance, application, and operation consistent with all data available regarding the parameters of intended use and expected environment shall be applied in the performance of the responsibilities of owners with due consideration of the knowledge that the aerial platform will be carrying personnel.

6.2 Responsibilities upon Purchase

Upon purchase of the aerial platform, the buyer:

- (1) Shall ensure the operating and maintenance manuals have been received.
- (2) Should acquire repair and parts manuals within sixty days (60) of acquisition
- (3) Shall within sixty days (60) of acquisition of the aerial platform provide the manufacturer with the full name and address of the buyer along with the model and serial number of the aerial platform acquired
- (4) Shall, if the aerial platform is used, ensure the frequent inspection and annual inspections are current
- (5) Shall become familiar with and conform to the responsibilities of owners as set forth in the Manual of Responsibilities for Boom-Supported Elevating Work Platforms

6.3 Manuals

6.3.1 Machine Manual(s)

Owners shall provide a copy(ies) of the operating and maintenance manual(s) with each rental, lease, or sales delivery by ensuring they are properly stored in the weatherproof compartment that is part of the aerial platform. The manual(s) is considered an integral part of the aerial platform and is vital to communicate necessary safety information to owners, users and operators. In addition, repair and parts manual(s) should be provided with each sale delivery.

6.3.2 Manual of Responsibilities

The current Manual of Responsibilities for dealers, owners, users, operators, lessors, lessees and brokers of boom supported elevating work platforms shall be provided and stored in the weather resistant storage compartment.

6.4 Maintenance, Inspection and Repair

6.4.1 Maintenance

The owner of an aerial platform shall arrange that the maintenance specified in this standard is properly performed on a timely basis. The owner shall establish a preventive maintenance program in accordance with the manufacturer's recommendations and in accordance with the environment and severity of use of the aerial platform.

6.4.2 Inspection

The owner shall arrange for frequent and annual inspections to be performed in accordance with the recommendations of the manufacturer. All malfunctions and problems identified in the inspection shall be corrected before the aerial platform is returned to service.

6.4.3 Repairs

When the aerial platform is damaged or in need of repair, all malfunctions and problems identified shall be corrected before the aerial platform is returned to service.

6.5 Pre-delivery Preparation

Aerial platforms shall be inspected, serviced, and adjusted in accordance with the manufacturer's specifications prior to each delivery by sale, lease, or rental.

6.6 Frequent Inspection

The owner of an aerial platform shall ensure that a frequent inspection is performed in accordance with the manufacturer's instructions, on an aerial platform:

- (1) That was purchased used. This inspection shall be accomplished unless it is determined that the frequent and annual inspections are current
- (2) That has been in service for three months or 150 hours, whichever comes first
- (3) That has been out of service for a period longer than 3 months.

The inspection shall be made by a person qualified as a mechanic on the specific type aerial platform or one having similar design characteristics. The inspection shall be in accordance with items specified by the manufacturer for a frequent inspection and shall include, but not limited to the following:

- (1) All functions and their controls for speed(s), smoothness, and limits of motion
- (2) Lower controls including the provisions for overriding of upper controls
- (3) All chain and cable mechanisms for adjustment and worn or damaged parts
- (4) All emergency and safety devices
- (5) Lubrication of all moving parts, inspection of filter element(s), hydraulic oil, engine oil, and coolant as specified by the manufacturer
- (6) Visual inspection of structural components and other critical components such as fasteners, pins, shafts, and locking devices
- (7) Placards, warnings and control markings
- (8) Items specified by the manufacturer
- (9) Emergency lowering means

6.7 Annual Inspection

The owner of an aerial platform shall ensure that an annual inspection is performed on the aerial platform no later than thirteen (13) months from the date of the prior annual inspection. The inspection shall be made by a person(s) qualified as a mechanic on the specific type of aerial platform or one having similar design characteristics. The inspection shall be in accordance with items specified by the manufacturer for an annual inspection. The owner shall not place the aerial platform into service until all malfunctions and problems have been corrected.

6.8 Maintenance safety precautions

Before adjustments and repairs are started on an aerial platform, the following precautions shall be taken as applicable:

- (1) Power plant stopped and starting means rendered inoperative
- (2) All controls in the "Off" position and all operating systems secured from inadvertent motion by brakes, blocks, or other means
- (3) Elevating assembly and platform lowered to the full down position, if possible, or otherwise secured by blocking or cribbing to prevent dropping
- (4) Hydraulic oil pressure relieved from all hydraulic circuits before loosening or removing hydraulic components
- (5) Safety props or latches installed where applicable as prescribed by the manufacturer
- (6) Precautions specified by the manufacturer

6.9 Replacement parts

When parts or components are replaced, they shall be identical or equivalent to original aerial platform parts or components.

6.10 Maintenance training

The owners shall train their maintenance personnel in inspection and maintenance of the aerial platform in accordance with the manufacturer's recommendations and Sections 6.2, 6.3, 6.4, 6.5, 6.6, 6.7, 6.8, 6.9 and 6.11 of this standard and with the manufacturer's recommendations.

6.11 Training

6.11.1 Operator training

Whenever an owner directs or authorizes an employee to operate an aerial platform, (loading, unloading, inspecting or any form of use) the owner shall assume the responsibilities of the user as specified in Section 7 of this standard and shall ensure the person has been:

- (1) Trained
- (2) Familiarized with the aerial platform to be operated
- (3) Made aware of the responsibilities of operators as outlined in Section 8 of this standard

6.11.2 Assistance to user

Upon request of the user, when an owner sells, leases, rents or provides an aerial platform for any form of beneficial use, the owner at that time shall offer to do training or advise the user where training may reasonably be secured.

6.12 Familiarization upon delivery

Upon delivery for lease, rental or any form of beneficial use, the owner shall have the responsibility with the person designated by the receiving entity for accepting the aerial platform to:

- (1) Identify the weather resistant compartment (for manual(s) storage)
- (2) Confirm all manuals, as specified by the manufacturer, are on the aerial platform
- (3) Review control functions with the operator or person(s) designated by the user
- (4) Review safety devices specific to the model aerial platform being delivered

6.13 Operation

When an owner operates an aerial platform, the owner shall have the responsibilities of users as specified in Section 7 of this standard and his operating personnel shall have responsibilities of operators as specified in Section 8 of this standard.

6.14 Assistance to users and operators

If an owner is unable to answer a user's or operator's question(s) relating to rated capacity, intended use, maintenance, repair, inspection, or operation of the aerial platform, the owner shall obtain the proper information from the dealer or manufacturer and provide that information to the user or operator.

6.15 Record Retention and Dissemination

6.15.1 Record Retention

The owner shall date and retain the following records for at least 4 years:

- (1) Name and address of the purchaser of each aerial platform by serial number and date of delivery
- (2) Written records of the frequent and annual inspections performed. The record shall include deficiencies found, corrective action accomplished and identification of the person(s) performing the inspection and repairs
- (3) Written records of repairs accomplished on the aerial platform. The records shall include corrective action accomplished and identification of the person(s) performing the repairs
- (4) Pre-delivery preparation performed prior to each delivery
- (5) Name of the person(s) trained
- (6) Name of person(s) providing training
- (7) Name of person(s) receiving familiarization upon each delivery unless the individual has been provided with familiarization on the same model, or one having characteristics consistent with the one being delivered, within the prior 90 days
- (8) Name of person(s) providing familiarization upon delivery

6.15.2 Proof of Training

Owners providing training should provide successful trainees a means to evidence their training and shall provide such proof if requested by the trainee. The document evidencing training shall include the following information:

- (1) Name of entity providing training or retraining
- (2) Name of trainer(s)
- (3) Clear identification that training covered Boom-Supported Elevating Work Platforms
- (4) Date of training
- (5) Name of trainee

6.15.3 Record dissemination

Upon request, an owner accomplishing training and/or familiarization shall provide the following:

- (1) To a user, proof of training for an operator, including name of trainer and date of training
- (2) To a user, the name of the person(s) receiving familiarization upon delivery of the aerial platform

6.16 Modifications

The owner shall not modify or concur in modification or alteration to the aerial platform without the modifications being approved and certified in writing by the manufacturer.

6.17 Manufacturer's Safety Bulletins

The owner shall comply with safety related bulletins as received from the manufacturer or dealer.

6.18 Responsibilities upon Sale

Upon sale of the aerial platform, the seller:

- (1) Shall, upon delivery, ensure the operating and maintenance manuals are conveyed to the new owner
- (2) Shall, upon delivery, provide a copy of the current Manual of Responsibilities to the new owner
- (3) Should provide repair and parts manuals to the new owner
- (4) Shall, upon the request of the new owner, offer training or advise where training may reasonably be obtained

7 RESPONSIBILITIES OF USERS

7.1 Basic principles

The information in this standard must be supplemented by good job management, safety control, and the application of sound principles of safety, training, inspection, maintenance, application and operation, consistent with all data available regarding the parameters of intended use and expected environment. Since the user has direct control over the application and operation of aerial platforms, conformance with good safety practices in this area is the responsibility of the user and the operating personnel, including the operator. Decisions on the use and operation of the aerial platform must always be made with due consideration for the fact that the aerial platform will be carrying personnel whose safety is dependent on those decisions.

7.2 Manuals

7.2.1 Machine manuals

Users shall keep and maintain a copy(ies) of the operating and maintenance manual(s) in the weather resistant storage compartment provided by the manufacturer. The manual(s) is considered an integral part of the aerial platform and is vital to communicate necessary safety information to users and operators.

7.2.2 Manual of Responsibilities

The current Manual of Responsibilities for dealers, owners, users, operators, lessors, lessees and brokers of boom supported elevating work platforms shall be provided and stored in the weather resistant storage compartment.

7.3 Inspection and Maintenance

Users shall inspect and maintain the aerial platform as required to ensure proper operation. The frequency of inspection and maintenance shall be determined by the manufacturer's recommendations and be compatible with operating conditions and the severity of the operating environment. Aerial platforms that are not in proper operating condition shall be immediately removed from service until repaired. Repairs shall be made by a qualified person and the repairs shall be in conformance with the manufacturer's recommendations.

7.3.1 Frequent Inspection

Users of an aerial platform shall ensure that frequent inspections are conducted as outlined in Section 6.6 of this standard.

7.3.2 Annual Inspection

Users of an aerial platform shall ensure that annual inspections are conducted as outlined in Section 6.7 of this standard.

7.3.3 Pre-start inspection

Before use each day or at the beginning of each shift, the aerial platform shall be given a visual inspection and functional test including, but not limited to, the following:

- (1) Operating and emergency controls
- (2) Safety devices
- (3) Air, hydraulic and fuel system leaks
- (4) Cables and wiring harness
- (5) Loose or missing parts
- (6) Tires and wheels
- (7) Placards, warnings, control markings, and operating manual(s)
- (8) Outriggers, stabilizers, extendable axles and other structures
- (9) Guardrail system
- (10) Items specified by the manufacturer

7.3.4 Maintenance Safety Precautions

Before adjustments and repairs are started on an aerial platform, the following precautions shall be taken as applicable:

- (1) Power plant stopped and starting means rendered inoperative
- (2) All controls in the "Off" position and all operating systems secured from inadvertent motion by brakes, blocks, or other means
- (3) Boom and platform lowered to the full down position, if possible, or otherwise secured by blocking or cribbing to prevent dropping
- (4) Hydraulic oil pressure relieved from all hydraulic circuits before loosening or removing hydraulic components
- (5) Safety props or latches installed where applicable as prescribed by the manufacturer
- (6) Precautions specified by the manufacturer

7.4 Replacement Parts

When parts or components are replaced, they shall be identical or equivalent to original aerial platform parts or components.

7.5 Maintenance Training

The user shall ensure only qualified personnel inspect and maintain the aerial platform in accordance with the manufacturer's recommendations and Section 7.3, 7.4 and 7.6 of this standard and with the manufacturer's recommendations.

7.6 Operator Training and Retraining

Whenever a user directs or authorizes an individual to operate an aerial platform, the user shall ensure that the person has been:

- (1) Trained before being assigned to operate the aerial platform
- (2) Familiarized with the aerial platform to be operated
- (3) Made aware of responsibilities of operators as outlined in Section 8 of this standard
- (4) Retrained, if necessary, based on the user's observation and evaluation of the operator

7.6.1 Trainee Records

A record of the trainee's aerial platform instruction shall be maintained by the user for at least four (4) years.

7.7 Familiarization Before Use

The user shall permit only properly trained personnel to operate an aerial platform. The user shall ensure that before use the operator is familiar with the model of the aerial platform to be operated, and specifically:

- (1) Knows where the weather resistant compartment for manual(s) storage is located
- (2) Knows the operating and maintenance manuals supplied by the manufacturer are stored in the weather resistant compartment and is familiar with the operating and safety manuals
- (3) Understands all control functions, placards and warnings
- (4) Is aware of and understands all safety devices specific to the model aerial platform being used

7.8 Work Place Inspection

Before the aerial platform is used and during use, the user shall check the area in which the aerial platform is to be used for possible hazards such as, but not limited to:

- (1) Drop-offs or holes, including those concealed by water, ice, mud, etc.
- (2) Slope(s)
- (3) Bumps and floor obstructions
- (4) Debris
- (5) Overhead obstructions and electrical conductors
- (6) Hazardous locations and atmospheres (reference ANSI/NFPA 505-1996)
- (7) Inadequate surface and support to withstand all load forces imposed by the aerial platform in all operating configurations
- (8) Wind and weather conditions
- (9) Presence of unauthorized persons
- (10) Other possible unsafe conditions

7.9 Determination of Hazardous Locations

It shall be the responsibility of the user to determine the hazard classification of the intended location of operation. Aerial platforms operated in hazardous locations shall be approved in accordance with, and of the type required, by ANSI/NFPA 505-1996.

7.10 Operator Warnings and Instructions

The user shall direct personnel operating the aerial platform to be in compliance with the provisions set forth in this standard. The user shall monitor their performance and supervise their work to ensure the use, application, and operation of the aerial platform is in conformance with the provisions set forth in Section 8 of this standard, warn personnel of potential hazards, provide means to protect against identified hazards, and explain the potential consequences of not following proper operating guidelines. Instructions and guidelines regarding proper operation shall include, but not necessarily be limited to the following issues and subjects:

- (1) Fall Protection. Principal fall protection is provided by the guardrail system. The user shall direct and monitor the operator to ensure that all components of the guardrail system are in place. The user shall direct and monitor occupants of the work platform to ensure that they wear a personal fall arrest system to protect against the potential effects of ejection or a fall restraint system to prevent free fall.

(a) Election of Systems:

The user may elect to use either a restraint or an arrest system

1. Fall Restraint Systems – An anchorage, belt or harness and a lanyard which prevent free fall. These systems are arranged to keep occupants in the platform in the event of dynamic forces which might cause ejection.

(1.1) Occupants shall use a restraint system to keep the occupant(s) within the platform.

7.10 Operator Warnings and Instructions (Continued)

(1.2) Restraint systems may include either belts or harnesses and do not include arresting or deceleration devices.

2. Fall Arrest System – An anchorage, full body harness and a lanyard used to arrest an employee in a fall from an aerial platform. Such systems allow a fall over the guardrail system. The force applied to the body shall be limited to 1800 lbs. (8,000N).

(2.1) A fall arrest system shall allow workers to move around the platform but provide a minimum of lanyard slack.

(2.2) A fall arrest system for aerial lifts shall include a lanyard, and full body harness. A deceleration device if used will not allow a fall further than that required to arrest the fall without exceeding 1800 lbs. (8,000N) of force on the worker. Fall arrest systems, beyond the anchorage, are not part of the aerial work platform and are to be specified and supplied by the user of the aerial work platform.

- (2) Slope and grade. The aerial platform shall not be operated in any manner on grades, side slopes or ramps exceeding those for which the aerial platform is rated by the manufacturer.
- (3) Deployment of stability enhancing means. Outriggers, stabilizers, extendable axles, oscillating axles or other stability enhancing means shall be deployed and locked into place as required by the manufacturer.
- (4) Guardrail system. Guardrails shall be installed and positioned, and access gates or openings shall be properly closed per the manufacturer's instructions.
- (5) Distribution of load. The load and its distribution on the platform and any platform extension(s) shall be in accordance with the manufacturer's rated capacity for that specific configuration.
- (6) Maintaining overhead clearance. The operator shall be instructed to ensure that adequate clearance is maintained from overhead obstructions and energized electrical conductors and parts.
- (7) Electrocutation hazard. All applicable safety related work practices intended to prevent electric shock covered by the Code of Federal Regulations (CFR) 1910.333 shall be defined and explained to the operator by a qualified person. In particular, such person shall direct the operator commensurate with the operators qualifications to maintain the minimum approach distance (MAD) from energized power lines and covered by CFR1910.333c.
- (8) Personal protective equipment (PPE). The user shall direct the operator to ensure all personnel on the platform wear personal protective equipment (PPE) as required.
- (9) Personnel footing. Personnel shall maintain a firm footing on the platform floor while working thereon. Climbing by occupants on the mid-rail or top-rail of the aerial platform is prohibited. The use of planks, ladders, or any other devices on the platform for achieving additional height or reach is prohibited.
- (10) Precaution for other moving equipment. When other moving equipment and vehicles are present, special precautions shall be taken to comply with local ordinances or safety standards established for the workplace.

Warnings such as, but not limited to, flags, roped off areas, flashing lights, and barricades shall be used as appropriate.

- (11) Reporting problems or malfunctions. The user shall direct the operator to immediately report to a supervisor any problem(s) or malfunction(s) that become evident during operation. The user shall ensure all problems and malfunctions that affect the safety of operations are repaired prior to continued use.
- (12) Reporting potentially hazardous locations. The user shall direct the operator to immediately report to a supervisor any potentially hazardous location(s) that become evident during operation.

7.10 Operator Warnings and Instructions (Continued)

- (13) Hazardous location operation. Operation of aerial platforms not approved and marked for operation in a hazardous location shall be prohibited.
- (14) Entanglement. Care shall be taken to prevent rope, electric cords, and hoses, etc., from becoming entangled in the aerial platform.
- (15) Capacity limitations. Rated capacities and rated number of occupants shall not be exceeded when loads are transferred to the platform at any height.
- (16) Work area. The user shall direct the operator to ensure the area surrounding the aerial platform is clear of personnel and equipment before lowering the platform.
- (17) Fueling. The engine (if applicable) shall be shut down while fuel tanks are being filled. Fueling shall be done in a well ventilated area free of flame, sparks, or other hazards that may cause fire or explosion.
- (18) Battery charging. Batteries shall be charged in a well ventilated area free of flame, sparks, or other hazards that may cause fire or explosion.
- (19) Improper platform stabilization. The aerial platform shall not be positioned against another object to steady the platform or improve stability.
- (20) Misuse as a crane. The aerial platform shall not be used as a crane.
- (21) Unusual operating support conditions. The aerial platform shall not be operated from a position on trucks, trailers, railway cars, floating vessels, scaffolds, or similar equipment unless the application is approved in writing by the manufacturer or a qualified person.
- (22) Travel speeds. The user shall direct the operator to limit travel speed according to conditions, including the condition of the support surface, congestion, visibility, slope, location of personnel, and other factors leading to hazards which may cause collision(s) or result in potential injury(ies) to personnel.
- (23) Driving requirements. Before and during driving while the platform is elevated, the user shall direct the operator to:
 - (a) Maintain a clear view of the support surface and route of travel
 - (b) Ensure personnel in the worksite area that may be affected are aware of the movement, communicating and maneuvering the aerial platform as required to protect against personal injury
 - (c) Maintain a safe distance from obstacles, debris, drop-offs, holes, depressions, ramps, and other hazards to ensure safe travel
 - (d) Maintain a safe distance from overhead obstructions and energized electrical conductors.
- (24) Stunt driving. Stunt driving and horseplay are prohibited.
- (25) Securing the aerial platform. The user shall direct the operator to implement means provided to protect against use by an unauthorized person(s).
- (26) Altering safety devices. Interlocks or other safety devices shall not be altered or disabled.
- (27) Snagged platform. If the platform or elevating assembly becomes caught, snagged, or otherwise prevented from normal motion by adjacent structures or other obstacles such that control reversal does not free the platform, all personnel shall be removed from the platform before attempts are made to free the platform using lower controls.
- (28) Vacating (or entering) an elevated aerial platform. If permitted by the manufacturer, personnel shall only vacate or enter a raised aerial platform by following the guidelines and instructions provided by the manufacturer.

7.10 Operator Warnings and Instructions (Continued)

- (29) Modifications. Modification or alteration of an aerial platform or the fabrication and attaching of frameworks, or the mounting of attachments for holding tools or materials onto the platform or the guardrail system shall only be accomplished with the prior written permission of the manufacturer.
- (30) Assistance to the operator. If an operator encounters any suspected malfunction of the aerial platform, or any hazard or potentially unsafe condition relating to capacity, intended use or safe operation of the aerial platform, the operator shall cease operation of the aerial platform and request further information from the user.
- (31) Problems or malfunctions. Any problem(s) or malfunction(s) that affect the safety of operations shall be repaired prior to the use of the aerial platform.
- (32) Carrying materials (larger than the platform). The user shall ensure that only properly secured tools and materials which are evenly distributed and can be safely handled by a person(s) working from the platform, are moved.
- (33) Rated horizontal force. The user shall direct the operator not to exceed the manufacturer's rated horizontal force.
- (34) Bridge cranes. When an aerial platform is to operate within the area of travel of a bridge crane or similar equipment, steps shall be taken to prevent a collision with the aerial platform.
- (35) Adequate support requirements. The user shall ensure the support surface is adequate for the aerial platform and the load carried.
- (36) Leveling the aerial platform. Outriggers and leveling devices supplied by the manufacturer shall be utilized to level the aerial platform when provided.
- (37) Protecting against unauthorized use. The user shall direct the operator not to use, rent, lease, or provide the aerial platform for any form of beneficial use unless so authorized.

7.11 User as Operator

If a user is also the operator of an aerial platform, the user shall have the responsibilities of operators specified in Section 8 of this standard as well as responsibilities of users as specified in Section 7 of this standard.

7.12 Shutdown of Aerial Platform

The user shall authorize and direct the operating personnel to cease operation of the aerial platform in case of any suspected malfunction(s) of the aerial platform, or any hazard or potentially unsafe condition(s) that may be encountered and to request further information as to safe operation from the owner, dealer, or manufacturer before further operation of the aerial platform.

7.13 Record Retention and Dissemination.

7.13.1 Record Retention

The user shall retain the following records for at least 4 years:

- (1) Names of the operator(s) trained and retrained
- (2) Names of operator(s) provided familiarization
- (3) The owner (or the entity designated by the owner) is responsible to ensure frequent and annual inspections are conducted and written records are maintained. The records shall include the date of the inspection, any deficiencies found, the corrective action recommended and identification of the person(s) performing the inspection
- (4) When employees of the user accomplish repairs on the aerial platform, the user shall maintain written records. The record shall include the date of repair, a description of the work accomplished and identification of the person(s) performing the repair

7.13.2 Record Dissemination

- (1) When the user directs personnel to accomplish frequent or annual inspections, not later than 60 days after the inspections, the appropriate records shall be provided to the owner of the aerial platform
- (2) When the user directs personnel to accomplish repairs on the aerial platform, not later than 60 days after the repairs are accomplished, the appropriate records shall be provided to the owner

7.13.3 Proof of Training

Users providing training should provide successful trainees a means to evidence their training and shall provide such proof if requested by the trainee.

The document evidencing training shall include the following information:

- (1) Name of entity providing training or retraining
- (2) Name of trainer(s)
- (3) Clear identification that training covered Boom-Supported Elevating Work Platforms
- (4) Date of training
- (5) Name of trainee

7.14 Modifications

Modification, alteration or remanufacture of an aerial platform shall be made only with prior written permission of the manufacturer.

7.15 Manufacturer's Safety Bulletins

The user shall comply with safety related bulletins as received from the manufacturer, dealer, or owner.

8 RESPONSIBILITIES OF OPERATORS

8.1 Basic Principles

The information in this standard shall be supplemented by good judgment, safety control, and caution in evaluating each situation. Since the operator is in direct control of the aerial platform, conformance with good safety practices in this area is the responsibility of the operator. The operator shall make decisions on the use and operation of the aerial platform with due consideration for the fact that his or her own safety as well as the safety of others is dependent on those decisions.

8.2 Manuals

8.2.1 Machine Manuals

The operator shall ensure the operating and maintenance manuals are stored in the weather resistant storage compartment on the aerial platform. The manual(s) is considered an integral part of the aerial platform and is vital to communicate necessary safety information to the operator. The operator shall be familiar with the manuals and reference them as required.

8.2.2 Manual of Responsibilities

The operator shall be familiar with the requirements for operators as set forth in Section 8 of the Manual of Responsibilities for Dealers, Owners, Users, Operators, Lessors, Lessees and Brokers of Boom-Supported Elevating Work Platforms. The current Manual of Responsibilities shall be kept with the aerial platform at all times and stored in the weather-resistant compartment when not in use.

8.3 Prestart Inspection

Before use each day or at the beginning of each shift, the aerial platform shall be given a visual inspection and functional test including, but not limited to, the following:

- (1) Operating and emergency controls
- (2) Safety devices
- (3) Personal protective devices
- (4) Air, hydraulic and fuel system(s) leaks
- (5) Cables and wiring harness
- (6) Loose or missing parts
- (7) Tires and wheels
- (8) Placards, warnings, control markings and operating manual(s)
- (9) Outriggers, stabilizers, extendable axles and other structures
- (10) Guardrail system
- (11) Items specified by the manufacturer

8.4 Problems or malfunctions

Any problems or malfunctions that affect the safety of operations shall be repaired prior to the use of the aerial platform.

8.5 Training, Retraining, and Familiarization

8.5.1 General Training

Only personnel who have received general instructions regarding the inspection, application and operation of aerial platforms, including recognition and avoidance of hazards associated with their operation, shall operate an aerial platform. Such items covered shall include, but not necessarily be limited to, the following issues and requirements:

- (1) The purpose and use of manuals
- (2) That operating manuals are an integral part of the aerial platform and must be stored properly in the weather resistant compartment when not in use
- (3) A pre-start inspection
- (4) Responsibilities associated with problems or malfunctions affecting the operation of the aerial platform
- (5) Factors affecting stability
- (6) The purpose of placards and decals
- (7) Workplace inspection
- (8) Safety rules and regulations
- (9) Authorization to operate
- (10) Operator warnings and instructions
- (11) Actual operation of the aerial platform

Under the direction of a qualified person, the trainee shall operate the aerial platform for a sufficient period of time to demonstrate proficiency in the actual operation of the aerial platform.

8.5.2 Retraining

The operator shall be retrained, when so directed by the user, based on the user's observation and evaluation of the operator.

8.5.3 Familiarization

When an operator is directed to operate an aerial platform he/she is not familiar with, the operator shall receive instructions regarding the following items:

- (1) The location of the weather resistant compartment (for manual(s) storage)
- (2) The purpose and function of all controls
- (3) Safety devices and operating characteristics specific to the aerial platform

8.6 Before Operation

Before operation, the operator shall:

- (1) Read and understand the manufacturer's operating instruction(s) and user's safety rules, or have them explained
- (2) Understand all labels, warnings, and instructions displayed on the aerial platform or have them explained
- (3) Ensure all occupants of the aerial platform wear appropriate personal protective equipment (PPE) for the conditions, including the environment in which the aerial platform will be operated

8.7 Workplace Inspection

Before the aerial platform is used and during use, the operator shall check the area in which the aerial platform is to be used for possible hazards such as, but not limited to:

- (1) Drop-offs or holes, including those concealed by water, ice, mud, etc.
- (2) Slope(s)
- (3) Bumps and floor obstructions
- (4) Debris
- (5) Overhead obstructions and electrical conductors
- (6) Hazardous locations and atmospheres (reference ANSI/NFPA 505-1987)
- (7) Inadequate surface and support to withstand all load forces imposed by the aerial platform in all operating configurations
- (8) Wind and weather conditions
- (9) Presence of unauthorized persons
- (10) Other possible unsafe conditions

8.8 Prior to each operation

Before each operation of the platform, the operator shall ensure:

- (1) Outriggers, stabilizers, extendable axles, or other stability enhancing means, are used as required by the manufacturer
- (2) Guardrails are installed and access gates or openings are closed per manufacturer's instructions
- (3) The load and its distribution on the platform and any platform extension(s) are in accordance with the manufacturer's rated capacity for that specific configuration
- (4) All personnel on the aerial platform have appropriate safety gear for the work and environment envisioned

8.9 Understanding of Hazardous Locations

It shall be the responsibility of the operator to understand the hazard classification of the intended location of operation according to ANSI/NFPA 505-1996.

8.10 Operator warnings and instructions

The operator shall direct personnel operating the aerial platform to be in compliance with the provisions set forth in this standard. The operator shall monitor their performance and supervise their work to ensure the use, application, and operation of the aerial platform is in conformance with the provisions set forth in Section 8 of this standard, warn personnel of potential hazards, provide means to protect against identified hazards, and explain the potential consequences of not following proper operating guidelines. Instructions and guidelines regarding proper operation shall include, but not necessarily be limited to the following issues and subjects:

- (1) Fall protection. While the guardrail system of the aerial platform provides primary fall protection all occupants of the work platform shall wear either fall restraint or fall arrest equipment as directed by their employer.
- (2) Slope and grade. The aerial platform shall not be operated in any manner on grades, side slopes, or ramps exceeding those for which the aerial platform is rated by the manufacturer.
- (3) Deployment of stability enhancing means. Outriggers, stabilizers, extendable axles or other stability enhancing means shall be deployed and locked into place as required by the manufacturer.
- (4) Guardrail system. Guardrails shall be installed and positioned, and access gates or openings shall be properly closed per the manufacturer's instructions.
- (5) Distribution of load. The load and its distribution on the platform and any platform extension(s) shall be in accordance with the manufacturer's rated capacity for that specific configuration.
- (6) Maintaining overhead clearance. The operator shall be instructed to ensure that adequate clearance is maintained from overhead obstructions and energized electrical conductors and parts.
- (7) Electrocution hazard. The operator shall perform only the work for which he or she is qualified, in compliance with all applicable safety related work practices intended to prevent electric shock covered by the Code of Federal Regulations (CFR) 1910.333. The operator's level of competence shall be established only by persons qualified to do so. Operators shall maintain the appropriate minimum approach distance (MAD) from energized power lines and parts covered by CFR 1910.333 (c)
- (8) Personal Protective Equipment. The operator shall ensure all personnel on the platform wear personal protective equipment as required.
- (9) Personnel footing. Personnel shall maintain a firm footing on the platform floor while working thereon. Climbing by occupants on the mid-rail or top-rail of the aerial platform is prohibited. The use of planks, ladders, or any other devices on the platform for achieving additional height or reach is prohibited.
- (10) Precaution for other moving equipment. When other moving equipment and vehicles are present, special precautions shall be taken to comply with local ordinances or safety standards established for the workplace.
Warnings such as, but not limited to, flags, roped off areas, flashing lights, and barricades shall be used as appropriate.
- (11) Reporting problems or malfunctions. The operator shall immediately report to a supervisor any problem(s) or malfunction(s) that become evident during operation. The operator shall ensure all problems and malfunctions that affect the safety of operations are repaired prior to continued use.
- (12) Reporting potentially hazardous locations. The operator shall immediately report to a supervisor any potentially hazardous location(s) that become evident during operation.
- (13) Hazardous location operation. Operation of aerial platforms not approved and marked for operation in a hazardous location shall be prohibited.
- (14) Entanglement. Care shall be taken to prevent rope, electric cords, and hoses, etc., from becoming entangled in the aerial platform.

8.10 Operator warnings and instructions (Continued)

- (15) Capacity limitations. Rated capacities shall not be exceeded when loads are transferred to the platform at any height.
- (16) Work area. The operator shall ensure the area surrounding the aerial platform is clear of personnel and equipment before lowering the platform.
- (17) Fueling. The engine (if applicable) shall be shut down while fuel tanks are being filled.
Fueling shall be done in a well-ventilated area free of flame, sparks, or other hazards that may cause fire or explosion.
- (18) Battery charging. Batteries shall be charged in a well ventilated area free of flame, sparks or other hazards that may cause fire or explosion.
- (19) Improper platform stabilization. The aerial platform shall not be positioned against another object to steady the platform or improve stability.
- (20) Misuse as a crane. The aerial platform shall not be used as a crane.
- (21) Unusual operating support conditions. The aerial platform shall not be operated from a position on trucks, trailers, railway cars, floating vessels, scaffolds, or similar equipment unless the application is approved in writing by the manufacturer or a qualified person.
- (22) Travel speeds. The operator shall limit travel speed according to conditions, including the condition of the support surface, congestion, visibility, slope, location of personnel, and other factors leading to hazards which may cause collision(s) or result in potential injury(ies) to personnel.
- (23) Driving requirements. Before and during driving while the platform is elevated, the operator shall:
 - (a) Maintain a clear view of the support surface and route of travel
 - (b) Ensure personnel in the worksite area that may be affected are aware of the movement, communicating and maneuvering the aerial platform as required to protect against personal injury
 - (c) Maintain a safe distance from obstacles, debris, drop-offs, holes, depressions, ramps, and other hazards to ensure safe travel
 - (d) Maintain a safe distance from overhead obstacles
- (24) Stunt driving. Stunt driving and horseplay are prohibited.
- (25) Securing the aerial platform. The operator shall implement means provided to protect against use by an unauthorized person(s).
- (26) Altering safety devices. Interlocks or other safety devices shall not be altered or disabled.
- (27) Snagged platform. If the platform or elevating assembly becomes caught, snagged, or otherwise prevented from normal motion by adjacent structures or other obstacles such that control reversal does not free the platform, all personnel shall be removed from the platform before attempts are made to free the platform using lower controls.
- (28) Vacating (or entering) an elevated aerial platform. If permitted by the manufacturer, personnel shall only vacate or enter a raised aerial platform by following the guidelines and instructions provided by the manufacturer.
- (29) Modifications. Modification or alteration of an aerial platform or the fabrication and attaching of frameworks or the mounting of attachments for holding tools or materials onto the platform or the guardrail system shall only be accomplished with the prior written permission of the manufacturer.
- (30) Assistance to the operator. If an operator encounters any suspected malfunction of the aerial platform, or any hazard or potentially unsafe condition relating to capacity, intended use or safe operation of the aerial platform, the operator shall cease operation of the aerial platform and request further information from the operator.

8.10 Operator warnings and instructions (Continued)

- (31) Problem(s) or malfunction(s). Any problems or malfunctions that affect the safety of operations shall be repaired prior to the use of the aerial platform.
- (32) Carrying materials (larger than the platform.) The operator shall ensure that only properly secured tools and materials which are evenly distributed and can be safely handled by a person(s) working from the platform, shall be moved.
- (33) Rated horizontal force. The operator shall not exceed the manufacturer's rated horizontal force.
- (34) Bridge cranes or contact with any electrical conductors. When an aerial platform is to operate within the area of travel of a bridge crane or similar equipment, steps shall be taken to prevent a collision with the aerial platform.
- (35) Adequate support requirements. The operator shall insure the support surface is adequate for the aerial platform and the load carried.
- (36) Leveling the aerial platform. Outriggers and leveling devices supplied by the manufacturer shall be utilized to level the aerial platform when provided.
- (37) Protecting against unauthorized use. The operator shall not use, rent, lease, or provide the aerial platform for any form of beneficial use unless so authorized.

8.11 Record of training

When provided or when obtained upon the operator's request, proof of training by the training entity should be retained by the operator. Records shall contain the following information:

- (1) Name of entity providing training or retraining
- (2) Name of trainer(s)
- (3) Clear identification that training covered Boom-Supported Elevating Work Platforms
- (4) Date of training
- (5) Name of trainee

9 RESPONSIBILITIES OF LESSORS

9.1 Basic principles

Sound principles of safety, training inspections, maintenance, application, and operation consistent with all data available regarding the parameters of intended use and expected environment shall be applied in the performance of responsibilities of lessors with due consideration of the knowledge that the aerial platform will be carrying personnel.

9.2 Lessor as a Dealer

When a lessor uses the aerial platform as a dealer, the lessor shall have the responsibilities of dealers as specified in Section 5 of this standard.

9.3 Lessor as an Owner

When a lessor uses the aerial platform as an owner, the lessor shall have the responsibilities of owners as specified in Section 6 of this standard.

9.4 Lessor as a User

When a lessor uses the aerial platform as a user, the lessor shall have the responsibilities of users as specified in Section 7 of this standard.

9.5 Lessor as an Operator

When a lessor uses the aerial platform as an operator, the lessor shall have the responsibilities of operators as specified in Section 8 of this standard.

10 RESPONSIBILITIES OF LESSEES

10.1 Basic Principles

Sound principles of safety, training, inspections, maintenance, application, and operation consistent with all data available regarding the parameters of intended use and expected environment shall be applied in the performance of responsibilities of lessees with due consideration of the knowledge that the aerial platform will be carrying personnel.

10.2 Lessee as a Dealer

When a lessee uses the aerial platform as a dealer, the lessee shall have the responsibilities of dealers as specified in Section 5 of this standard.

10.3 Lessee as an Owner

When a lessee uses the aerial platform as an owner, the lessee shall have the responsibilities of owners as specified in Section 6 of this standard.

10.4 Lessee as a User

When a lessee uses the aerial platform as a user, the lessee shall have the responsibilities of users as specified in Section 7 of this standard.

10.5 Lessee as an Operator

When a lessee uses the aerial platform as an operator, the lessee shall have the responsibilities of operators as specified in Section 8 of this standard.

11 RESPONSIBILITIES OF BROKER

11.1 Responsibilities upon sale

The broker shall:

- (1) Upon delivery, ensure the operating and maintenance manuals are provided to the new owner
- (2) Upon delivery, provide a copy of the current Manual of Responsibilities to the new owner
- (3) Maintain records of the sale for a minimum of four (4) years

11.2 Responsibilities with Re-rents, Leases, or Any Other Form of Beneficial Use

When compensation is received as a result of a re-rent, lease or any form of beneficial use of an aerial platform, the broker shall:

- (1) Upon delivery, ensure the operating and maintenance manuals are provided to the user
- (2) Upon delivery, provide a copy of the current Manual of Responsibilities
- (3) Ensure operating personnel are familiarized with the aerial platform prior to use
- (4) Retain records of the transaction for a minimum of four (4) years

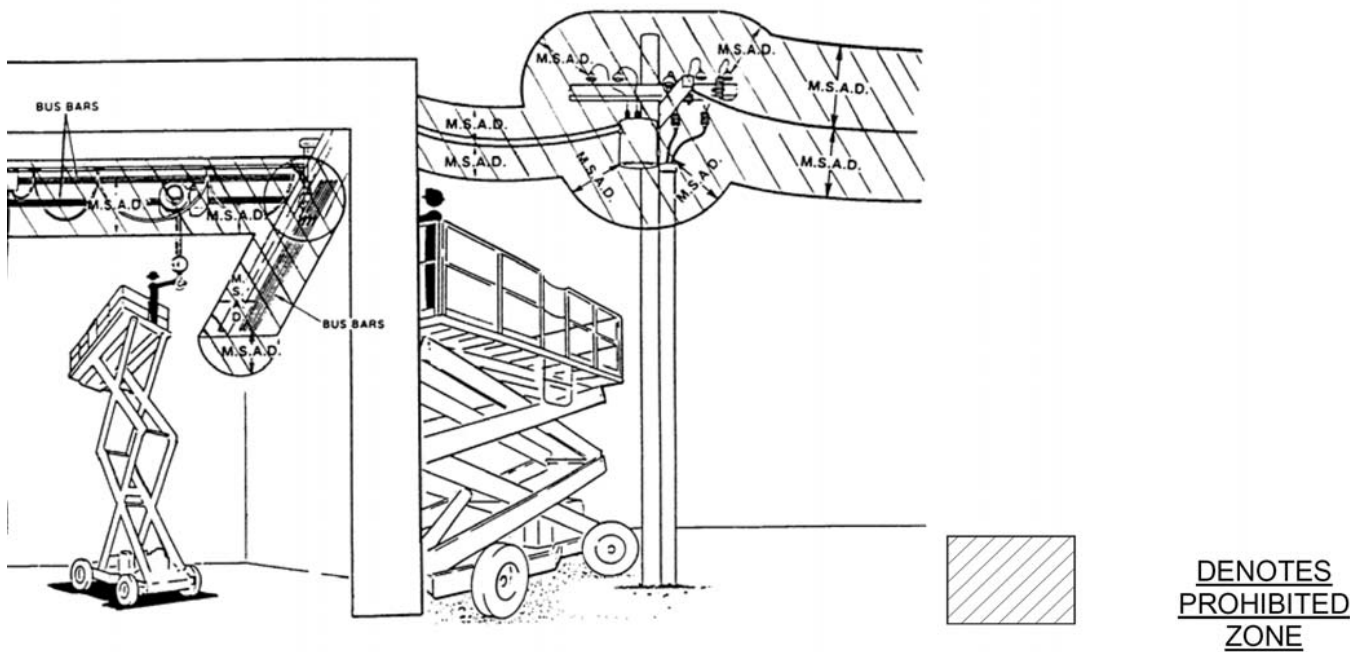

Figure 8-1 Minimum Safe Approach Distances

MINIMUM SAFE APPROACH DISTANCES

Voltage Range (Phase to Phase)	Minimum Safe Approach Distance	
	(Feet)	(Meters)
0 to 300V	Avoid Contact	
Over 300V to 50KV	10	3.05
Over 50KV to 200KV	15	4.60
Over 50KV to 200KV	20	6.10
Over 200KV to 350KV	25	7.62
Over 350KV to 500KV	35	10.67
Over 500KV to 750KV	45	13.72

⚡ DANGER

Do not allow machine, personnel, or conductive materials inside prohibited zone. Maintain M.S.A.D. from all energized lines and parts as well as those shown. Assume all electrical parts and wires are energized unless known otherwise.

⚠ WARNING

Diagrams shown are only for purposes of illustrating M.S.A.D. work positions, not all work positions.

INSPECTION FORM for Haulotte Group | BilJax X-Boom Aerial Work Platforms

Machine Model #.:	55XA
Date of Manufacture:	
Date of Inspection:	

Serial No.:	
Inspection Performed by:	
Inspection Location:	

Inspection and Maintenance of the above listed machine shall be performed only by fully trained, authorized and, where applicable, certified personnel. All service checks shall be performed in accordance with manufacturer's recommendations (see Sections 3 thru 5 of this Parts and Service Manual) and ANSI/SIA A92.5-2006. Copy this form as needed. Direct any questions to the BilJax Customer Service Department: 1.800.537.0540.

Inspector: Initial in the space provided beside each service check as it is completed. Sign and date form after Inspection.

Owner: Initial in the space provided beside each service check as it is completed. Sign and date form after Inspection.

Frequency Key: D=Daily (or before each use); W=Weekly; M=Monthly; A=Annually

Service Check Description	Frequency	Initials
Verify that all decals are correctly applied and in plain view.	D	
Verify that all controls and indicators at ground and platform control stations operate properly.	D	
Verify proper tire inflation.	D	
Inspect tires for loose, damaged or missing lug nuts.	D	
Inspect structural components for obvious damage or debris.	D	
Inspect machine for loose, damaged or missing fasteners, including pins and bolts.	D	
Verify that boom down limit switches operate correctly.	D	
Verify that outrigger safety interlocks operate correctly.	D	
Inspect hydraulic system and fluid levels.	W	
Check battery electrolyte level.	W	
Inspect electrical wiring	W	
Inspect boom for missing, loose or damaged hardware.	W	
Inspect all hydraulic system components including pump and motor and cylinders for damage, leaks, loss of pressure or speed, and unusual noise or vibration.	W	
Clean all battery terminals.	M	
Check battery connections.	M	
Verify proper operation of manual lowering valves and hand pump.	M	
Lubricate all compartment hinges and latches, slew ring and mating gear using NLGI Grade 2 multi-purpose grease.	M	
Check Wheel Nut torque.	M	
Replace Hydraulic Oil and Hydraulic Filter.	A	
Inspect pivot pins and cylinders, including rod ends for wear or damage.	A	
Visually inspect all welds for wear, damage or corrosion.	A	
Inspect outriggers for wear or damage.	A	
Verify proper level sensor operation	A	
Inspect and adjust axles and parking brake.	A	
Load test all boom functions with a 500lb (227kg) load (440lb/200kg load if machine is equipped with jib/platform rotate).	A	
Check slew ring for wear or damage.	A	

Inspector Signature _____ **Date** ____ / ____ / ____

Haulotte 
G R O U P

BILJAX

125 Taylor Parkway
Archbold, Ohio 43502
Phone : (800) 537-0540
(419) 445-8915
Fax. : (419) 445-0367

Distributed by:

--