

3522 A



3522 A	
Working height	41 ft 9 in (12.9 m)
Maximum platform height	35 ft 9 in (10.9 m)
Horizontal outreach	
Maximum (from centerline)	19 ft (5.8 m)
Maximum (from edge of footpad)	17 ft 5 in (5.3 m)
Up and over height	19 ft (5.8 m)
Turntable rotation	700° non-continuous
Load capacity	500 lb (227 kg)

- Telescopic upper boom and platform jib
- Negative angle upper boom

Standard Equipment and Features

Air Line to Platform ⁴

Featuring a 3/8-inch diameter, 300 psi rated nylon braided air hose and includes both a 1/4-inch and a 3/8-inch universal female coupler that can be attached to the hose end at the platform bulkhead, ensuring that you'll always be able to connect your tools to air power when you're on the job site.

Water Line to Platform

Features a 3/8-inch diameter, steel braided, pressure washer grade hose rated at 4,000 psi.

Outlets to Platform

110V GFI protected electrical outlets to the platform.

Easy-To-Use Controls

All Summit Series booms feature platform and ground controls that have an easy-to-understand display panel with logically positioned control buttons.

Highlights

- Automatic leveling in less than 30 seconds
- Best-in-class 12½ degree leveling capability
- Intuitive control system
- Multiple function speeds
- Hydraulic surge and parking brakes
- Integrated forklift pockets



SPECIFICATIONS

	2622 T	3632 T	4642 T	3522 A	4527 A	5533 A
Working height ¹	32 ft 6 in (10.1 m)	43 ft 6 in (13.4 m)	52 ft 4 in (16.1 m)	41 ft 9 in (12.9 m)	51 ft (15.7 m)	61 ft 3 in (18.8 m)
Maximum platform height ²	26 ft 6 in (8.1 m)	37 ft 6 in (11.4 m)	46 ft 4 in (14.1)	35 ft 9 in (10.9 m)	45 ft (13.7 m)	55 ft 3 in (16.8 m)
Horizontal outreach ³						
Maximum (from centerline)	22 ft (6.7 m)	32 ft (9.8 m)	41 ft 6 in (12.6 m)	19 ft (5.8 m)	27 ft (8.2 m)	33 ft 5 in (10.2 m)
Maximum (from edge of footpad)	17 ft 1 1/2 in (5.2 m)	27 ft (8.2 m)	35 ft 1 in (10.7 m)	17 ft 5 in (5.3 m)	21 ft (6.4 m)	27 ft 4 in (8.2 m)
Up and over height	N/A			19 ft (5.8 m)	20 ft 9 in (6.3 m)	23 ft 1 in (7 m)
Turntable rotation	700° non-continuous					
Load capacity ⁴	440 lb (200 kg)	500 lb (227 kg)	350 / 500 lb (159 / 227 kg)	500 lb (227 kg)		
A - Length - stowed	16 ft 5 1/2 in (5 m)	21 ft 11 in (6.7 m)	21 ft 8 in (6.6 m)	16 ft 3 in (4.9 m)	19 ft 6 in (5.9 m)	22 ft 11 in (7 m)
B - Width - stowed	5 ft 5 in (165 cm)					
C - Height - stowed	77 1/2 in (197 cm)	76 3/4 in (195 cm)	78 1/2 in (199 cm)	76 3/4 in (195 cm)		78 in (198 cm)
Platform						
D - Width	48 in (122 cm)					
E - Length	30 in (76 cm)					
F - Height	43 in (109 cm)					
Rotation / type ⁵	120° / manual					
Jib						
Length	N/A			4 ft 3 in (1.3 m)		
Vertical motion	N/A			150° (+70 / -80)		
Outrigger type	Hydraulic					
Leveling system	Auto Leveling					
Leveling capability	12 1/2°					
G - Outrigger footprint length	11 ft 3/4 in (3.4 m)	12 ft 4 in (3.8 m)	12 ft 11 in (3.9 m)	11 ft 3/4 in (3.4 m)	12 ft 4 in (3.8 m)	12 ft 11 in (3.9 m)
H - Outrigger footprint width	9 ft 10 1/2 in (3 m)	11 ft 4 in (3.5 m)	12 ft 9 in (3.9 m)	9 ft 10 1/2 in (3 m)	11 ft 4 in (3.5 m)	12 ft 9 in (3.9 m)
Footpad diameter	10 in (25 cm)	12 1/2 in (32 cm)		10 in (25 cm)	12 1/2 in (32 cm)	
Tow speed rating	65 mph					
Tongue weight ⁶						
Machine with no options	190 lb (86 kg)	200 lb (91 kg)	220 lb (100 kg)	245 lb (111 kg)	290 lb (132 kg)	335 lb (152 kg)
Machine with all options	240 lb (109 kg)	300 lb (136 kg)		400 lb (181 kg)		500 lb (227 kg)
Overrun brakes	Standard-Hydraulic, Option-Electric					
Parking brake	Standard-Mechanical					
Tire size	ST 205/75 R14C	ST 225/75 R15D		ST 205/75 R14C	ST 225/75 R15D	
Standard control system	24V DC					
Batteries	4 x 6V 245 amp-hr					
Charger	25 amp	40 amp		25 amp	40 amp	
Total weight						
Machine ⁶ with no options*	2,890 lb (1,311 kg)	4,400 lb (1,996 kg)	5,700 lb (2,585 kg)	3,400 lb (1,542 kg)	4,200 lb (1,905 kg)	4,800 lb (2,177 kg)

1. The metric equivalent of working height adds 2 m to the maximum platform height. U.S. adds 6 ft to the maximum platform height.

2. Maximum platform height when outriggers are fully extended on a level surface.

3. As is standard industry practice, this is measured from the edge of the platform plus 20 in (.5 m) arm reach.

4. Capacity may vary depending on options equipped on machine. Consult factory for details.

5. These are offered as optional equipment.

6. Weights will vary depending on options and/or market destination. Consult factory for details.

DIMENSIONS

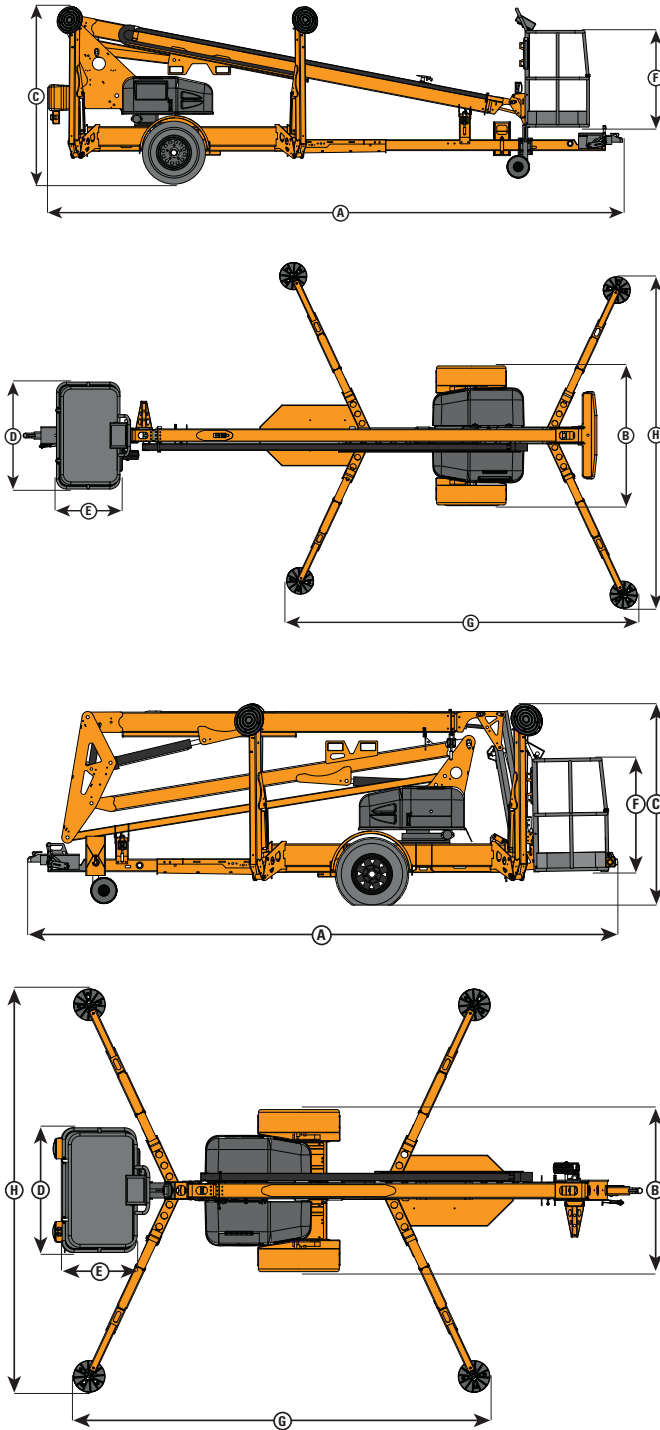

RANGE OF MOTION

2622T 3632T 4642T

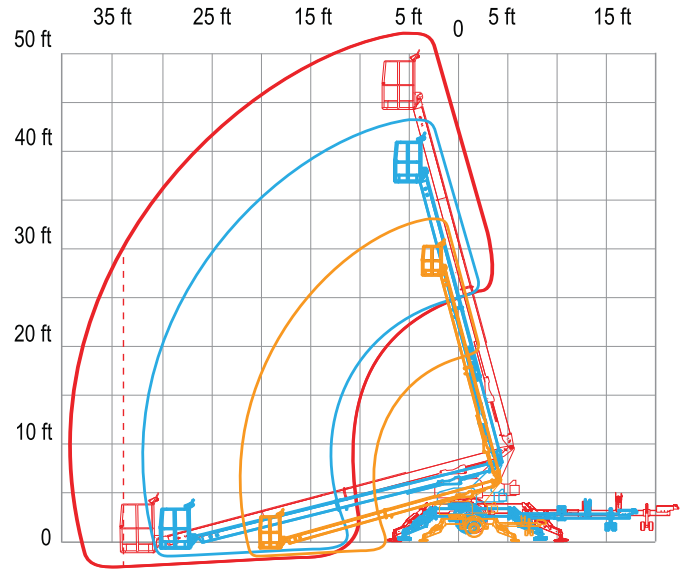

3522A 4527A 5533A

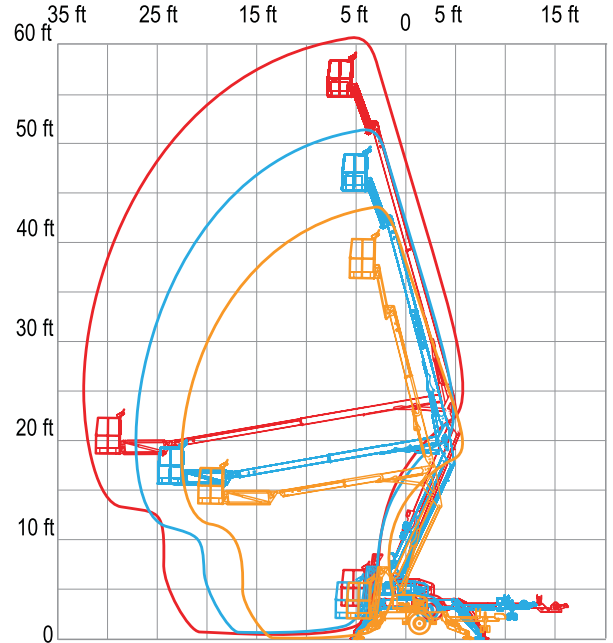

WARRANTY INFORMATION

HAULOTTE GROUP | BILJAX provides coverage on all products for one (1) full year, and covers all specified major structural components for five (5) full years. Due to continuous product improvements, we reserve the right to make specification and/or equipment changes without prior notification or obligation. Photographs and drawings contained herein are for illustrative purposes only. Refer to the appropriate Operator's Manual for instructions on the proper use of this equipment. Failure to follow the appropriate Operator's Manual instruction or to otherwise act irresponsibly, may result in serious injury or death. This machine meets or exceeds applicable OSHA Regulations, and complies with all ANSI standards as originally manufactured for intended applications. Market specific machine configurations meet or exceed applicable CSA standards.