



Outstanding performance, both inside and outside

- Suitable for all terrains allowing the operator to work without noise and fumes
- Tight turning radius allowing an excellent manoeuvrability in confined areas
- Foam filled and non-marking tires with rough terrain profile
- Ground clearance of 25 cm
- Load capacity up to 565 kg (C10 RTE)
- Driveable at full height
- Long working cycles

Robust, reliable, easy to maintain





COMPACT 10/12 RTE

ELECTRIC SCISSOR LIFTS

Compact 12 RTE

TECHNICAL DATA

Compact 10 RTE

Optimum 12 RTE

Working height	10.2 m	12.15 m
Platform height	8.2 m	10.15 m
Gradeability	25 %	25 %
Lift capacity	565 kg	450 kg
Platform length - outside	2.5 m	2.5 m
Platform length - extended	3.7 m	3.7 m
Length - extension	1.2 m	1.2 m
G Platform width - outside	1.54 m	1.54 m
Storage height	1.5 m	1.6 m
C Height - stowed	2.42 m	2.54 m
B Overall width	1.8 m	1.8 m
A Length	2.65 m	2.65 m
D Wheelbase	1.87 m	1.87 m
E Ground clearance	25 cm	25 cm
Ground clearance - Pothole guards deployed	N/A	0 cm
Drive speed	2 - 6 km/h	2 - 6 km/h
Driveable at full height up to	8.2 m	10.15 m
Tilt	3 °	3 °
Lift / lower speed	35 s / 40 s	43 s / 47 s
Turning radius - outside	3.73 m	3.73 m
Tyres - non marking	26x12-12	26x12-12
Batteries	48 V - 255 Amph (C5)	48 V - 255 Amph (C5)
Hydraulic system capacity	0 l	0 l
Weight	3380 kg	3800 kg

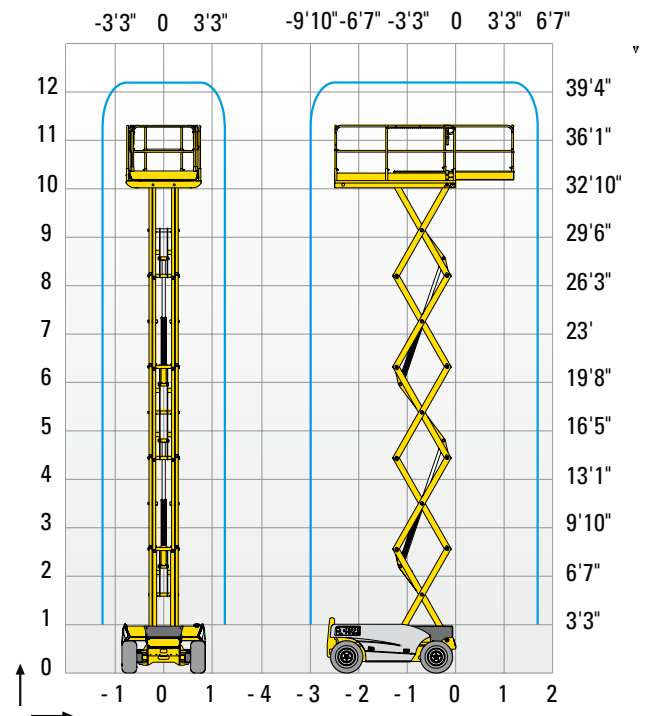

STANDARD EQUIPMENT

- Extended platform
- Proportional lift and drive
- Removable control box in platform
- Battery charge indicator
- Battery charger with automatic stop
- Lanyard attachment points
- 2 wheel-drive
- Free wheeling device
- Tilt controller
- Load Management System in the platform
- Manual platform lowering valve
- Hydraulic brakes
- Towing hooks
- Horn
- Hourmeter

OPTIONS AND ACCESSORIES

- Flashing light
- Travel alarm
- Power to platform
- Biodegradable hydraulic oil
- Outriggers (Increase machine weight by 240 kg)

