



SELF PROPELLED VERTICAL LIFT

Model • SJ12



2YEAR GOLD LEAF PROTECTION PROGRAM

Skyjack's new self propelled vertical mast lift provides a compact footprint, superior maneuverability and a working height of 5.7 m. When operating in tight workspaces, a high degree steer angle allows for superior functionality and flexibility by offering a zero inside turning radius. The SJ 12 features a 0.41 m traversing platform, providing increased access and the ability to reach over potential obstacles. A unique slide away platform provides easy access to components, when raised or in the stowed position.

- 3.7 m raised platform height
- 227 kg capacity
- 0.76 m overall width
- 1.37 m overall length
- 0.67 x 0.97 m platform size (Inside)
- Drivable at full height
- Variable speed, front two wheel hydraulic drive with zero inside turning radius
- 0.41 m traversing platform
- 30% gradeability
- Relay based control system with color coded and numbered wiring system

SELF PROPELLED VERTICAL LIFT

Specifications

SJ 12

A Work Height	5.7 m
B Raised Platform Height	3.7 m
C Lowered Platform Height	0.5 m
D Overall Width	0.8 m
E Overall Length	1.4 m
F Stowed Height	1.7 m
G Platform Width (Inside Dimension)	0.7 m
H Platform Length (Inside Dimension)	1.0 m
Ground Clearance (Stowed)	6.4 cm
Ground Clearance (Elevated)	1.9 cm
Weight	780 kg
Local Floor Load (with rated load)	790 kPa
Local Floor Load (no load)	583 kPa
Gradeability	30%
Turning Radius (Inside)	0
Turning Radius (Outside)	1.4 m
Drive Speed (Stowed)	4.8 km/h
Drive Speed (Raised)	0.8 km/h
Maximum Drive Height	Full Height
Capacity (Overall)	227 kg
Maximum # of Persons	2

STANDARD FEATURES

- Drivable at full height
- Variable speed, front two wheel hydraulic drive
- Zero inside turning radius
- Wet disc SAHR brakes
- Proportional controls
- 0.41 m traversing platform
- 24V DC power source
- Low voltage battery protection
- 30% gradeability
- Solid rubber, non-marking tyres
- Pothole protection system
- Wiring for AC outlet at platform
- 12.5 m/s wind rating
- Tilt alarm with drive & lift cut-out
- All motion audible alarm
- Lanyard attachment points
- Operator horn
- Lift rings/tie downs
- Half height spring hinged gate with kick plate
- Relay based control system
- Colour coded and numbered wiring system

OPTIONS‡

- Dual flashing lights
- Full height spring hinged gate
- Tool tray

‡ Capacities, and machine weights may differ when options are added.

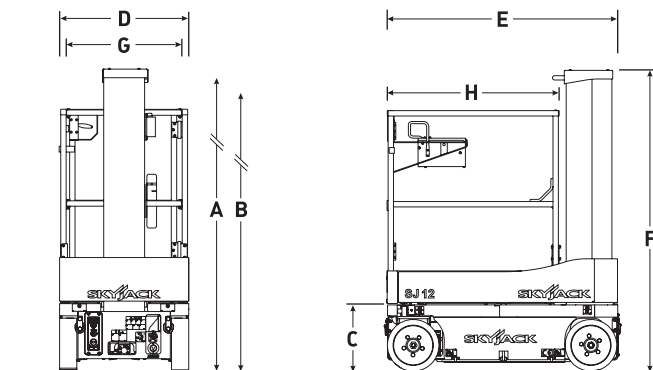

Skyjack Australia Pty Ltd

4 Coates Place
Wetherill Park
New South Wales, 2164
Tel: +61 (0) 2878 63200
Fax: +61 (0) 2878 63222
Email: jcranmer@skyjack.com

www.skyjack.com

This brochure is for illustrative purpose only and based on the latest information at the time of printing. Skyjack Inc. reserves the right to make changes at any time, without notice, to specifications, standard and optional equipment. Consult the Operating Maintenance and Parts Manuals for proper procedures. AS marked platforms are in conformance to Standard AS/NZS 1418.10:2011.