



## DC ELECTRIC SCISSOR LIFTS

Compact Series • SJIII 3215 • SJIII 3219



2 YEAR GOLD LEAF PROTECTION PROGRAM

The Compact Series DC Electric Scissor Lifts offer Skyjack's easy to service, low maintenance design in a compact and versatile package. Equipped with variable speed front wheel hydraulic drive, and 90° steering, both models in the Compact Series are capable of maneuvering in the smallest spaces. Featuring a 0.9 m roll out extension deck, these Compact Series models offer work heights up to 7.8 m and 30% gradeability.

- Up to 5.8 m raised platform height
- 227 kg capacity
- 0.81 m overall width
- 1.8 m overall length
- 0.66 x 1.6 m platform size (Inside)
- Drivable at full height
- Variable speed, front two wheel hydraulic drive with zero inside turning radius
- 0.9 m roll out extension deck
- 30% gradeability
- Relay based control system with color coded and numbered wiring system

# DC ELECTRIC SCISSOR LIFTS Compact Series

Specifications	SJIII 3215	SJIII 3219
<b>A Work Height</b>	6.5 m	7.8 m
<b>B Raised Platform Height</b>	4.5 m	5.8 m
<b>C Lowered Platform Height</b>	0.9 m	1.0 m
<b>D Overall Width</b>	0.8 m	0.8 m
<b>E Overall Length</b>	1.8 m	1.8 m
<b>F Stowed Height (Rails Up)</b>	2.0 m	2.1 m
<b>G Stowed Height (Rails Down)</b>	1.5 m	1.6 m
<b>H Platform Width (Inside Dimension)</b>	0.7 m	0.7 m
<b>I Platform Length (Inside Dimension)</b>	1.6 m	1.6 m
<b>Extension Deck (Roll Out)</b>	0.9 m	0.9 m
<b>Ground Clearance (Stowed)</b>	6.0 cm	6.0 cm
<b>Ground Clearance (raised)</b>	1.8 cm	1.8 cm
<b>Wheelbase</b>	1.4 m	1.4 m
<b>Weight</b>	1120 kg	1312 kg
<b>Gradeability</b>	30%	30%
<b>Turning Radius (Inside)</b>	0"	0"
<b>Turning Radius (Outside)</b>	1.7 m	1.7 m
<b>Lift Time (With Rated Load)</b>	22 sec	21 sec
<b>Drive Speed (Stowed)</b>	3.7 km/h	3.7 km/h
<b>Drive Speed (Raised)</b>	1.1 km/h	1.1 km/h
<b>Maximum Drive Height</b>	Full Height	Full Height
<b>Capacity (Overall)</b>	227 kg	227 kg
<b>Maximum # of Persons</b>	2	2

## STANDARD FEATURES

- Drivable at full height
- Variable speed, front two wheel hydraulic drive
- 90° steering (zero inside turning radius)
- Wet disc SAHR brakes
- Proportional controls for drive & lift functions
- 0.9 m roll out extension deck
- 24V DC power source
- Low voltage battery protection
- Up to 30% gradeability
- Solid rubber, non-marking tyres
- Pothole protection system
- Wiring for AC outlet on platform
- Tilt alarm with drive & lift cut-out
- All motion audible alarm
- Overload sensing system
- Lowering warning system
- Lanyard attachment points
- Operator horn
- Half height spring hinged gate
- Forklift pockets and tie down/lift lugs
- Analog control system
- Colour coded and numbered wiring system

## OPTIONS†

- Flashing light
- Dual flashing lights
- Shop airline to platform
- 250 Ah batteries
- Hinged railing system
- Full height spring hinged gate\*

\*not available with hinged railing system

‡ Capacities, and machine weights may differ when options are added

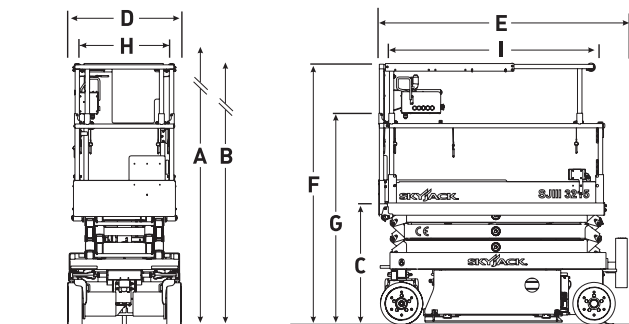

**Skyjack Australia Pty Ltd**  
 4 Coates Place  
 Wetherill Park  
 New South Wales, 2164  
 Tel: +61 (0) 2878 63200  
 Fax: +61 (0) 2878 63222  
 Email: jcranmer@skyjack.com

[www.skyjack.com](http://www.skyjack.com)

This brochure is for illustrative purpose only and based on the latest information at the time of printing. Skyjack Inc. reserves the right to make changes at any time, without notice, to specifications, standard and optional equipment. Consult the Operating Maintenance and Parts Manuals for proper procedures. AS marked platforms are in conformance to Standard AS/NZS 1418.10:2011.