

TURBOFARMER II

TF38.10TT-120

Merlo's all-new **Turbofarmer II telehandler** is built for maximum efficiency and power.

- ➔ **Fuel efficient** 120(HP) Tier 4 interim engine with CVTronic transmission
- ➔ 9.6m boom, 3.8 tonne load capacity and **20 tonne towing capability**
- ➔ **Load sensing hydraulics** and flow sharing pump
- ➔ Fully pressurised **1.1m wide cab**



SINCE 1964



MERLO
AUSTRALIA

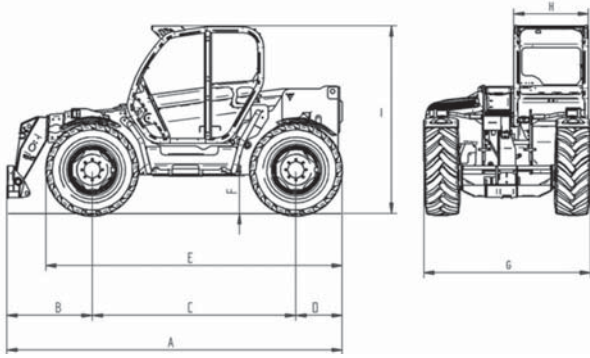

DIMENSIONS

A (mm)	4487
B (mm)	1100
C (mm)	2800
D (mm)	587
E (mm)	3976
F (mm)	440
G (mm)	2250
H (mm)	995
I (mm)	2465

PERFORMANCE

Unladen weight (kg)	8350
Maximum load capacity (kg)	3800
Maximum lift height (m)	9.6
Capacity at maximum height (kg)	3000
Maximum reach (m)	6.3
Capacity at maximum reach (kg)	700
Boom side-shift (mm)	±265
Frame levelling (%)	±10
Mechanical PTO (540/1000)	optional

Working Times

Ascent (sec)	6.6
Descent (sec)	5.5
Extension (sec)	5
Retraction (sec)	3.3

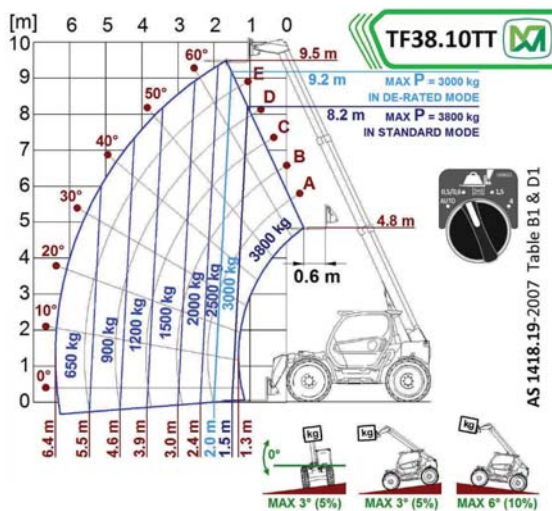

STANDARD SPECIFICATIONS

Engine

Turbo engine	Deutz Tier 4 Interim
Range/cylinders	3,6/4
Engine power (kW/HP)	90/122
Maximum speed (km/h)	40
Fuel tank capacity (l)	150

Transmission

Hydrostatic Merlo transmission	EPD
Speeds	2
Dual reverse shuttle system	✓
Pedal inching-control	✓
Permanent four-wheel drive	✓

Brakes

Automatic parking brake	✓
-------------------------	---

Tyres

Standard tyres	405/70-24
----------------	-----------

Cab

Air conditioned cabin	✓
Air suspension seat	✓
FOPS (ISO 3449) and ROPS (ISO 3471) cab	✓

Steering

All wheel steering	✓
--------------------	---

Instruments

Electromechanical joystick control	✓
Electronic joystick control	optional
Merlo Dynamic Load Control (M-CDC)	✓

Hydraulic System-Implement

Load-sensing hydraulic system (bar-l/min)	210-150
BSS Hydro-pneumatic boom suspension	✓
Hydraulic oil tank capacity (l)	110
Fan Drive Pump (l/min)	46
Auxiliary hydraulic service on boom	✓

Dimensions

Width (mm)	2250
Height (mm)	2460
Length (mm)	4490

Accessories & Attachments

Standard forks	✓
Fork extensions	optional
Digging bucket	optional
Re-handling bucket	optional
4 x 1 bucket	optional
Multipurpose bucket with grab	optional
Crane hook	optional
Reduced height crane jib	optional
Drum clamp	optional
Forks with slide protection	optional
Handler for single round bale	optional
Tac-lock attachment locking	✓
Two floating forks	✓



Merlo reserves the right to modify and update the contents of this document at any time. Information and technical data are as available at time of printing.

For current information on Merlo products please contact your Merlo dealer.
ABN 87116110751 **MER-TF38.10-2016**