

Dingli 
Australia

www.dingliaustralia.com.au



Rizer

S04-E

ELECTRIC SCISSOR LIFTS

Rizer

S04-E

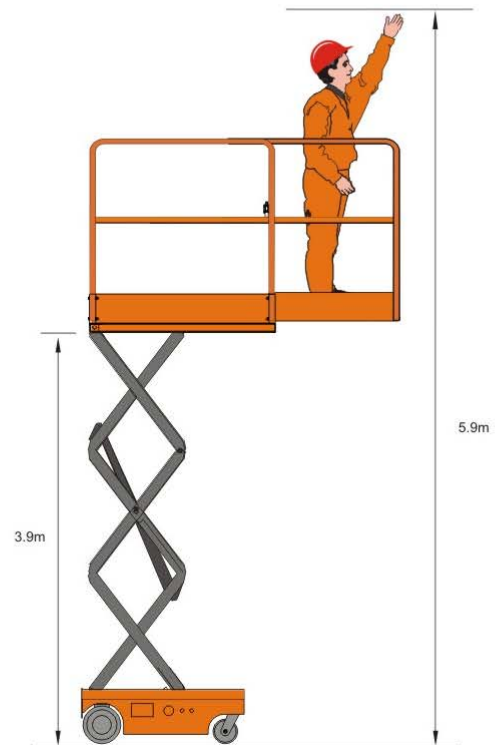
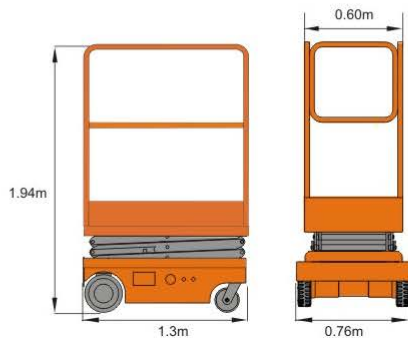

S.W.L	240kg/529lb
S.W.L on extension	100kg/220lb
Max. Occupants	1



Working height	5.90m/19ft4in
Platform floor height	3.90m/12ft9in



Overall length	1.30m/4ft3in
Overall width	0.76m/2ft6in
Overall height	1.94m/6ft4in
Platform size	1.30mx0.70m/4ft3inx2ft3in
Platform extension size	0.55m/1ft10in
Ground clearance	0.025m/1in
Wheelbase	1.03m/3ft4in
Turning radius	0



Drive motors	2x24V DC/0.3kw
Lifting motor	24V DC/0.8kw



Travel speed	
Stowed	4Km/h 2.5miles/h
Raised	0.5Km/h 0.3miles/h
Up/Down speed	32/21 sec
Wind Rated	0-12.5m/s



Batteries	2x12V/95Ah
Integrated charger	24V/10A



Gradeability	25%
Maximum working slope	1.5-2°



Drive wheels	φ 230x80mm
Front wheels	6in



Weight	590kg/1300lb
---------------	--------------

Standard Equipment

- Proportional Controls
- Self-lock Gate On Platform
- Extended Platform
- Drivable At Full Height
- Non-marking Tyres
- 2WD
- Automatic Brake System
- Emergency Lowering System
- Emergency Stop Buttons
- Cylinder Holding Valve
- Tilt Sensor With Alarm
- All Motion Alarm
- Horn
- Hour Meter
- Safety Brackets
- Forklift Pockets
- Charger Protection
- Flashing Beacon
- Folding Handrails
- Lockable Front Castors
- Entrance Ladder
- Overload Sensor With Alarm

Options

- AC Power To Platform

Please Note:-
All information contained in this publication was correct at time of printing but may be subject to change without notice.

