

**Dingli**   
**Australia**

[www.dingliaustralia.com.au](http://www.dingliaustralia.com.au)

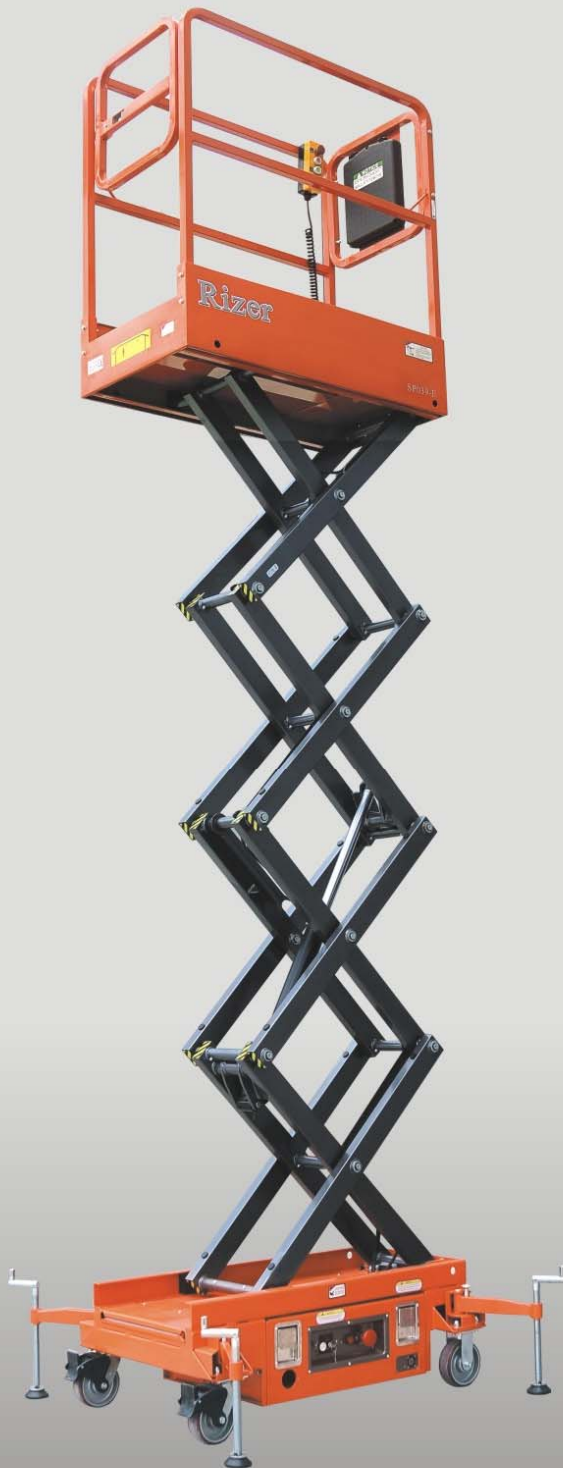

**Rizer**  

---

**SP039-E**

# MOBILE SCISSOR LIFTS

# Rizer

## SP039-E

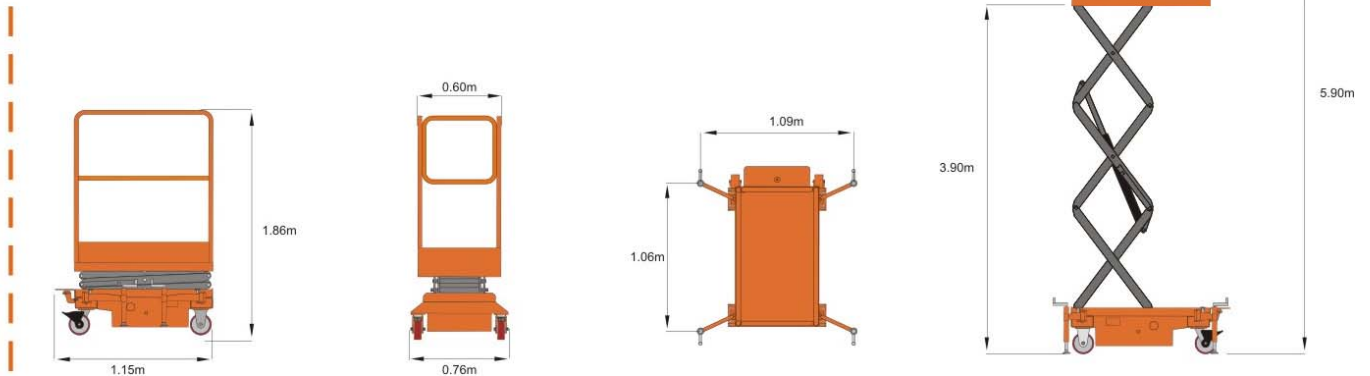

<b>S.W.L</b>	240kg/529lb
--------------	-------------



<b>Working height</b>	5.90m/19ft4in
<b>Platform floor height</b>	3.90m/12ft9in



<b>Overall length</b>	1.15m/3ft9in
<b>Overall width</b>	0.76m/2ft6in
<b>Overall height</b>	1.86m/5ft10in
<b>Platform size</b>	1.15mx0.60m/3ft9inx1ft11in
<b>Ground clearance</b>	0.06m/2in
<b>Wheelbase</b>	0.94m/2ft8in



<b>Lifting motor</b>	12V DC/0.8kw
----------------------	--------------



<b>Up/Down speed</b>	40/48 sec
----------------------	-----------



<b>Batteries</b>	12V/120Ah
<b>Integrated charger</b>	12V/12A



<b>Tyres</b>	0.15m/6in
--------------	-----------



<b>Weight</b>	420kg/925lb
---------------	-------------

### Standard Equipment

- Battery Charge Indicator
- Levelling Indicator
- Safety Brackets
- Emergency Stop Button
- Levelling Outrigger Device
- Dual Locking Castors
- Forklift Pockets
- Overload Restriction

**Please Note:-**  
All information contained in this publication was correct at time of printing but may be subject to change without notice.

