



SJ30 ARJE

ELECTRIC ARTICULATING BOOM

STANDARD FEATURES

- Rotating jib
- Direct AC electric drive
- Dual spring applied, electromagnetically released brakes
- Regenerative braking
- Speed and angle sensing traction control
- 48V 305 Ah battery pack
- 12.5 m/s wind rating
- DC Powered emergency lowering
- Secondary guarding electrical (SGE)
- Drivable at full height
- 355° Non-continuous turret rotation
- 35% gradeability
- Swing out battery trays
- Swing out cowlings
- Modular platform railing system
- Rear-entry sliding mid rail
- Wiring for AC outlet on platform
- Direction sensing drive and steer controls
- Proportional drive and boom controls
- Function speed selector
- Relay based control system
- Colour coded and numbered wiring
- Hour meter
- Operator horn
- Tie down/lifting lugs
- 22 x 7 x 12 solid rubber, non-marking tyres

ACCESSORIES AND OPTIONS

- Pipe rack
- Tool caddy
- Platform work lights
- Flashing light
- All motion audible alarm
- 1/2" Airline to platform
- Control box cover
- 360 Ah batteries
- 330 Ah AGM batteries
- Rear gate
- Bio oil

Preliminary specifications at time of printing. Consult your local area sales representative for details.

† Standard lead times may be increased when optional equipment is added, consult factory.

‡ Capacities, and machine weights may differ when options are added.

SJ30 ARJE ELECTRIC ARTICULATING BOOM

Dimensions	SJ30 ARJE
Work Height	11.00 m
Platform Height	9.00 m
Horizontal Reach	6.25 m
Up and Over Height	3.99 m
A Platform Size	0.76 m x 1.17 m
B Stowed Width	1.19 m
C Tailswing	0
D Stowed Height	2.01 m
E Transport Height	2.54 m
F Stowed Length	5.44 m
G Transport Length	4.09 m
H Wheelbase	1.65 m
Ground Clearance	10.16 cm

Specifications	SJ30 ARJE
Turret Rotation	355° NC
Platform Rotation	180°
Jib Length	1.25 m
Jib Range of Motion - Horizontal	180°
Jib Range of Motion - Vertical	142° (+77°/-65°)
Weight	5,750 kg
Gradeability - Counterweight Facing Up	35%
Gradeability - Counterweight Facing Down	25%
Turning Radius (Inside)	1.52 m
Turning Radius (Outside)	3.23 m
Drive Speed (Stowed)	4.8 km/h
Drive Speed (Elevated/Extended)	0.64 km/h
Capacity	227 kg
Local Floor Load (With Rated Load)	1,505 kPa
Overall Floor Load (With Rated Load)	22 kPa
Maximum # of Persons (indoors/outdoors)	2/1
Wind Rating	12.5 m/s
Tyre Type	Solid, N/M
Tyre Size	22 x 7 x 12

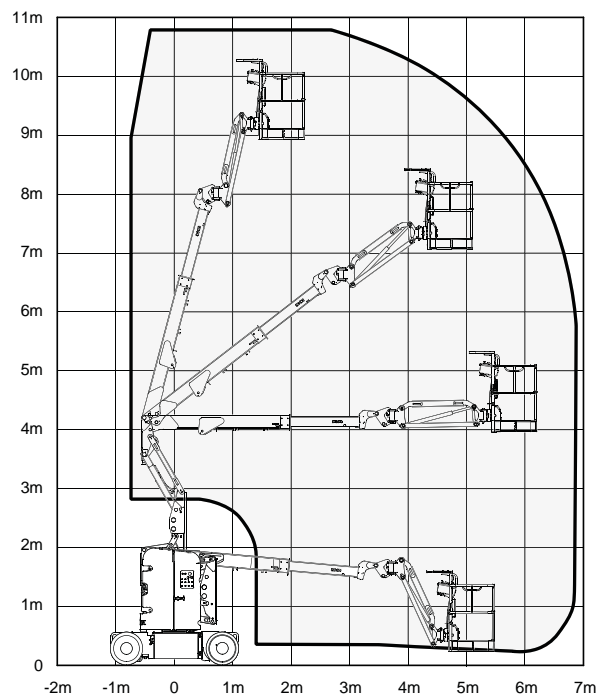
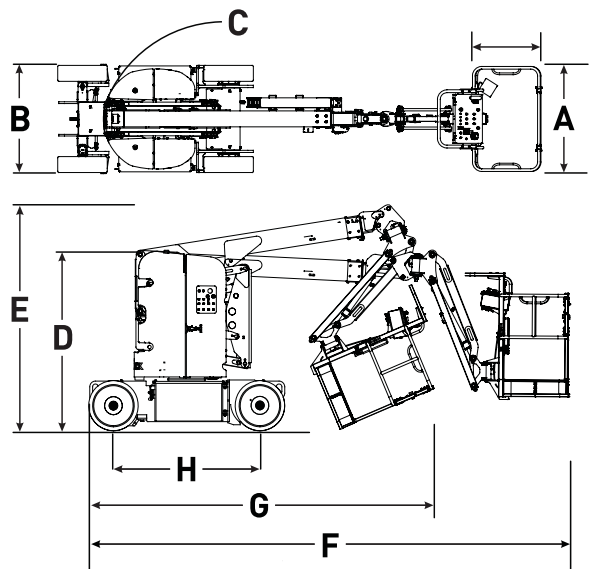

Skyjack UK
 Unit 1, Maes-y-Clawdd
 Maesbury Road Industrial Estate
 Oswestry, Shropshire, SY10 8NN
 Tel: +44 (0) 1691 676235
 Fax: +44 (0) 1691 676239
 Email: info@skyjackeurope.co.uk

Skyjack France
 74 Rue Sibert
 F-42400 Saint-Chamond
 France
 Tel. +33 (0) 4 78 73 53 32
 Fax. +33 (0) 4 78 56 52 42

Skyjack Germany
 Därmannsbusch 2a
 D-58456 Witten
 Germany
 Tel: +49 (0) 2302 20 26 909
 Fax: +49 (0) 2302 20 25 671

Skyjack AB Sweden
 Agnesbergsvägen 28
 424 38 Agnesberg
 Sweden
 Tel: +46 (0) 31 21 22 45
 Fax: +46 (0) 31 787 65 10

www.skyjack.com

This brochure is for illustrative purpose only and based on the latest information at the time of printing. Skyjack Inc. reserves the right to make changes at any time, without notice, to specifications, standard and optional equipment. Consult the Operating Maintenance and Parts Manuals for proper procedures. CE marked work platforms are in conformance to Machinery Directive 2006/42/EC.