



Dingli
Australia

www.dingliaustralia.com.au



Gofer

TT045-IPE

ELECTRIC AERIAL ORDER PICKER

Gofer

TT045-IPE

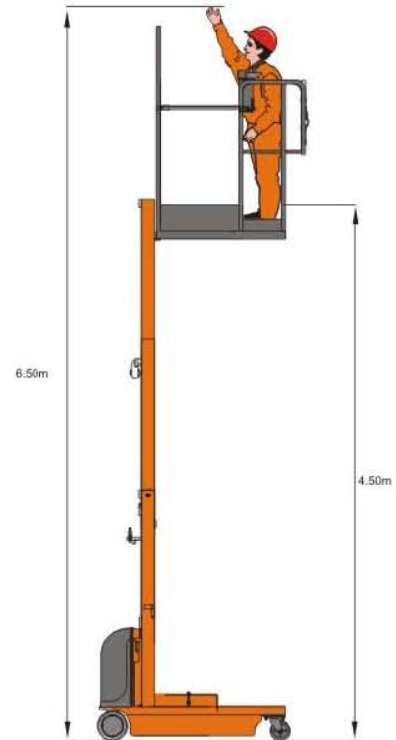
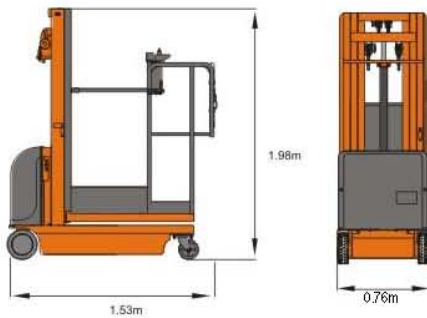

| | | |
|--|--------------|-------------|
| | S.W.L | 300kg/660lb |
|--|--------------|-------------|

| | | |
|--|------------------------------|---------------|
| | Working height | 6.50m/21ft4in |
| | Platform floor height | 4.50m/14ft9in |

| | | |
|--|-------------------------|----------------------------------|
| | Overall length | 1.53m/5ft2in |
| | Overall width | 0.76m/2ft6in |
| | Overall height | 1.98m/6ft6in |
| | Platform size | 0.90m x 0.64m / 2ft11in x 2ft1in |
| | Ground clearance | 0.05m/2in |
| | Wheelbase | 1.24m/4ft0.8in |
| | Turning radius | 0 |

| | | |
|--|----------------------|----------------|
| | Drive motors | 2x24V DC/0.4kw |
| | Lifting motor | 24V DC/2kw |

| | | |
|--|----------------------|---------------------|
| | Travel speed | |
| | Stowed | 4Km/h 2.5miles/h |
| | Raised | 1.1km/h 0.68miles/h |
| | Up/Down speed | 23/25 sec |

| | | |
|--|---------------------------|-------------|
| | Batteries | 2x12V/120Ah |
| | Integrated charger | 24V/10A |

| | | |
|--|---------------------|-----|
| | Gradeability | 25% |
|--|---------------------|-----|

| | | |
|--|--------------|------------|
| | Tyres | |
| | Drive motors | φ 230x80mm |
| | Front wheels | 0.15m/6in |

| | | |
|--|---------------|--------------|
| | Weight | 675kg/1488lb |
|--|---------------|--------------|

Standard Equipment

- Can Bus Technology
- Proportional Controls
- Battery Charge Indicator
- Forklift Pockets
- Safety Brackets
- Low Voltage Alarm
- Emergency Down Button
- Charger Protection
- Controller Temperature Protection
- 2WD
- Overload Restriction

